



STATYBOS PRODUKCIJOS  
SERTIFIKAVIMO CENTRAS

Linkmenų str. 28, LT-08217 Vilnius, Lithuania  
Tel: +370 5 2728077, fax: +370 5 2728075  
centras@spsc.lt, www.spsc.lt



Member of



www.eota.eu

## European Technical Assessment

**ETA-15/0446**  
of 2015-08-06

### General Part

**Technical Assessment Body issuing the European Technical Assessment**

**VĮ Statybos produkcijos sertifikavimo centras**

**Trade name of the construction product:**

**Angle brackets, types MK, MKN  
Angle brackets with a rib, types MKS, MKNS**

**Product family to which the above construction product belongs:**

**EC PAC 13: Three-dimensional nailing plate  
(Angle brackets for timber to timber connections)**

**Manufacturer:**

**UAB "Ardetas"  
Žirmūnų g. 46-40, LT-09227 Vilnius  
Lithuania  
[www.ardetas.lt](http://www.ardetas.lt)**

**Manufacturing plant:**

**UAB "Ardetas"  
Arnionių g. 60, LT-18170 Pabradė,  
Švenčionių district, Lithuania  
[www.ardetas.lt](http://www.ardetas.lt)**

**This European Technical Assessment contains:**

**89 pages including 4 Annexes which form an integral part of this assessment.**

**Annex – Control plan contain confidential information and is not included in the European Technical Assessment when that assessment is publicly disseminated**

**This European Technical Assessment is issued in accordance with regulation (EU) No 305/2011, on the basis of**

**ETAG 015, edition November 2012, used as European Assessment Document (EAD).**

Translations of this European Technical Assessment in other languages shall fully correspond to the original issued document.

Communication of this European Technical Assessment, including transmission by electronic means, shall be in full (excepted the confidential Annex referred to above). However, partial reproduction may be made, with the written consent of the issuing Technical Assessment Body. Any partial reproduction has to be identified as such.

The European Technical Assessment is issued by the assessment body in its official Lithuanian language. This version corresponds fully to the version circulated within EOTA in English language. Translations into other languages have to be designated as such.

This European Technical Assessment is not to be transferred to manufacturers or agents of manufacturer other than those indicated on page 1; or manufacturing plants other than those laid down in the context of this European Technical Assessment without notification to SPSC.

## Specific Parts

### 1. Technical description of the product

Angle brackets given in Table 1 are one-piece non-welded face fixed angle brackets to be used in timber to timber connections. They are connected to the timber elements by ringed shank nails.

**Table 1.** Angle brackets Angle bracket type and overall dimensions

Angle bracket type and overall dimensions (Isosceles Angle bracket)					
MK	60 × 60 × 40 × 2,0	MK	50 × 50 × 35 × 2,0	MKS	50 × 50 × 35 × 2,0
MK	80 × 80 × 40 × 2,0	MK	50 × 50 × 35 × 2,5	MKS	50 × 50 × 35 × 2,5
MK	60 × 60 × 60 × 2,0	MK	50 × 50 × 50 × 2,0	MKS	50 × 50 × 50 × 2,0
MK	80 × 80 × 60 × 2,0	MK	60 × 60 × 50 × 2,0	MKS	50 × 50 × 50 × 2,5
MK	100 × 100 × 60 × 2,0	MK	60 × 60 × 50 × 2,5	MKS	60 × 60 × 50 × 2,0
MK	60 × 60 × 80 × 2,0	MK	70 × 70 × 55 × 2,0	MKS	60 × 60 × 50 × 2,5
MK	80 × 80 × 80 × 2,0	MK	70 × 70 × 55 × 2,5	MKS	70 × 70 × 55 × 2,0
MK	100 × 100 × 80 × 2,0	MK	90 × 90 × 40 × 2,0	MKS	70 × 70 × 55 × 2,5
MK	60 × 60 × 100 × 2,0	MK	90 × 90 × 40 × 2,5	MKS	70 × 70 × 65 × 2,0
MK	80 × 80 × 100 × 2,0	MK	90 × 90 × 40 × 3,0	MKS	90 × 90 × 50 × 2,0
MK	100 × 100 × 100 × 2,0	MK	90 × 90 × 65 × 2,0	MKS	90 × 90 × 50 × 2,5
MK	60 × 60 × 40 × 2,5	MK	90 × 90 × 65 × 2,5	MKS	90 × 90 × 65 × 2,0
MK	80 × 80 × 40 × 2,5	MK	100 × 100 × 90 × 2,0	MKS	90 × 90 × 65 × 2,5
MK	60 × 60 × 60 × 2,5	MK	100 × 100 × 90 × 2,5	MKS	100 × 100 × 90 × 2,0
MK	80 × 80 × 60 × 2,5	MK	105 × 105 × 90 × 3,0	MKS	100 × 100 × 90 × 2,5
MK	100 × 100 × 60 × 2,5			MKS	105 × 105 × 90 × 3,0
MK	60 × 60 × 80 × 2,5				
MK	80 × 80 × 80 × 2,5				
MK	100 × 100 × 80 × 2,5				
MK	60 × 60 × 100 × 2,5				
MK	80 × 80 × 100 × 2,5				
MK	100 × 100 × 100 × 2,5				
Angle bracket type and overall dimensions (non - isosceles Angle bracket)					
MKNS	90 × 50 × 50 × 2,0	MKN	120 × 40 × 40 × 2,0	MKN	90 × 50 × 50 × 2,0
MKNS	90 × 50 × 50 × 2,5	MKN	80 × 40 × 40 × 2,0	MKN	90 × 50 × 50 × 2,5
MKNS	150 × 90 × 65 × 2,0	MKN	120 × 40 × 60 × 2,0	MKN	95 × 45 × 40 × 2,5
MKNS	150 × 90 × 65 × 2,5	MKN	80 × 40 × 60 × 2,0	MKN	135 × 45 × 40 × 2,0
MKNS	150 × 100 × 90 × 2,0	MKN	100 × 60 × 60 × 2,0	MKN	135 × 45 × 40 × 2,5
MKNS	150 × 100 × 90 × 2,5	MKN	200 × 40 × 40 × 2,0		

The angle brackets are made from pre-galvanized steel DX51D+Z275 according to standard EN 10346:2009<sup>1</sup> with minimum yield strength  $R_e$  of 250 MPa, minimum tensile strength  $R_m$  of 330 MPa and minimum elongation  $A_{80}$  of 22 %. Dimensions, hole positions are shown in the Annex C, typical installations are shown in Annex B. Angle brackets are made from steel with normal thickness tolerances according to EN 10143:2006<sup>2</sup>. Product details are shown in Annex A.

## 2. Specifications of the intended use in accordance with the applicable EAD

Intended use of the angle brackets are the connections between beams of load bearing timber structures, where the requirements for mechanical resistance, stability and safety in use in the sense of the Basic Requirements 1 and 4 of Regulation (EU) No 305/2011 of the European Parliament and of the Council of 9 March 2011 shall be fulfilled.

The static and kinematic behaviour of the timber members or the supports shall be as described in Annex B.

The wood members may be of solid timber or glued laminated timber with a characteristic density from 290 kg/m<sup>3</sup> to 420 kg/m<sup>3</sup>. This requirement for material of the wood members may be fulfilled by using the following materials:

- structural solid timber classified to C14-C40 strength class according to EN 338:2010<sup>3</sup> and EN 14081-1:2005+A1:2011<sup>4</sup>;

- glulam classified to GL24-GL36 according to EN 14080:2013<sup>5</sup>.

For joints shall be used threaded nails according to EN 14592:2008+A1:2012<sup>6</sup> with diameter 4,0 mm. Another type of threaded nails may be used with values of axial characteristic load-carrying capacity per nail not less than stated in declaration of performance CE 300147-A3 of the nails producer GBO Fastening systems AB, Bruksvägen 2, SE 590 93 Gunnebo, Sweden, and with the tensile capacity of the wire for the nails equal to or greater than 650 N/mm<sup>2</sup>.

Annex B states the load-carrying capacities of the angle brackets connections for a characteristic density of 350 kg/m<sup>3</sup> of solid timber or glulam. For solid timber or glulam with a lower characteristic density than 350 kg/m<sup>3</sup> the load-carrying capacities of the nailed connection shall be modified by the  $k_{dens}$  factor:

$$k_{dens} = \sqrt{\frac{\rho_k}{350}}$$

where:

$\rho_k$  is the characteristic density of timber used in the connection.

The design of the connections shall be in accordance with Eurocode 5<sup>7</sup> or according to similar national regulations for design. The wood members shall have the thickness which is larger than the penetration depth of the nails into the members.

---

<sup>1</sup> EN 10346:2009 Continuously hot-dip coated steel flat products - Technical delivery conditions.

<sup>2</sup> EN 10143:2006 Continuously hot-dip coated steel sheet and strip - Tolerances on dimensions and shape.

<sup>3</sup> EN 338:2009 Structural timber - Strength classes.

<sup>4</sup> EN 14081-1:2005+A1:2011 Timber structures - Strength graded structural timber with rectangular cross section - Part 1: General requirements.

<sup>5</sup> EN 14080:2013 Timber structures - Glued laminated timber and glued solid timber - Requirements

<sup>6</sup> EN 14592:2008+A1:2012 Timber structures - Dowel-type fasteners – Requirements

<sup>7</sup> EN 1995-1-1 Eurocode 5: Design of timber structures - Part 1-1: General - Common rules and rules for buildings.

The angle brackets are primarily intended for use in timber structures subject to the dry, internal conditions defined by service class 1 and 2 of Eurocode 5 and for connections subject to static or quasi-static loading. The angle brackets can also be used in outdoor structures, defined by service class 3, when a corrosion protection in accordance with Eurocode 5 is applied, or when stainless steel with similar or better characteristic yield, ultimate strength and ductility is employed.

They are not intended for used in areas where they might support seismic actions.

The provisions made in this European Technical Assessment are based on an assumed intended working life of the three-dimensional nailing plates of 50 years. The indications given on the working life cannot be interpreted as a guarantee given by the producer, but are to be regarded only as a means for choosing the right products in relation to the expected economically reasonable working life of the works.

## **2.1 Installation**

### **2.1.1 Joints**

A connector (three dimensional nailing plates – angle brackets) is deemed fit for its intended use provided:

- joints are designed in accordance with Eurocode 5 or an appropriate national regulations for timber constructions design under the responsibility of an engineer experienced in timber structures;

- the structural members to which the angle brackets are fixed shall be restrained against rotation;

- the structural members of solid timber shall be of strength class C14 or better;

- the structural members of glulam shall be of strength class GL24 or better;

- the structural members shall be free from wane under the angle brackets;

- the tensile strength perpendicular to the grain capacity of the timber member to be used in conjunction with the angle brackets is to be checked by the designer of the structure to ensure that it is not less than the angle brackets capacity and, if necessary, the angle brackets capacity shall be reduced accordingly;

- the gap between the timber members does not exceed 3 mm;

- there are no specific requirements relating to preparation of the timber members.

### **2.1.2 Criteria**

The fitness for use of the joint can be assumed if the connector is installed correctly in accordance with the following requirements:

- installation is carried out by personnel under the direction of supervisors, which are appropriately qualified for this work;

- installation is in accordance with the manufacturer's specifications and drawings prepared for that purpose, and the appropriate tools are used;

- the specified fasteners are used.

### 2.1.3 Responsibility of the manufacturer

It is the responsibility of the manufacturer to ensure that the information on the specific conditions given in sections 8, 9 and 10 of this European technical assessment, is given to those concerned. This information may be made by replicating the respective parts of this European Technical Assessment. In addition, all installation data shall be shown clearly on the package and / or on an instruction sheet, preferably using illustration(s).

The minimum information required is:

- fastener specification;
- requirements for timber members;
- identification of the manufacturing batch.

All data shall be presented in a clear and explicit form.

## **2.2 Recommendations**

### 2.2.1 Recommendations on packaging, transport and storage

The angle brackets are packed in boxes bearing the manufacturer's name, product type, dimensions, quantity, date of fabrication and batch reference details.

In relation to transportation and storage, the connectors should be treated as conventional metallic building products.

### 2.2.2 Recommendations on use, maintenance and repair

The assessment of the fitness for use is based on the assumption that maintenance is not required during the assumed intended working life.

### 3. Performance of the product and references to the methods used for its assessment:

ETAG paragraph	Characteristic	Assessment of characteristic
<b>3.1 Mechanical resistance and stability</b>		
2.4.1	Characteristic load-carrying capacity	see Annex B
2.4.1	Stiffness	No performance assessed
2.4.1	Ductility in cyclic testing	No performance assessed
<b>3.2 Safety in case of fire</b>		
2.4.2.1	Reaction to fire	The angle brackets are made from steel classified as Euroclass A1 in accordance with EN 13501-1:2007+A1:2009 <sup>8</sup> and EC decision 96/603/EC <sup>9</sup> , amended by EC Decision 2000/605/EC <sup>10</sup>
2.4.2.2	Resistance to fire	No performance assessed
<b>3.3 Hygiene, health and the environment</b>		
2.4.3	Release of dangerous substances	No dangerous materials <sup>1)</sup>
<b>3.4 General aspects relating to fitness for use (serviceability)</b>		
2.4.7	Durability	
2.4.7.2	Resistance to corrosion and deterioration	The angle brackets have been assessed as having satisfactory durability and serviceability when used in timber structures using the timber species described in Eurocode 5 and subject to the conditions defined by service class 1 and 2
2.4.8	Dimensional stability	Tests are carried out during the assessment for mechanical resistance and stability

<sup>1)</sup> Based on the declaration of the manufacturer and in accordance with TR 034<sup>11</sup> the three dimensional nailing plates do not contain harmful or dangerous substances as defined in the EU database.

In accordance with the Regulation (EC) No 1907/2006 of the European Parliament and the Council of 18 December 2006<sup>12</sup> and [http://ec.europa.eu/growth/sectors/chemicals/reach/index\\_en.htm](http://ec.europa.eu/growth/sectors/chemicals/reach/index_en.htm), the product does not contain/release dangerous substances.

In addition to the specific clauses relating to dangerous substances contained in this European Technical Assessment, there may be other requirements applicable to the products falling within its scope (e.g. transposed European legislation and national laws, regulations and administrative provisions). In order to meet the provisions of the Regulation (EU) No 305/2011, these requirements need also to be complied with, when and where they apply

<sup>8</sup> EN 13501-1:2007+A1:2009 Fire classification of construction products and building elements - Part 1: Classification using data from reaction to fire tests.

<sup>9</sup> OJ L 267, 19.10.1996, p. 23.

<sup>10</sup> OJ L 258, 12.10.2000, p. 36

<sup>11</sup> General ER 3 Checklist for ETAGs/CUPAs/ETAs-Content and/or release of dangerous substances in products/kits, Edition March 2012

<sup>12</sup> OJ L 396, 30.12.2006, p. 1

### 3.1 Mechanical resistance and stability

The assessment of fitness for the intended use has been made in accordance with ETAG 015. The characteristic load-carrying capacities of the products are given in Annex B, which have been derived by calculation.

The characteristic load-carrying capacities are based on the characteristic values of the nail connections, timber components and steel plates. The calculations were performed according to Eurocode 5.

According to EN 1990<sup>13</sup> for structures or structural members that comprise more than one material acting in association, partial factors of all used materials shall be computed to obtain design values.

To obtain design values the capacities have to be divided by different partial factors of the material properties, the nail connection and the timber components in addition multiplied with the coefficient  $k_{mod}$ .

$$F_{1,d} = \frac{F_{1,k} \cdot k_{mod}}{\gamma_M}$$

where:

$F_{1,k}$  is the characteristic load-carrying capacity;

$k_{mod}$  is the modification factor depending on service class and load-duration classes, see EN 1995-1-1<sup>14</sup>, § 3.1.3;

$\gamma_M$  is the partial factor for a material property, according EN 1995-1-1, § 2.4.1.

The characteristic load-carrying capacities in the direction F is presented in the Annex B. These values are based on the assumption that there is a maximum gap of 3 mm between the timber members (see Annex B, Figure B.1-B.4), the members are laterally restrained and wane is not present in the timber at the joint. Minimum spacings and edge and end distances for nails shall be according to Eurocode 5. The number and position of nails are shown in Annex D.

The characteristic capacities of the angle brackets should be used for design in accordance with Eurocode 5 or a similar national regulations for timber structures design.

In the calculations are used threaded nails of 4,0 mm diameter, according EN 14592:2008+A1:2012. Nails manufacturer - GBO Fastening systems AB, Bruksvägen 2, SE 590 93 Gunnebo, Sweden, declaration of performance CE 300147-A3.

The characteristic axial load-carrying withdrawal capacity of a nails is taken according nails manufacturer declaration of performance CE 300147-A3. The characteristic lateral load-carrying capacity of nails calculated from the formulas of Eurocode 5 as for thin steel plate, see EN 1995-1-1, expression (8.9).

No performance has been determined in relation to ductility of a joint under cyclic testing. The contribution to the performance of structures in seismic zones, therefore, has not been assessed.

No performance has been determined in relation to the joint's stiffness properties - to be used for the analysis of the serviceability limit state.

---

13 EN 1990 Eurocode - Basis of structural design

14 EN 1995-1-1 Eurocode 5: Design of timber structures - Part 1-1: General - Common rules and rules for buildings.



### **3.2 Safety in case of fire**

Performance in relation to fire resistance would be determined for the complete structural element with any associated finishes, therefore there are no relevant aspects of performance to this Basic Requirement for the connectors.

### **3.3 Hygiene, health and the environment**

Based on the declaration of the manufacturer and in accordance with TR 034, dated March 2012, the three dimensional nailing plates do not contain harmful or dangerous substances as defined in the EU database.

### **3.4 General aspects relating to fitness for use (durability and serviceability)**

#### **3.4.1 Durability**

The angle brackets have been assessed as having satisfactory durability and serviceability when used in timber structures with the timber species (including timbers preserved with organic solvent, boron diffusion and related preservatives) described in Eurocode 5 and subject to the dry, internal conditions defined by service classes 1 and 2 according Eurocode 5:

- service class 1 – is characterised by a moisture content in the materials corresponding to a temperature of 20°C and the relative humidity of the surrounding air only exceeding 65 % for a few weeks per year;
- service class 2 - characterised by a moisture content in the materials corresponding to a temperature of 20°C and the relative humidity of the surrounding air only exceeding 85 % for a few weeks per year.

In accordance with ETAG 015 the angle brackets are made from hot-dip zinc coating steel DX51D+Z275 according to EN 10346:2009 with a minimum yield strength  $R_e$  of 250 MPa, a minimum tensile strength  $R_m$  of 330 MPa and a minimum elongation  $A_{80}$  of 22 %.

#### **3.4.2 Dimensional stability**

Additional tests are not required for this property as it is covered during the assessment.

#### **4. Assessment and verification of constancy of performance (AVPC) system applied, with reference to its legal base**

According to the decision 97/638/EC<sup>15</sup> of the European Commission, the system of assessment and verification of constancy of performance applied to this product shall be as laid down in the Commission delegated regulation (EU) No 568/2014<sup>16</sup> amending Annex V to Regulation (EU) No 305/2011<sup>17</sup> of the European Parliament and of the Council, referred to as System 2+.

#### **5. Technical details necessary for the implementation of the AVCP system, as provided for in the applicable EAD**

All the necessary technical details for the implementation of the AVCP system are laid down in the Control Plan deposited with the Statybos produkcijos sertifikavimo centras (SPSC), with which the factory production control shall be in accordance.

**Issued in Vilnius on 2015-08-06**  
**By State Enterprise Statybos produkcijos sertifikavimo centras (SPSC)**

**Director**  
**Robertas Encius**

---

<sup>15</sup> Commission Decision 97/638/EC of 19 September 1997 on the procedure for attesting the conformity of construction products pursuant to Article 20(2) of Council Directive 89/106/EEC as regards fasteners for structural timber (OJ L 268, 1.10.1997, p. 36).

<sup>16</sup> Commission delegated regulation (EU) No 568/2014 of 18 February 2014 amending Annex V to Regulation (EU) No 305/2011 of the European Parliament and of the Council as regards the assessment and verification of constancy of performance of construction products (OJ L 157, 27.05.2014, p. 76).

<sup>17</sup> Regulation (EU) No 305/2011 of the European Parliament and of the Council of 9 March 2011 laying down harmonised conditions for the marketing of construction products and repealing Council Directive 89/106/EEC (OJ L 88, 4.04.2011, p. 5).

## ANNEX A

### Product details

**Table A.1.** Steel for angle brackets specification

Angle bracket type		Steel thickness (mm)	Steel and coating specification <sup>1)</sup>
Isosceles Angle brackets			
MK	60 × 60 × 40 × 2,0	2,0	EN 10346 - DX51D + Z275
MK	80 × 80 × 40 × 2,0	2,0	EN 10346 - DX51D + Z275
MK	60 × 60 × 60 × 2,0	2,0	EN 10346 - DX51D + Z275
MK	80 × 80 × 60 × 2,0	2,0	EN 10346 - DX51D + Z275
MK	100 × 100 × 60 × 2,0	2,0	EN 10346 - DX51D + Z275
MK	60 × 60 × 80 × 2,0	2,0	EN 10346 - DX51D + Z275
MK	80 × 80 × 80 × 2,0	2,0	EN 10346 - DX51D + Z275
MK	100 × 100 × 80 × 2,0	2,0	EN 10346 - DX51D + Z275
MK	60 × 60 × 100 × 2,0	2,0	EN 10346 - DX51D + Z275
MK	80 × 80 × 100 × 2,0	2,0	EN 10346 - DX51D + Z275
MK	100 × 100 × 100 × 2,0	2,0	EN 10346 - DX51D + Z275
MK	60 × 60 × 40 × 2,5	2,5	EN 10346 - DX51D + Z275
MK	80 × 80 × 40 × 2,5	2,5	EN 10346 - DX51D + Z275
MK	60 × 60 × 60 × 2,5	2,5	EN 10346 - DX51D + Z275
MK	80 × 80 × 60 × 2,5	2,5	EN 10346 - DX51D + Z275
MK	100 × 100 × 60 × 2,5	2,5	EN 10346 - DX51D + Z275
MK	60 × 60 × 80 × 2,5	2,5	EN 10346 - DX51D + Z275
MK	80 × 80 × 80 × 2,5	2,5	EN 10346 - DX51D + Z275
MK	100 × 100 × 80 × 2,5	2,5	EN 10346 - DX51D + Z275
MK	60 × 60 × 100 × 2,5	2,5	EN 10346 - DX51D + Z275
MK	80 × 80 × 100 × 2,5	2,5	EN 10346 - DX51D + Z275
MK	100 × 100 × 100 × 2,5	2,5	EN 10346 - DX51D + Z275
<sup>1)</sup> requirements according angle brackets manufacturer's UAB "Ardetas" documentation: <ul style="list-style-type: none"> <li>- minimum yield strength, <math>R_{p0,2}</math> or <math>R_{eL}</math> – 250 MPa;</li> <li>- minimum tensile strength, <math>R_m</math> – 330 MPa;</li> <li>- minimum elongation, <math>A_{80}</math> – 22 % (according requirements of EN 10346:2009)</li> </ul>			

**Table A.1.** Steel for angle brackets specification (continued)

Angle bracket type		Steel thickness (mm)	Steel and coating specification <sup>1)</sup>
<b>Isosceles Angle brackets with additional holes</b>			
MK	50 × 50 × 35 × 2,0	2,0	EN 10346 - DX51D + Z275
MK	50 × 50 × 35 × 2,5	2,5	EN 10346 - DX51D + Z275
MK	50 × 50 × 50 × 2,0	2,0	EN 10346 - DX51D + Z275
MK	60 × 60 × 50 × 2,0	2,0	EN 10346 - DX51D + Z275
MK	60 × 60 × 50 × 2,5	2,5	EN 10346 - DX51D + Z275
MK	70 × 70 × 55 × 2,0	2,0	EN 10346 - DX51D + Z275
MK	70 × 70 × 55 × 2,5	2,5	EN 10346 - DX51D + Z275
MK	90 × 90 × 40 × 2,0	2,0	EN 10346 - DX51D + Z275
MK	90 × 90 × 40 × 2,5	2,5	EN 10346 - DX51D + Z275
MK	90 × 90 × 40 × 3,0	3,0	EN 10346 - DX51D + Z275
MK	90 × 90 × 65 × 2,0	2,0	EN 10346 - DX51D + Z275
MK	90 × 90 × 65 × 2,5	2,5	EN 10346 - DX51D + Z275
MK	100 × 100 × 90 × 2,0	2,0	EN 10346 - DX51D + Z275
MK	100 × 100 × 90 × 2,5	2,5	EN 10346 - DX51D + Z275
MK	105 × 105 × 90 × 3,0	3,0	EN 10346 - DX51D + Z275
<b>Isosceles Angle brackets with a rib</b>			
MKS	50 × 50 × 35 × 2,0	2,0	EN 10346 - DX51D + Z275
MKS	50 × 50 × 35 × 2,5	2,5	EN 10346 - DX51D + Z275
MKS	50 × 50 × 50 × 2,0	2,0	EN 10346 - DX51D + Z275
MKS	50 × 50 × 50 × 2,5	2,5	EN 10346 - DX51D + Z275
MKS	60 × 60 × 50 × 2,0	2,0	EN 10346 - DX51D + Z275
MKS	60 × 60 × 50 × 2,5	2,5	EN 10346 - DX51D + Z275
MKS	70 × 70 × 55 × 2,0	2,0	EN 10346 - DX51D + Z275
MKS	70 × 70 × 55 × 2,5	2,5	EN 10346 - DX51D + Z275
MKS	70 × 70 × 65 × 2,0	2,0	EN 10346 - DX51D + Z275
MKS	90 × 90 × 50 × 2,0	2,0	EN 10346 - DX51D + Z275
MKS	90 × 90 × 50 × 2,5	2,5	EN 10346 - DX51D + Z275
MKS	90 × 90 × 65 × 2,0	2,0	EN 10346 - DX51D + Z275
MKS	90 × 90 × 65 × 2,5	2,5	EN 10346 - DX51D + Z275
MKS	100 × 100 × 90 × 2,0	2,0	EN 10346 - DX51D + Z275
MKS	100 × 100 × 90 × 2,5	2,5	EN 10346 - DX51D + Z275
MKS	105 × 105 × 90 × 3,0	3,0	EN 10346 - DX51D + Z275
<sup>1)</sup> requirements according angle brackets manufacturer's UAB "Ardetas" documentation: - minimum yield strength, $R_{p0,2}$ or $R_{eL}$ – 250 MPa; - minimum tensile strength, $R_m$ – 330 MPa; - minimum elongation, $A_{80}$ – 22 % (according requirements of EN 10346:2009)			

**Table A.1.** Steel for angle brackets specification (continued)

Angle bracket type		Steel thickness (mm)	Steel and coating specification <sup>1)</sup>
Non-isosceles Angle brackets with a rib			
MKNS	90 × 50 × 50 × 2,0	2,0	EN 10346 - DX51D + Z275
MKNS	90 × 50 × 50 × 2,5	2,5	EN 10346 - DX51D + Z275
MKNS	150 × 90 × 65 × 2,0	2,0	EN 10346 - DX51D + Z275
MKNS	150 × 90 × 65 × 2,5	2,5	EN 10346 - DX51D + Z275
MKNS	150 × 100 × 90 × 2,0	2,0	EN 10346 - DX51D + Z275
MKNS	150 × 100 × 90 × 2,5	2,5	EN 10346 - DX51D + Z275
Non-isosceles Angle brackets			
MKN	120 × 40 × 40 × 2,0	2,0	EN 10346 - DX51D + Z275
MKN	80 × 40 × 40 × 2,0	2,0	EN 10346 - DX51D + Z275
MKN	120 × 40 × 60 × 2,0	2,0	EN 10346 - DX51D + Z275
MKN	80 × 40 × 60 × 2,0	2,0	EN 10346 - DX51D + Z275
MKN	100 × 60 × 60 × 2,0	2,0	EN 10346 - DX51D + Z275
MKN	200 × 40 × 40 × 2,0	2,0	EN 10346 - DX51D + Z275
Non-isosceles Angle brackets with additional holes			
MKN	90 × 50 × 50 × 2,0	2,0	EN 10346 - DX51D + Z275
MKN	90 × 50 × 50 × 2,5	2,5	EN 10346 - DX51D + Z275
MKN	95 × 45 × 40 × 2,5	2,5	EN 10346 - DX51D + Z275
MKN	135 × 45 × 40 × 2,0	2,0	EN 10346 - DX51D + Z275
MKN	135 × 45 × 40 × 2,5	2,5	EN 10346 - DX51D + Z275
<sup>1)</sup> requirements according angle brackets manufacturer's UAB "Ardetas" documentation: - minimum yield strength, $R_{p0,2}$ or $R_{eL}$ – 250 MPa; - minimum tensile strength, $R_m$ – 330 MPa; - minimum elongation, $A_{80}$ – 22 % (according requirements of EN 10346:2009)			

The angle brackets drawings with dimensions presented in the Annex C.

**Table A.2.** Nails specification

Nail type according EN 14592	Dimensions (mm)	Coating specification
GBO Fastening systems AB nail	40 × 4,0	12 μm (ISO 2081 - Fe/Zn12/C)
Characteristic capacities of nails for a characteristic density of the wood members 350 kg/m <sup>3</sup> : - characteristic withdrawal capacity, $f_{ax,k}$ – 7,8 N/mm <sup>2</sup> ; - characteristic yield moment, $M_{y,RK}$ – 7168 Nmm; Tensile capacity of the wire for nails – 650 N/mm <sup>2</sup> .		

## ANNEX B

### Characteristic load-carrying capacities

#### B.1 Support conditions

The distance between the timber members in the area of the connection must not exceed 3 mm. The members shall be prevented from rotation.

#### B.2 Fastener specification

Number and position of nails presented in the Table B.1-B.4 and Annex D.

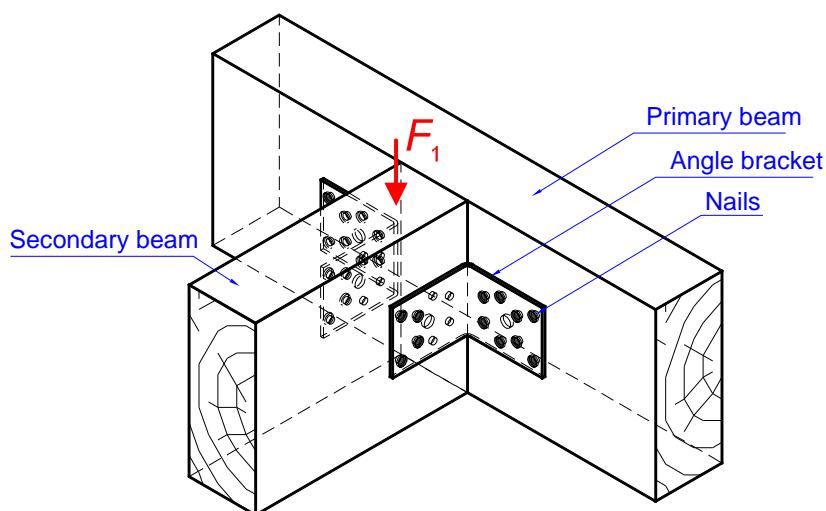
#### B.3 Wane

Wane is not allowed, the timber has to be sharp-edged in the area of the contact with the angle brackets.

#### B.4 Characteristic load-carrying capacities

##### B.4.1 Timber beam to timber column connections with the angle brackets

The calculation model of timber beam to timber beam connection with the angle brackets is showed in the Figure 2.



**Figure B.1.** Typical installation of the angle brackets in the timber beam to timber beam connections

**Table B.1.** Characteristic load-carrying capacities  $F_{1,k}$  of timber beam to timber beam connection for load direction according Figure B.1.

Angle bracket type		Nails dimensions (mm)	Number of nails in		Position of nails shown in Figure <sup>1)</sup>	$F_{1,k}$ kN
			primary beam	secondary beam		
Isosceles Angle brackets						
MK	60 × 60 × 40 × 2,0	4,0x40	8	6	D.1	1,56
MK	80 × 80 × 40 × 2,0	4,0x40	12	6	D.2	1,15
MK	60 × 60 × 60 × 2,0	4,0x40	14	6	D.3	1,41
MK	80 × 80 × 60 × 2,0	4,0x40	20	10	D.4	2,05
MK	100 × 100 × 60 × 2,0	4,0x40	24	16	D.5	3,97
MK	60 × 60 × 80 × 2,0	4,0x40	20	8	D.6	2,23
MK	80 × 80 × 80 × 2,0	4,0x40	28	14	D.7	3,26
MK	100 × 100 × 80 × 2,0	4,0x40	34	22	D.8	5,70
MK	60 × 60 × 100 × 2,0	4,0x40	26	10	D.9	3,19
MK	80 × 80 × 100 × 2,0	4,0x40	36	18	D.10	4,31
MK	100 × 100 × 100 × 2,0	4,0x40	44	28	D.11	7,78
MK	60 × 60 × 40 × 2,5	4,0x40	8	6	D.12	1,80
MK	80 × 80 × 40 × 2,5	4,0x40	12	6	D.13	1,33
MK	60 × 60 × 60 × 2,5	4,0x40	14	6	D.14	1,62
MK	80 × 80 × 60 × 2,5	4,0x40	20	10	D.15	2,37
MK	100 × 100 × 60 × 2,5	4,0x40	24	16	D.16	4,57
MK	60 × 60 × 80 × 2,5	4,0x40	20	8	D.17	2,57
MK	80 × 80 × 80 × 2,5	4,0x40	28	14	D.18	3,76
MK	100 × 100 × 80 × 2,5	4,0x40	34	22	D.19	6,58
MK	60 × 60 × 100 × 2,5	4,0x40	26	10	D.20	3,68
MK	80 × 80 × 100 × 2,5	4,0x40	36	18	D.21	4,97
MK	100 × 100 × 100 × 2,5	4,0x40	44	28	D.22	8,98
<sup>1)</sup> see Annex D						

**Table B.1.** Characteristic load-carrying capacities  $F_{1,k}$  of timber beam to timber beam connection for load direction according Figure B.1 (continued).

Angle bracket type		Nails dimensions (mm)	Number of nails in		Position of nails shown in Figure <sup>1)</sup>	$F_{1,k}$ kN
			primary beam	secondary beam		
Isosceles Angle brackets with additional holes						
MK	50 × 50 × 35 × 2,0	4,0x40	8	4	D.23	0,89
MK	50 × 50 × 35 × 2,5	4,0x40	8	4	D.23	1,03
MK	50 × 50 × 50 × 2,0	4,0x40	8	4	D.24	1,21
MK	60 × 60 × 50 × 2,0	4,0x40	8	4	D.25	1,20
MK	60 × 60 × 50 × 2,5	4,0x40	8	4	D.25	1,38
MK	70 × 70 × 55 × 2,0	4,0x40	14	6	D.26	1,10
MK	70 × 70 × 55 × 2,5	4,0x40	14	6	D.26	1,27
MK	90 × 90 × 40 × 2,0	4,0x40	16	8	D.27	1,82
MK	90 × 90 × 40 × 2,5	4,0x40	16	8	D.27	2,10
MK	90 × 90 × 40 × 3,0	4,0x40	16	8	D.27	2,39
MK	90 × 90 × 65 × 2,0	4,0x40	12	8	D.28	2,93
MK	90 × 90 × 65 × 2,5	4,0x40	12	8	D.28	3,38
MK	100 × 100 × 90 × 2,0	4,0x40	12	8	D.29	2,31
MK	100 × 100 × 90 × 2,5	4,0x40	12	8	D.29	2,67
MK	105 × 105 × 90 × 3,0	4,0x40	12	8	D.30	3,04
Isosceles Angle brackets with a rib						
MKS	50 × 50 × 35 × 2,0	4,0x40	8	4	D.31	0,89
MKS	50 × 50 × 35 × 2,5	4,0x40	8	4	D.31	1,03
MKS	50 × 50 × 50 × 2,0	4,0x40	8	4	D.32	1,21
MKS	50 × 50 × 50 × 2,5	4,0x40	8	4	D.32	1,39
MKS	60 × 60 × 50 × 2,0	4,0x40	8	4	D.33	1,20
MKS	60 × 60 × 50 × 2,5	4,0x40	8	4	D.33	1,38
MKS	70 × 70 × 55 × 2,0	4,0x40	14	6	D.34	1,10
MKS	70 × 70 × 55 × 2,5	4,0x40	14	6	D.34	1,27
MKS	70 × 70 × 65 × 2,0	4,0x40	8	4	D.35	1,43
MKS	90 × 90 × 50 × 2,0	4,0x40	16	12	D.36	3,62
MKS	90 × 90 × 50 × 2,5	4,0x40	16	12	D.36	4,17
MKS	90 × 90 × 65 × 2,0	4,0x40	12	8	D.37	2,93
MKS	90 × 90 × 65 × 2,5	4,0x40	12	8	D.37	3,38
MKS	100 × 100 × 90 × 2,0	4,0x40	12	8	D.38	2,31
MKS	100 × 100 × 90 × 2,5	4,0x40	12	8	D.38	2,67
MKS	105 × 105 × 90 × 3,0	4,0x40	12	8	D.39	3,04
<sup>1)</sup> see Annex D						



**Table B.1.** Characteristic load-carrying capacities  $F_{1,k}$  of timber beam to timber beam connection for load direction according Figure B.1 (continued).

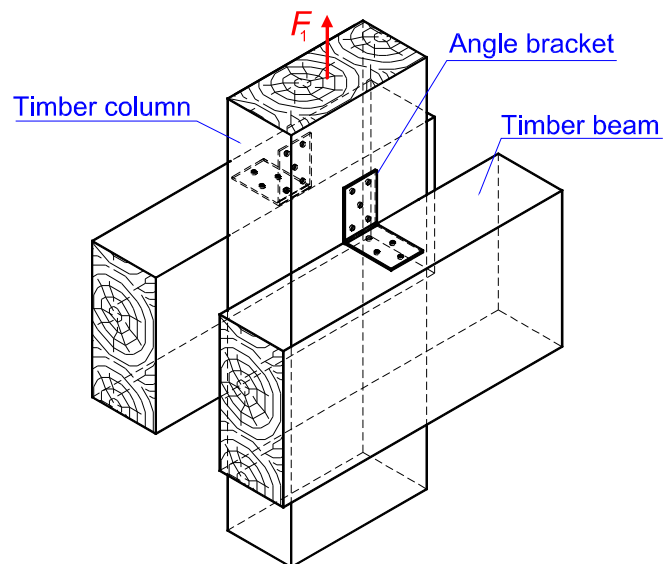
Angle bracket type		Nails dimensions (mm)	Number of nails in		Position of nails shown in Figure <sup>1)</sup>	$F_{1,k}$ kN
			primary beam	secondary beam		
Non-isosceles Angle brackets with a rib						
MKNS	90 × 50 × 50 × 2,0	4,0x40	8	12	D.40	3,46
MKNS	90 × 50 × 50 × 2,5	4,0x40	8	12	D.40	3,81
MKNS	150 × 90 × 65 × 2,0	4,0x40	12	20	D.41	2,29
MKNS	150 × 90 × 65 × 2,5	4,0x40	12	20	D.41	2,61
MKNS	150 × 100 × 90 × 2,0	4,0x40	8	16	D.42	4,91
MKNS	150 × 100 × 90 × 2,5	4,0x40	8	16	D.42	5,39
Non-isosceles Angle brackets						
MKN	120 × 40 × 40 × 2,0	4,0x40	6	12	D.43	1,59
MKN	80 × 40 × 40 × 2,0	4,0x40	6	6	D.44	0,99
MKN	120 × 40 × 60 × 2,0	4,0x40	10	20	D.45	3,72
MKN	80 × 40 × 60 × 2,0	4,0x40	10	10	D.46	2,05
MKN	100 × 60 × 60 × 2,0	4,0x40	16	14	D.47	2,75
MKN	200 × 40 × 40 × 2,0	4,0x40	6	24	D.48	1,21
Non-isosceles Angle brackets with additional holes						
MKN	90 × 50 × 50 × 2,0	4,0x40	8	12	D.49	3,46
MKN	90 × 50 × 50 × 2,5	4,0x40	8	12	D.49	3,81
MKN	95 × 45 × 40 × 2,5	4,0x40	8	8	D.50	2,10
MKN	135 × 45 × 40 × 2,0	4,0x40	8	16	D.51	2,35
MKN	135 × 45 × 40 × 2,5	4,0x40	8	16	D.51	2,46
<sup>1)</sup> see Annex D						

When load-carrying capacity is calculated the possibility of splinting caused by the tension perpendicular to the grain, shall be taken into account.

## B.4.2 Timber beam to timber column connections with the angle brackets

### B.4.2.1 Timber beam to timber column connections with the angle brackets at the top of the beam.

The calculation model of timber beam to timber column connection with the angle brackets is showed in the Figure B.2.



**Figure B.2.** Typical installation of the angle brackets in the timber beam to timber column connections. Angle brackets at the top of the beam

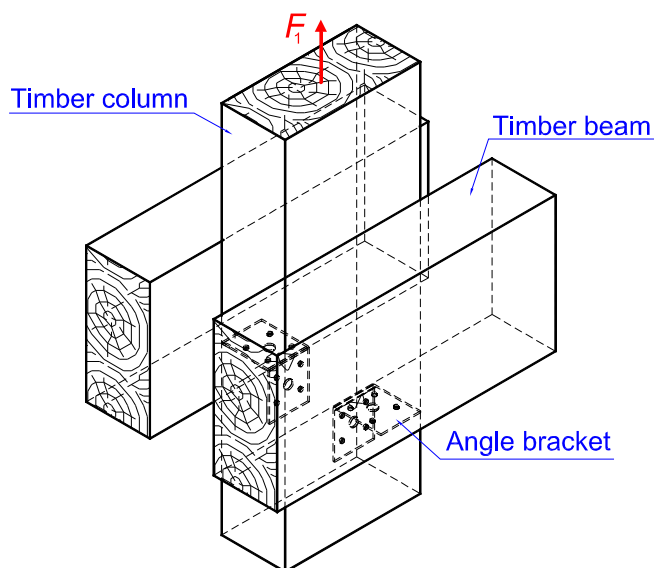
**Table B.2.** Characteristic load-carrying capacities  $F_{1,k}$  of timber beam to timber column connection for load direction according Figure B.2.

Angle bracket type		Nails dimensions (mm)	Number of nails in		Position of nails shown in Figure <sup>1)</sup>	$F_{1,k}$ kN
			column	beams		
Isosceles Angle brackets						
MK	60 × 60 × 40 × 2,0	4,0x40	2x5	2x3	D.52	2,78
MKS	60 × 60 × 50 × 2,0	4,0x40	2x4	2x2	D.53	2,78
<sup>1)</sup> see Annex D						

When load-carrying capacity is calculated the possibility of splinting caused by the tension perpendicular to the grain, shall be taken into account.

### B.4.2.2 Timber beam to timber column connections with the angle brackets under the beam

The calculation model of timber beam to timber beam connection with the angle brackets under the beam is showed in the Figure B.3.



**Figure B.3.** Typical installation of the angle brackets in the timber beam to timber column connections. Angle brackets under the beam

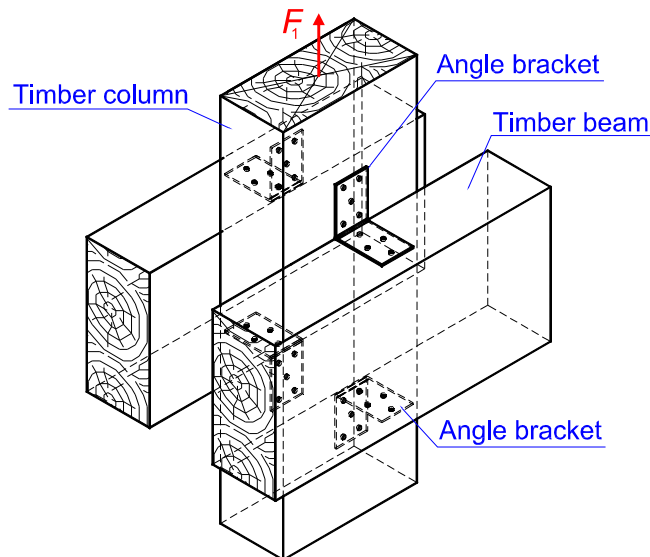
**Table B.3.** Characteristic load-carrying capacities  $F_{1,k}$  of timber beam to timber column connection for load direction according Figure B.3.

Angle bracket type		Nails dimensions (mm)	Number of nails in		Position of nails shown in Figure <sup>1)</sup>	$F_{1,k}$ kN
			column	beams		
Isosceles Angle brackets						
MK	60 × 60 × 40 × 2,0	4,0x40	2×5	2×3	D.54	5,10
MKS	60 × 60 × 50 × 2,0	4,0x40	2×4	2×2	D.55	6,71
<sup>1)</sup> see Annex D						

When load-carrying capacity is calculated the possibility of splinting caused by the tension perpendicular to the grain, shall be taken into account.

**B.4.2.3 Timber beam to timber column connections with the angle brackets in the vertical axis.**

The calculation model of timber beam to timber beam connection with the angle brackets placed in the vertical axis is showed in the Figure B.4.



**Figure B.4.** Calculation model of timber beam to timber column connection with a pair of angle brackets in vertical axis

**Table B.4.** Characteristic load-carrying capacities  $F_{1,k}$  of timber beam to timber column connection for load direction according Figure B.4.

Angle bracket type		Nails dimensions (mm)	Number of nails in		Position of nails shown in Figure <sup>1)</sup>	$F_{1,k}$ kN
			column	beams		
Isosceles Angle brackets						
MK	60 × 60 × 40 × 2,0	4,0x40	4x5	4x3	D.56	7,88
MKS	60 × 60 × 50 × 2,0	4,0x40	4x4	4x2	D.57	9,48
<sup>1)</sup> see Annex D						

When load-carrying capacity is calculated the possibility of splinting caused by the tension perpendicular to the grain, shall be taken into account.

## ANNEX C

### Angle brackets dimensions

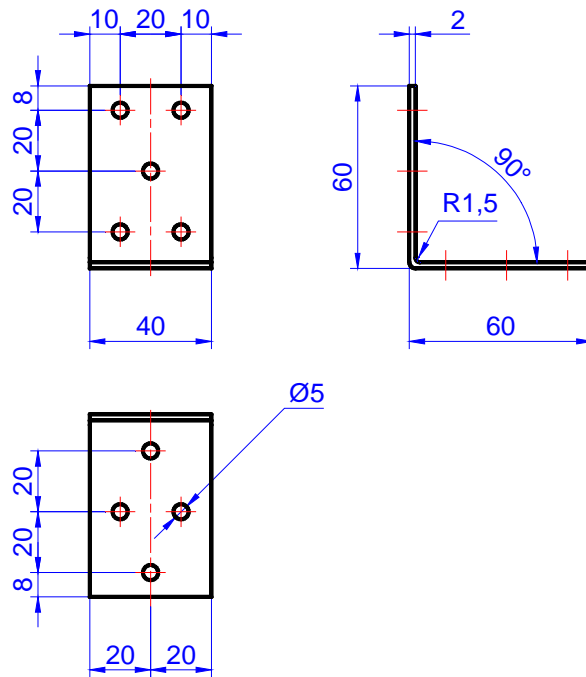


Figure C.1. Angle bracket MK 60 x 60 x 40 x 2,0

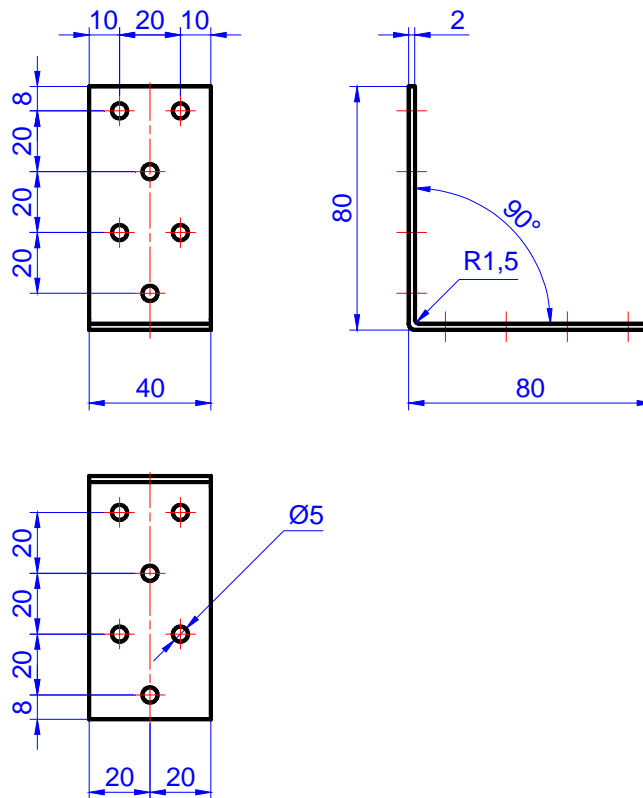


Figure C.2. Angle bracket MK 80 x 80 x 40 x 2,0

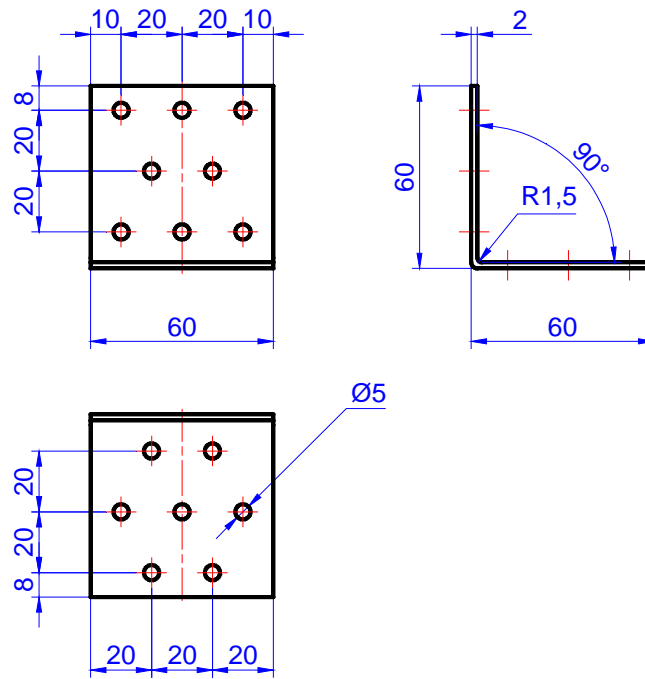


Figure C.3. Angle bracket MK 60 x 60 x 60 x 2,0

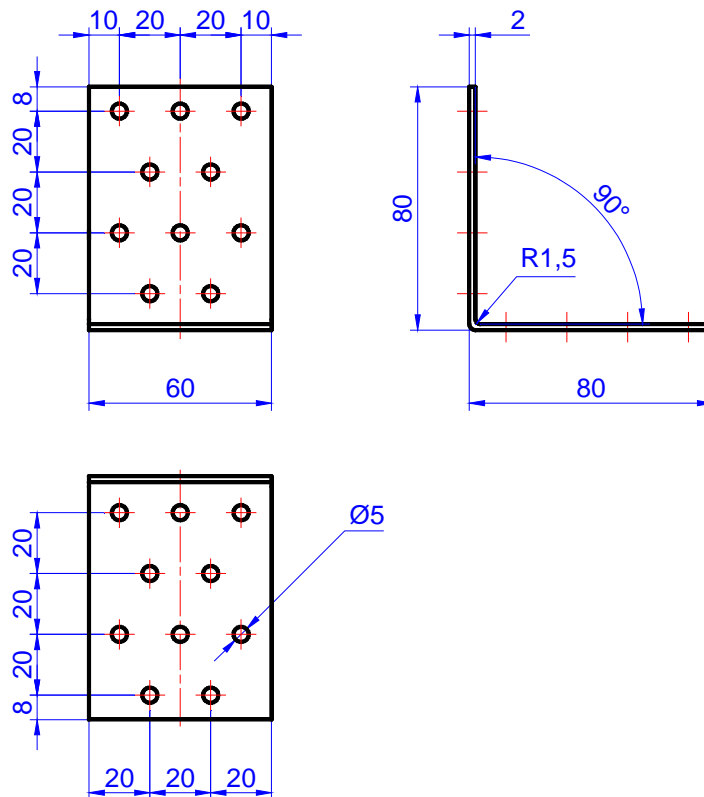
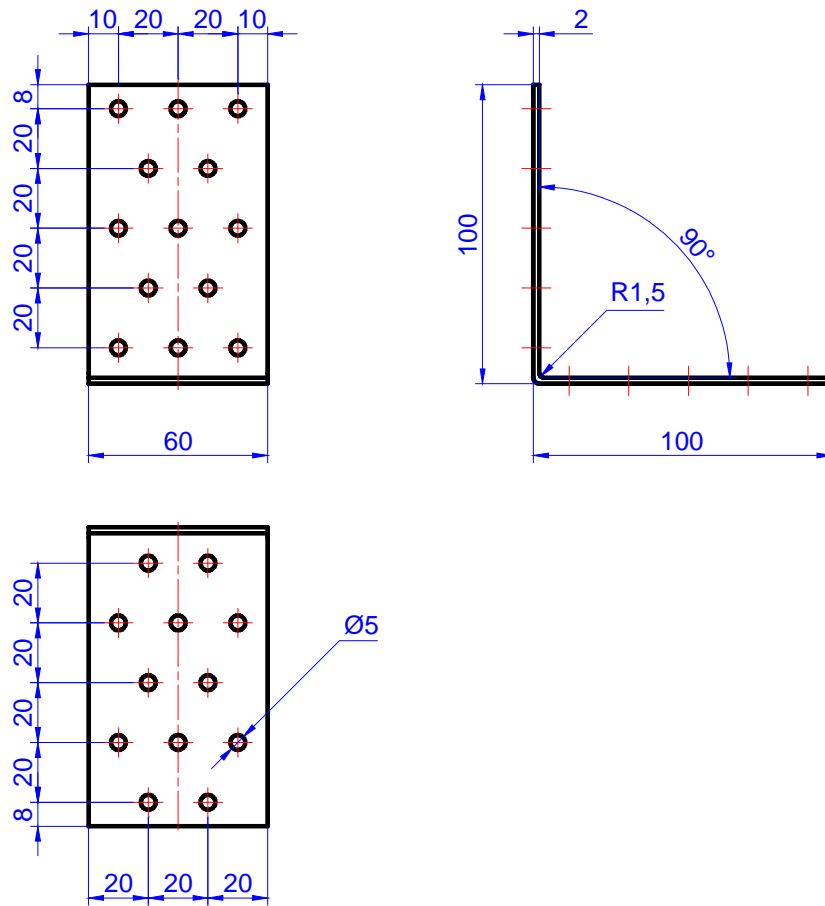
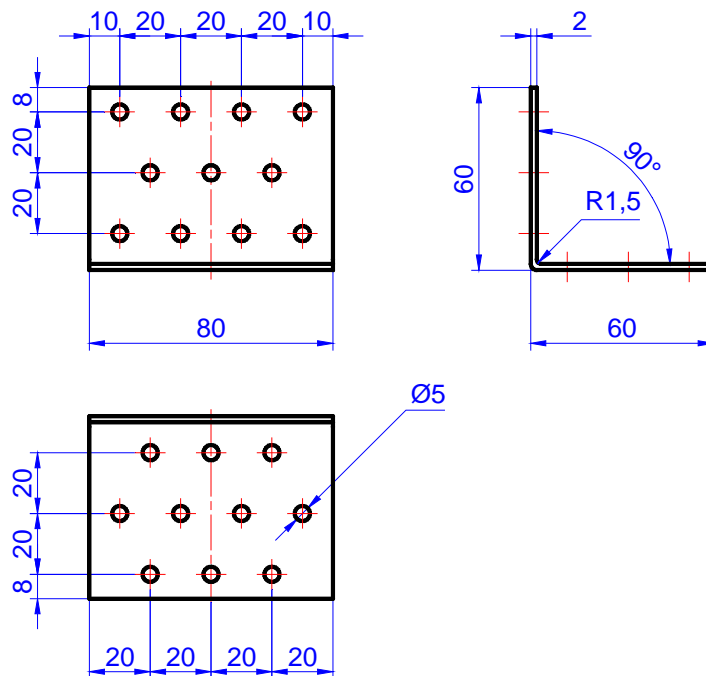


Figure C.4. Angle bracket MK 80 x 80 x 60 x 2,0



**Figure C.5.** Angle bracket MK 100 x 100 x 60 x 2,0



**Figure C.6.** Angle bracket MK 60 x 60 x 80 x 2,0

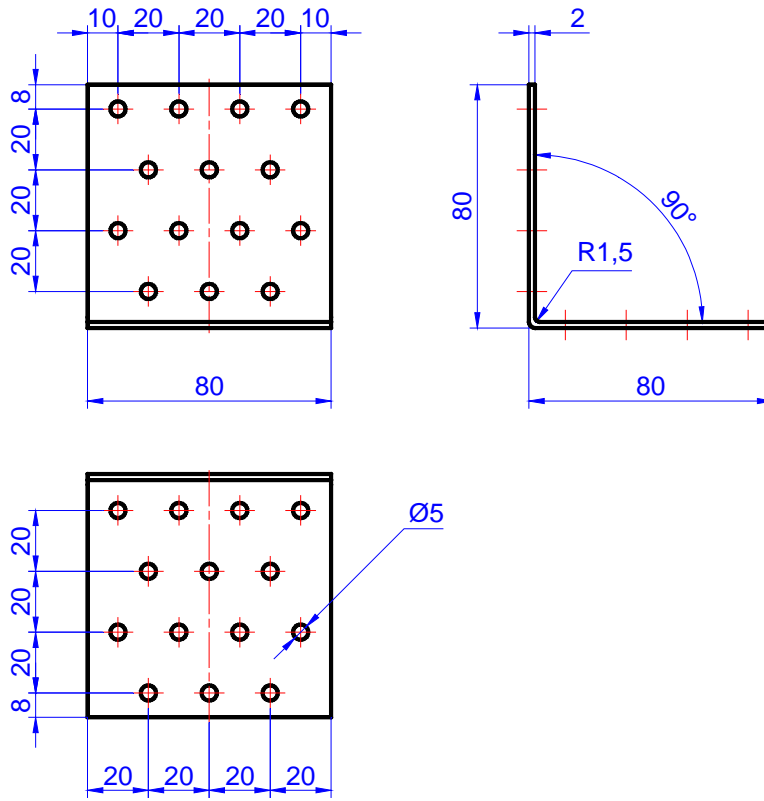


Figure C.7. Angle bracket MK 80 × 80 × 80 × 2,0

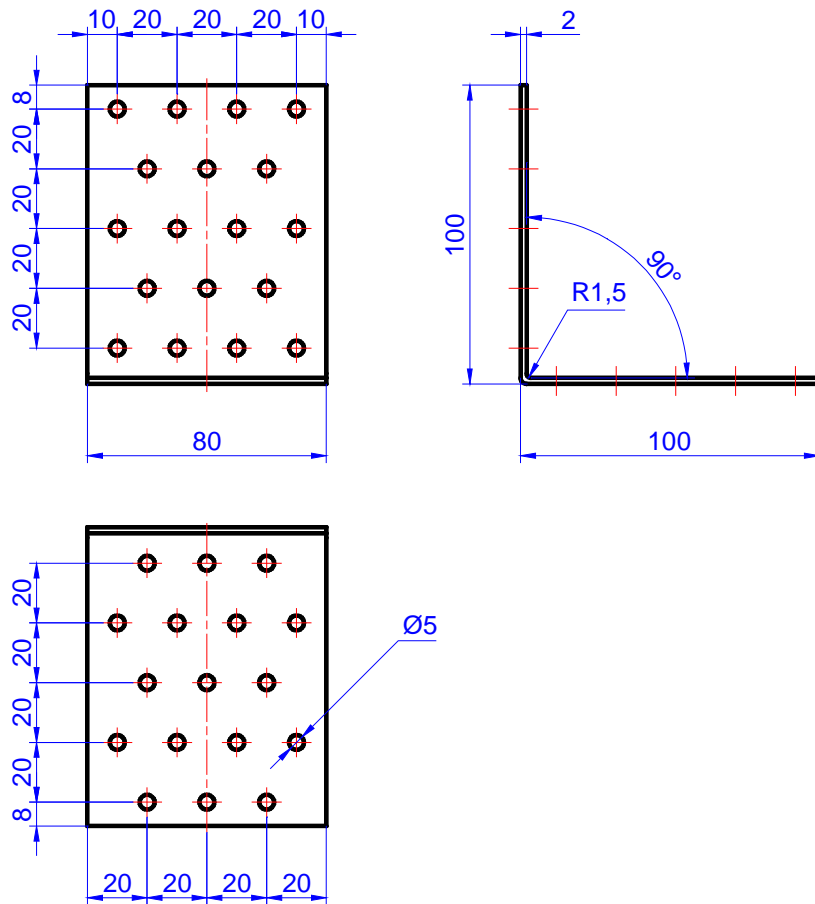
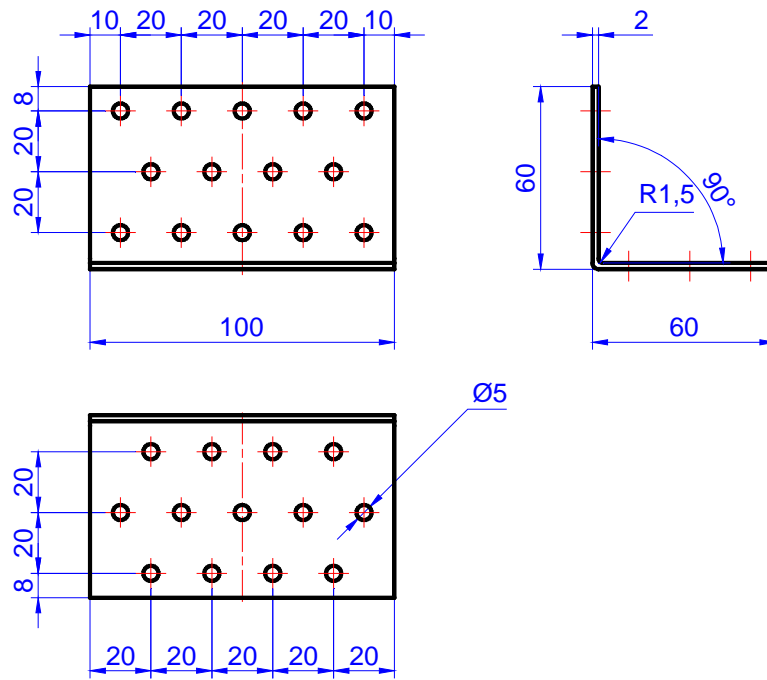
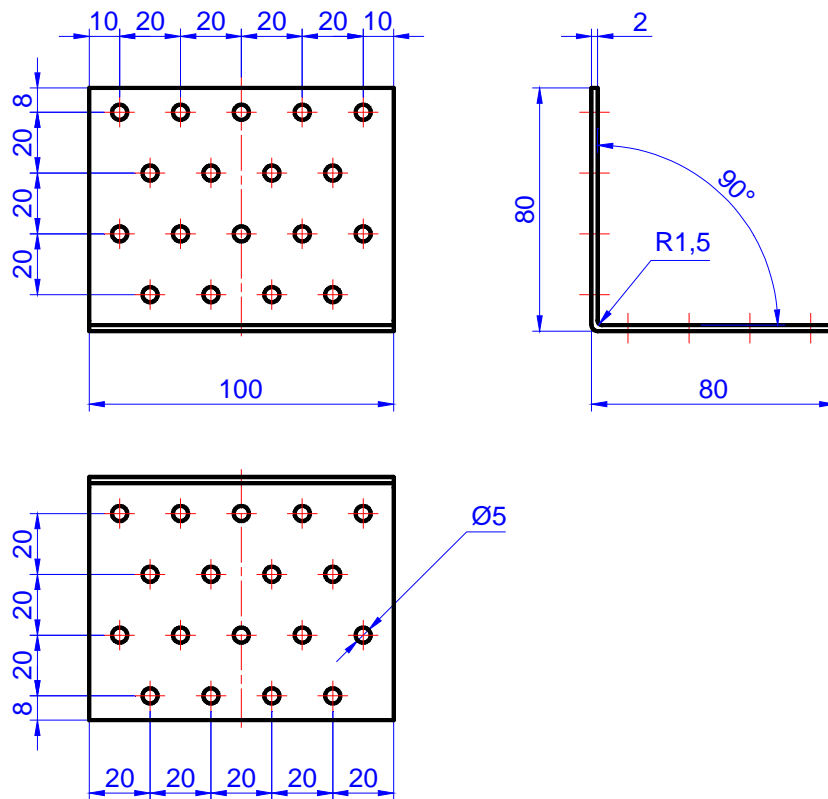


Figure C.8. Angle bracket MK 100 × 100 × 80 × 2,0





**Figure C.9.** Angle bracket MK 60 x 60 x 100 x 2,0



**Figure C.10.** Angle bracket MK 80 x 80 x 100 x 2,0

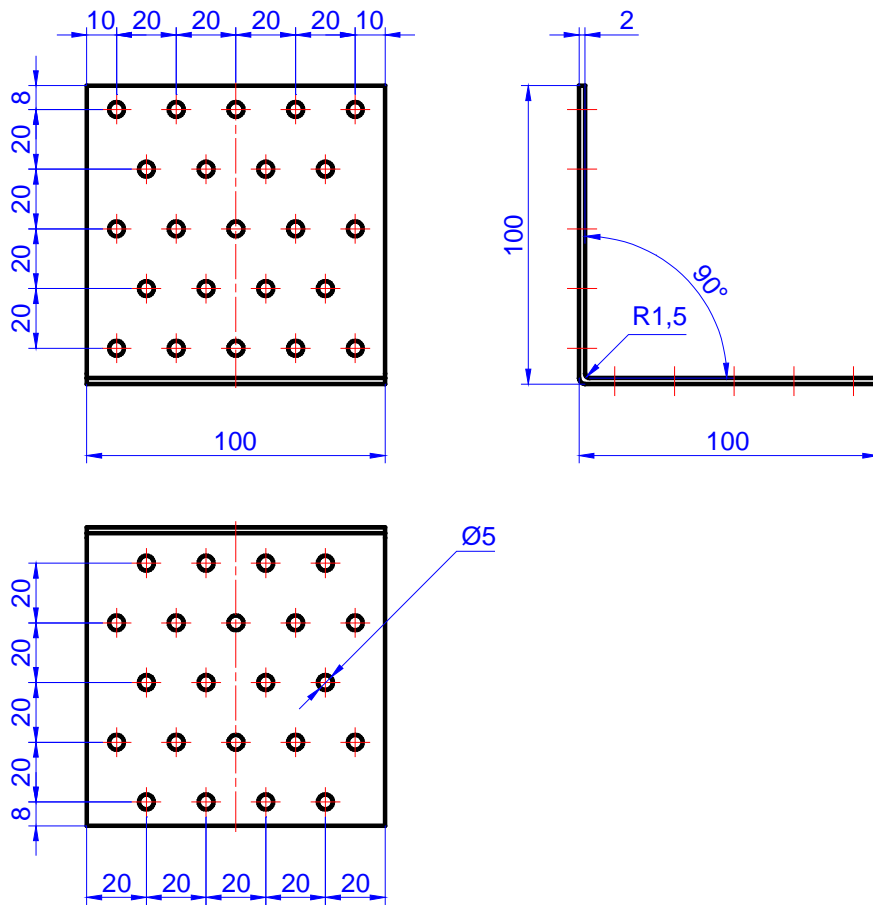


Figure C.1.1. Angle bracket MK 100 x 100 x 100 x 2,0

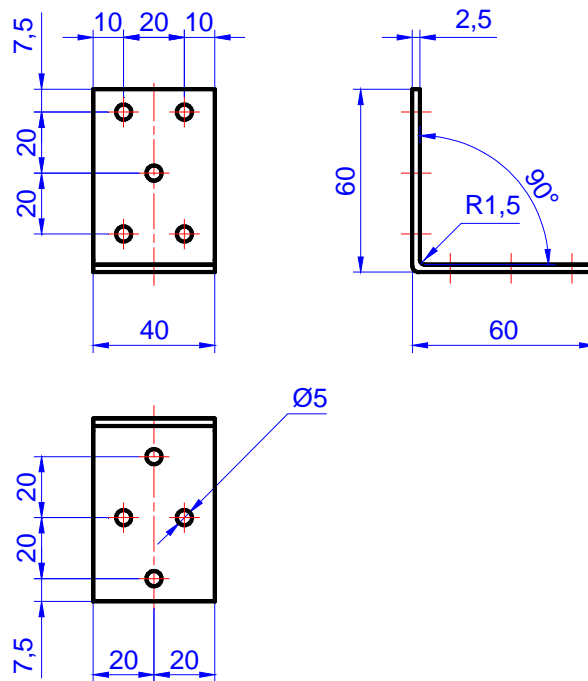
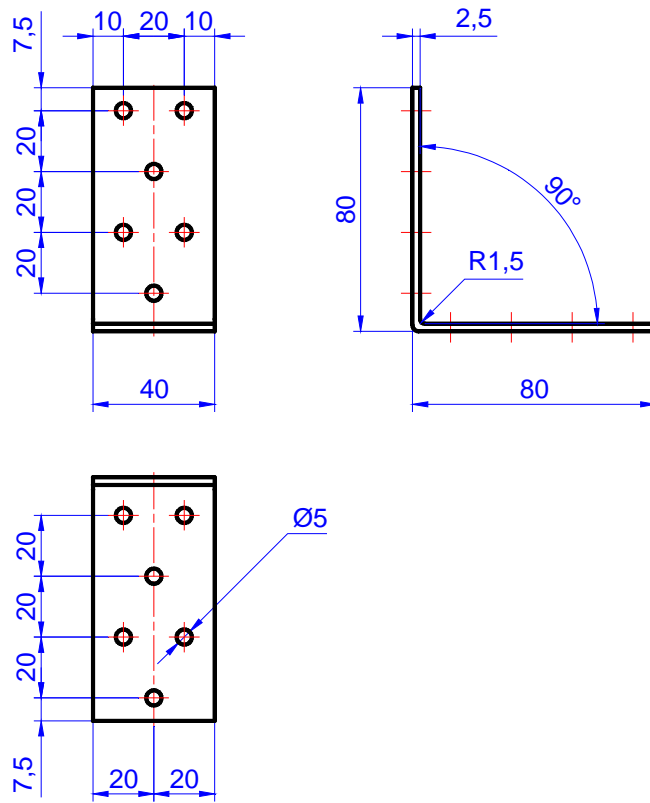
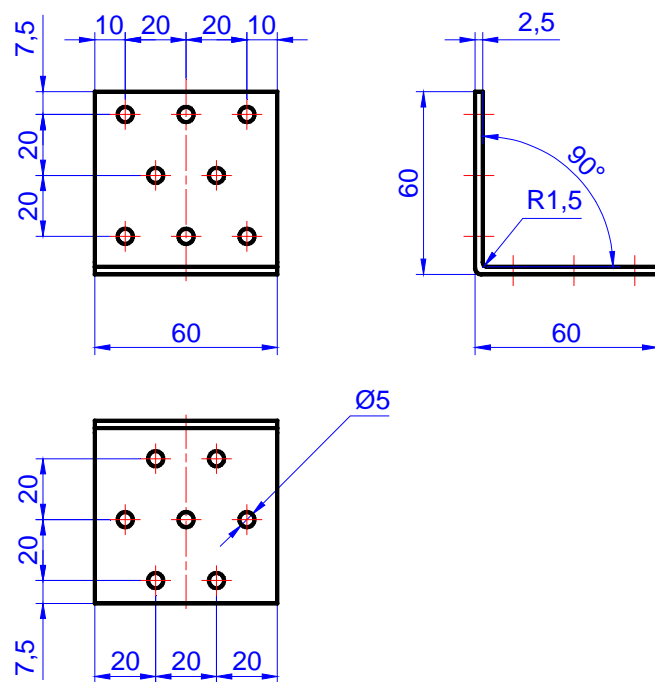


Figure C.12. Angle bracket MK 60 x 60 x 40 x 2,5



**Figure C.13.** Angle bracket MK 80 x 80 x 40 x 2,5



**Figure C.14.** Angle bracket MK 60 x 60 x 60 x 2,5

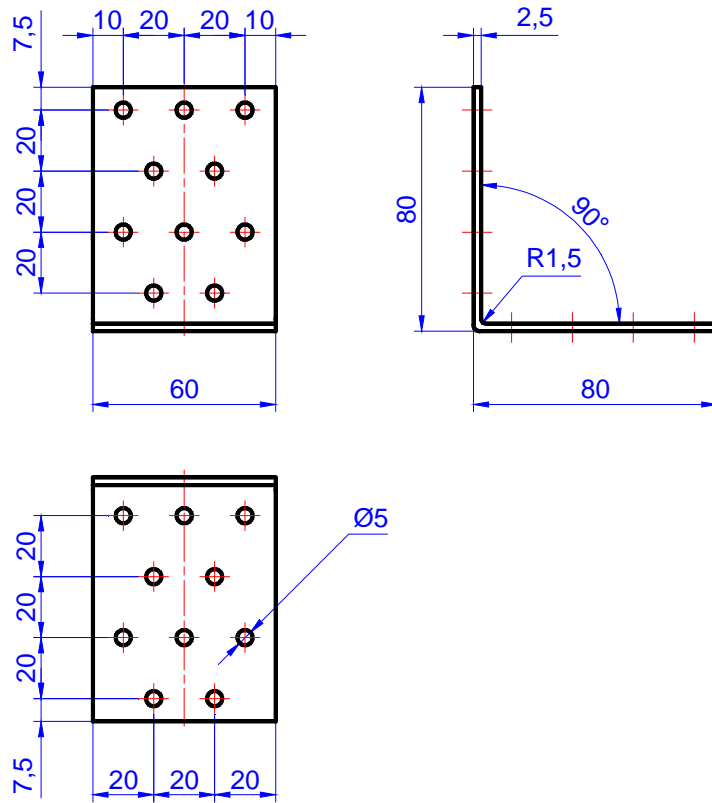


Figure C.15. Angle bracket MK 80 x 80 x 60 x 2,5

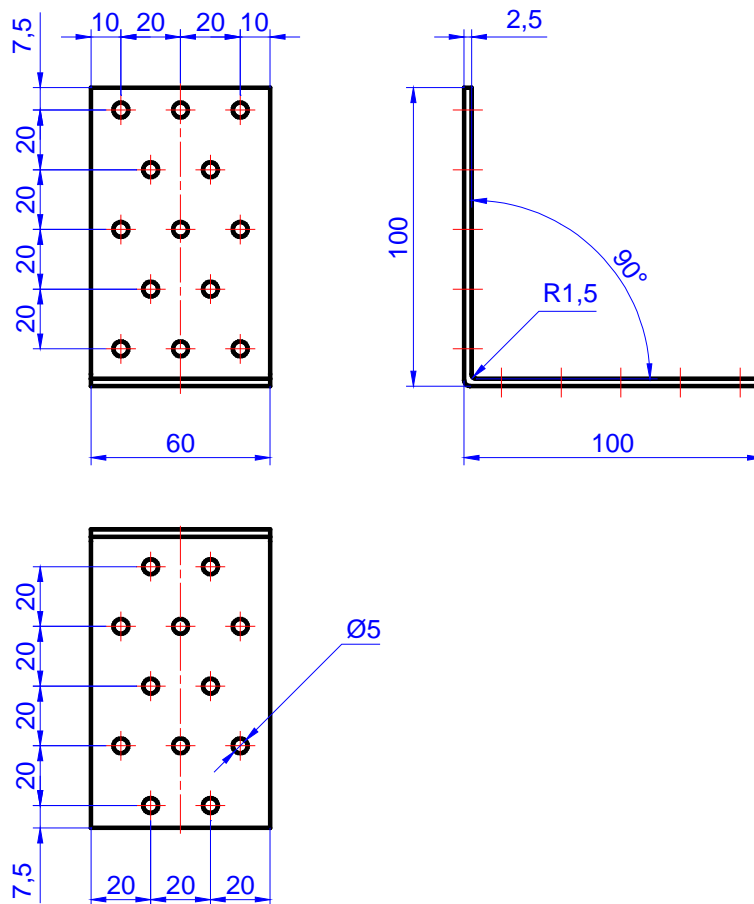
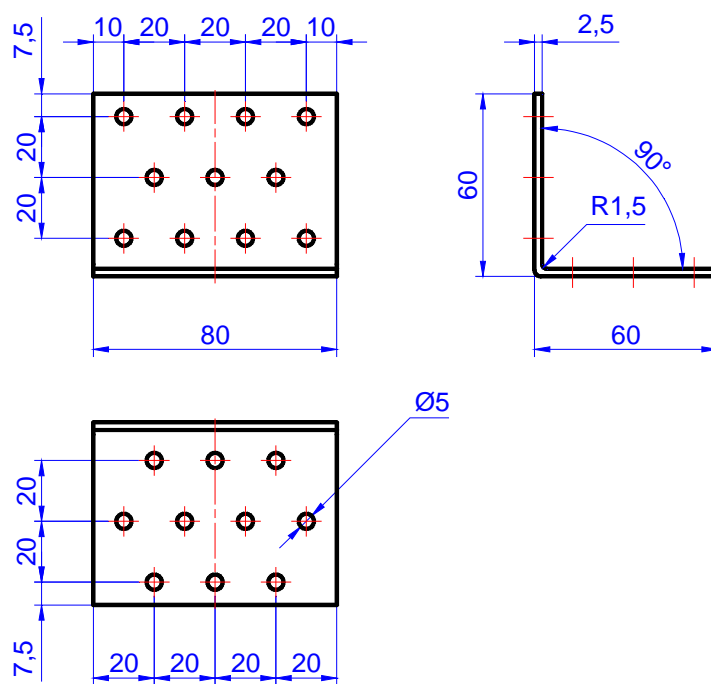
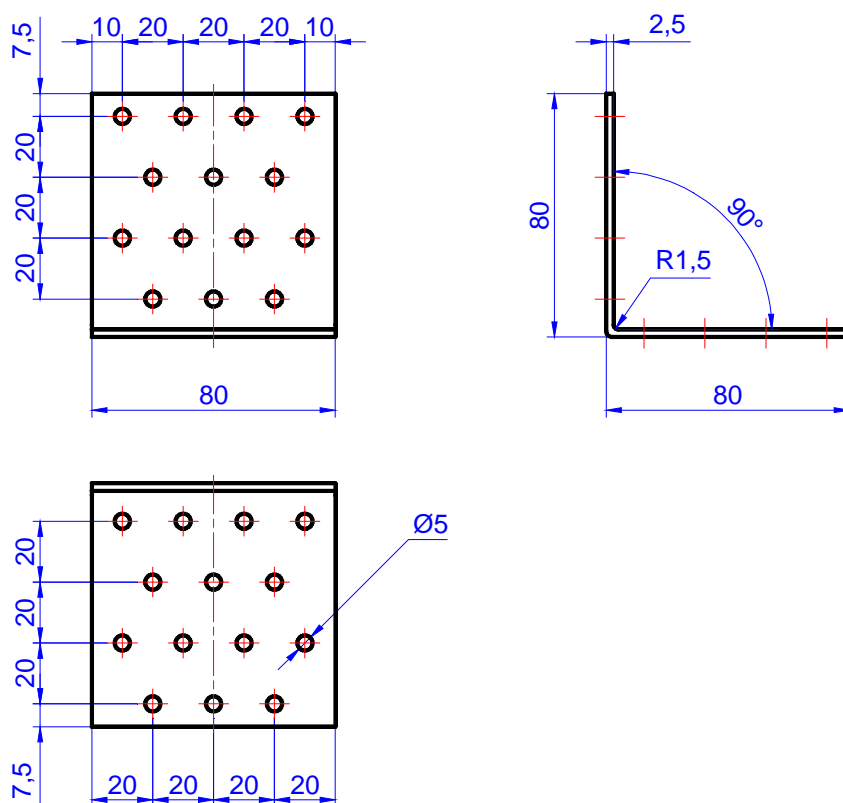


Figure C.16. Angle bracket MK 100 x 100 x 60 x 2,5



**Figure C.17.** Angle bracket MK 60 x 60 x 80 x 2,5



**Figure C.18.** Angle bracket MK 80 x 80 x 80 x 2,5

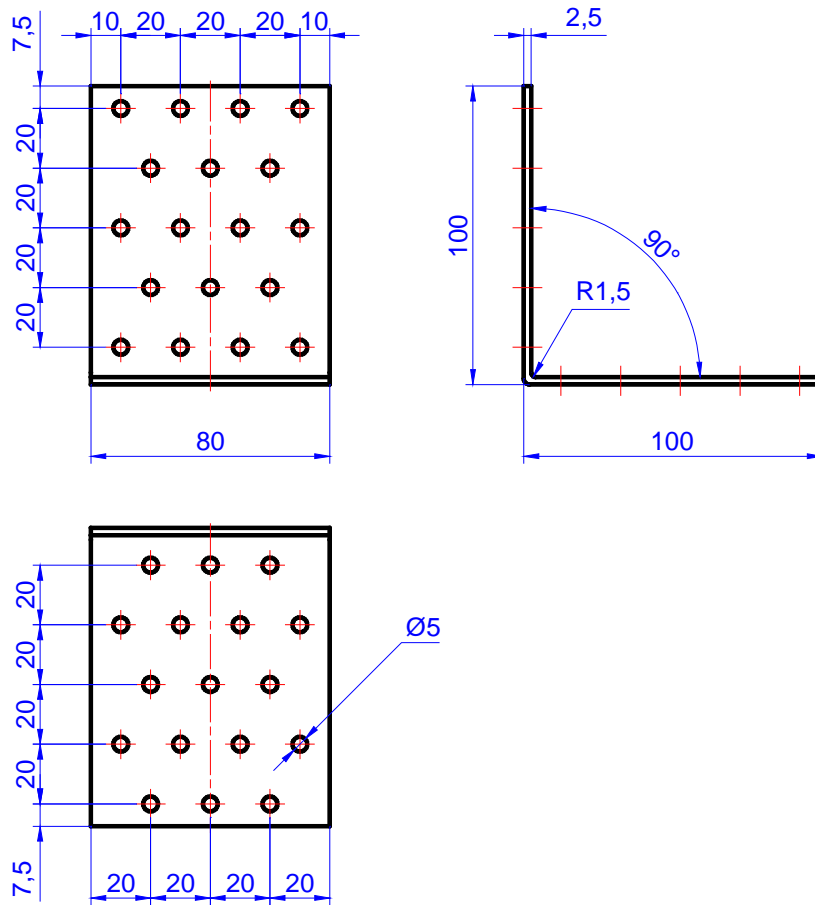


Figure C.19. Angle bracket MK 100 x 100 x 80 x 2,5

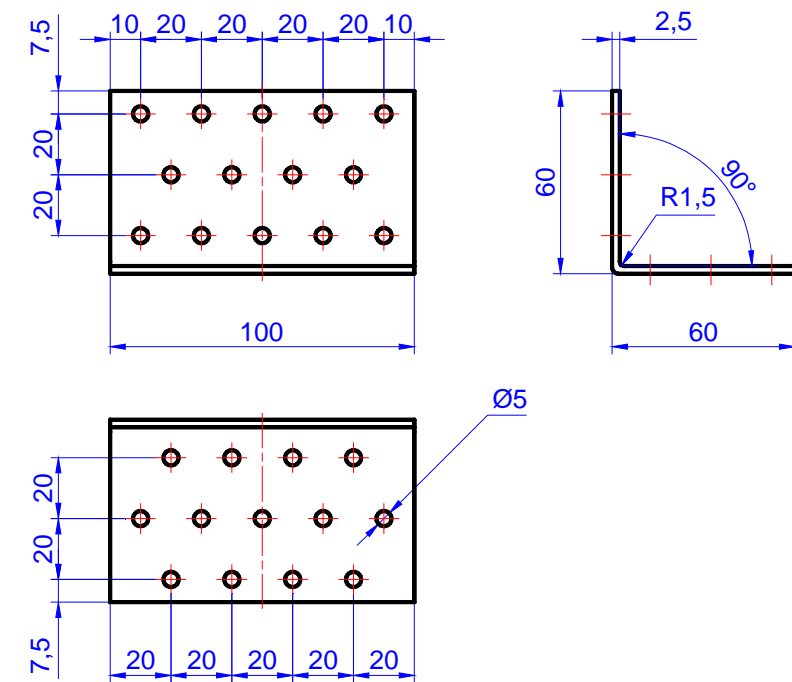


Figure C.20. Angle bracket MK 60 x 60 x 100 x 2,5

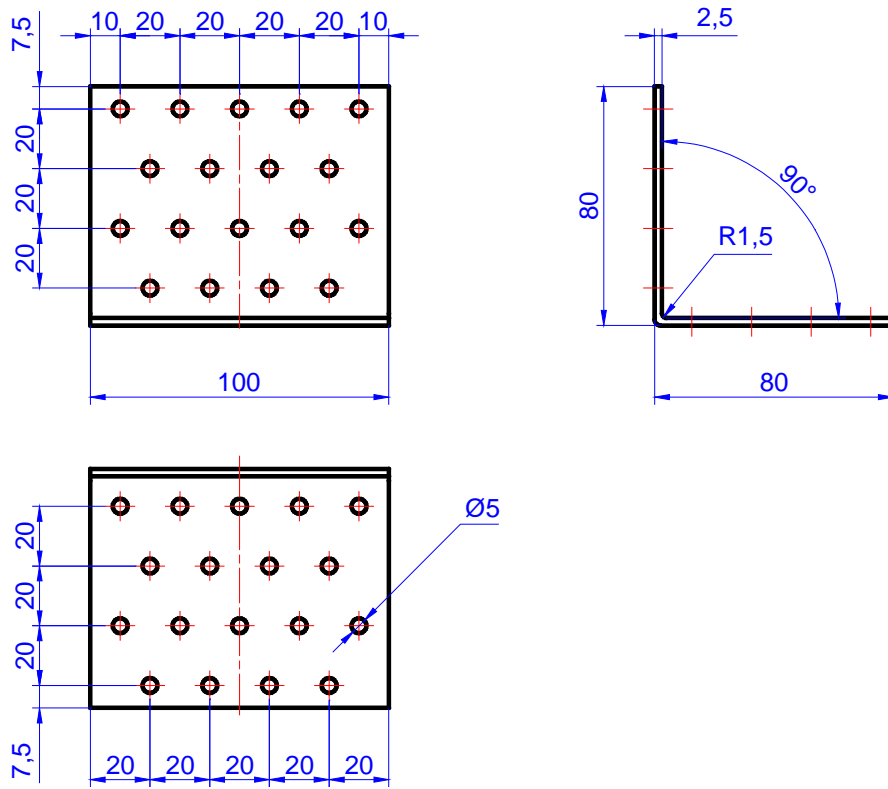


Figure C.21. Angle bracket MK 80 x 80 x 100 x 2,5

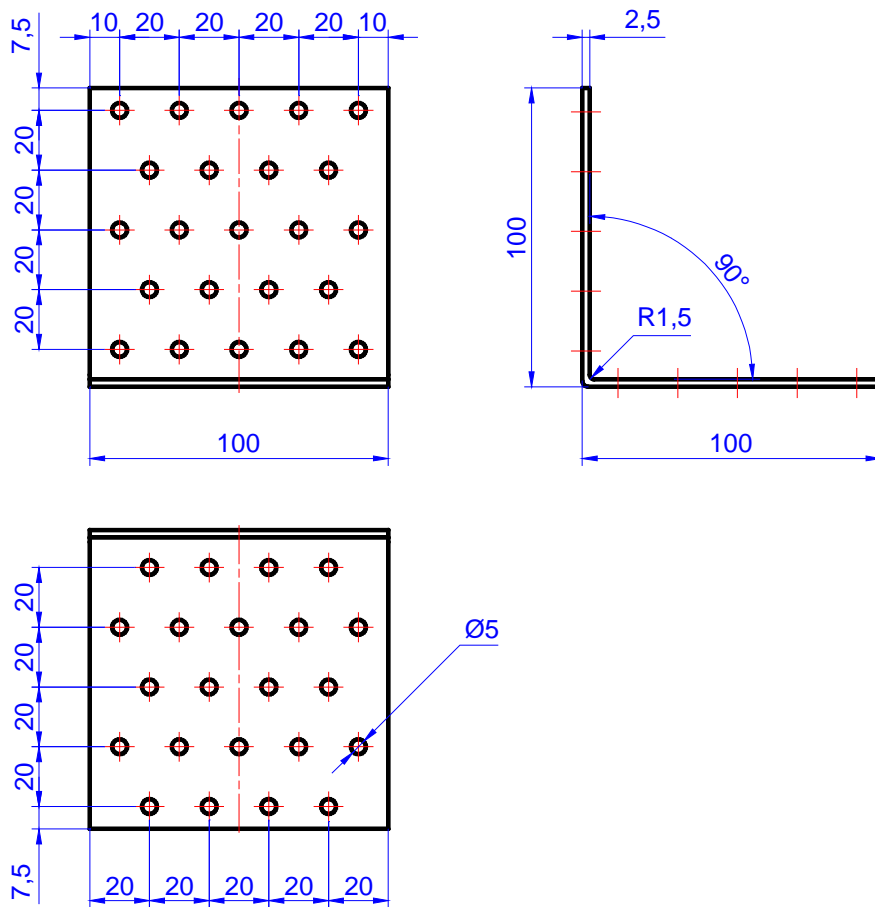
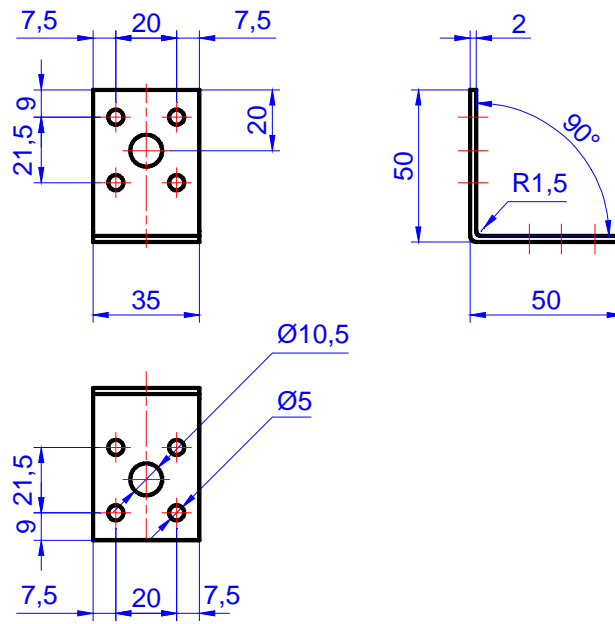
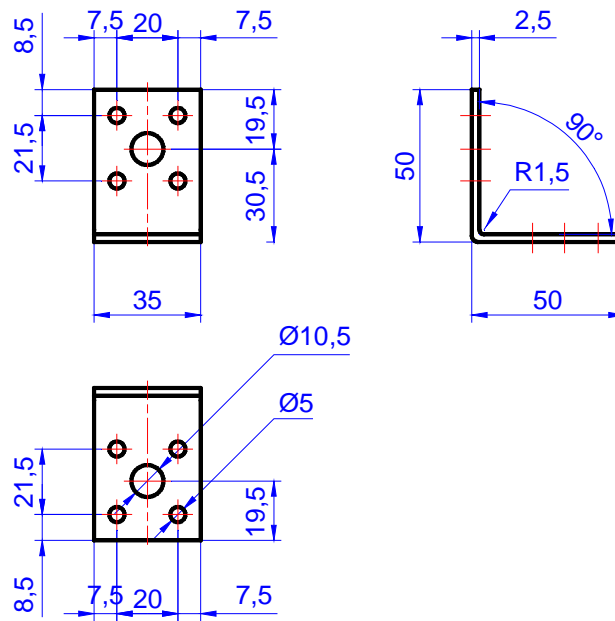


Figure C.22. Angle bracket MK 100 x 100 x 100 x 2,5

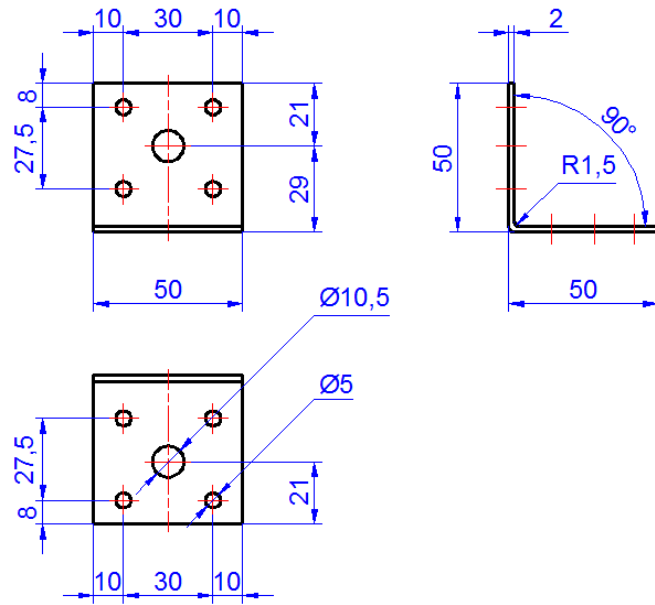


**Figure C.23.** Angle bracket MK 50 x 50 x 35 x 2,0

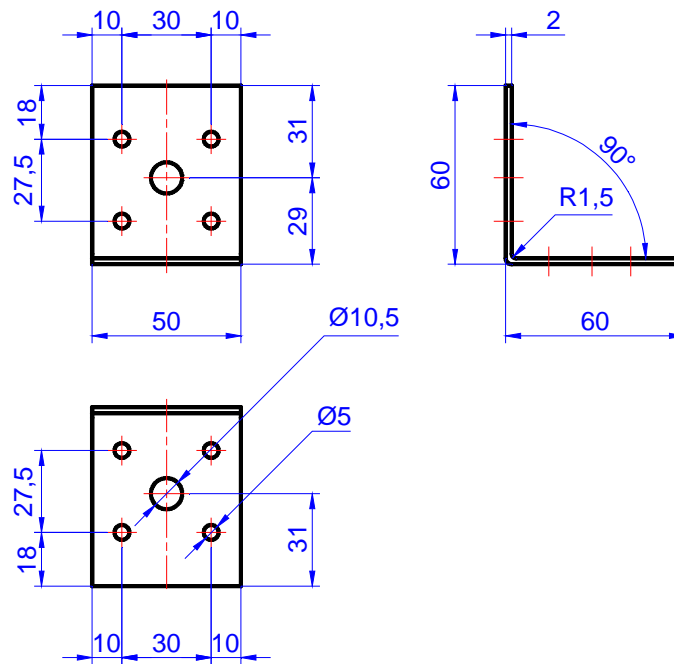


**Figure C.24.** Angle bracket MK 50 x 50 x 35 x 2,5

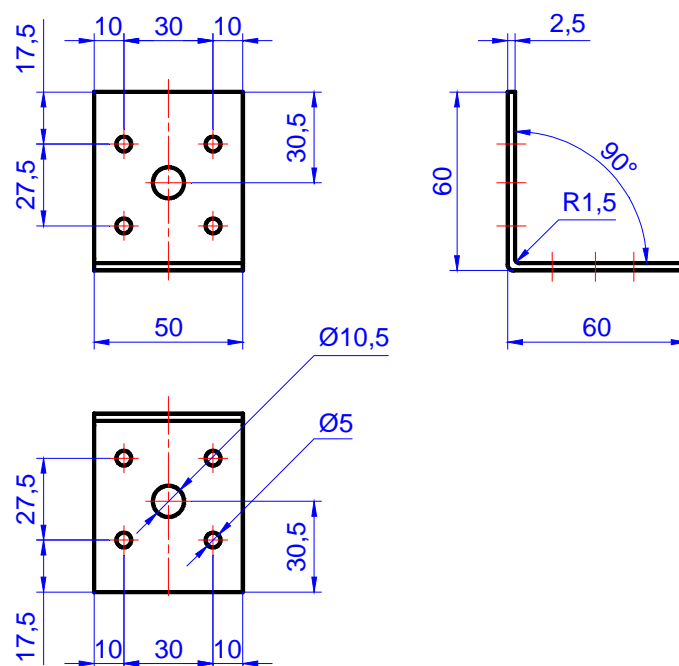




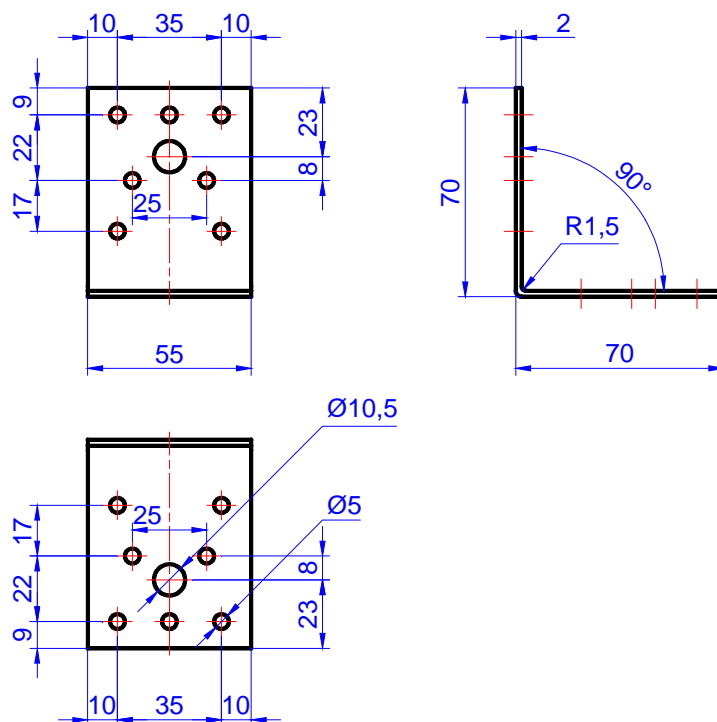
**Figure C.25.** Angle bracket MK 50 x 50 x 50 x 2,0



**Figure C.26.** Angle bracket MK 60 x 60 x 50 x 2,0



**Figure C.27.** Angle bracket MK 60 x 60 x 50 x 2,5



**Figure C.28.** Angle bracket MK 70 x 70 x 55 x 2,0

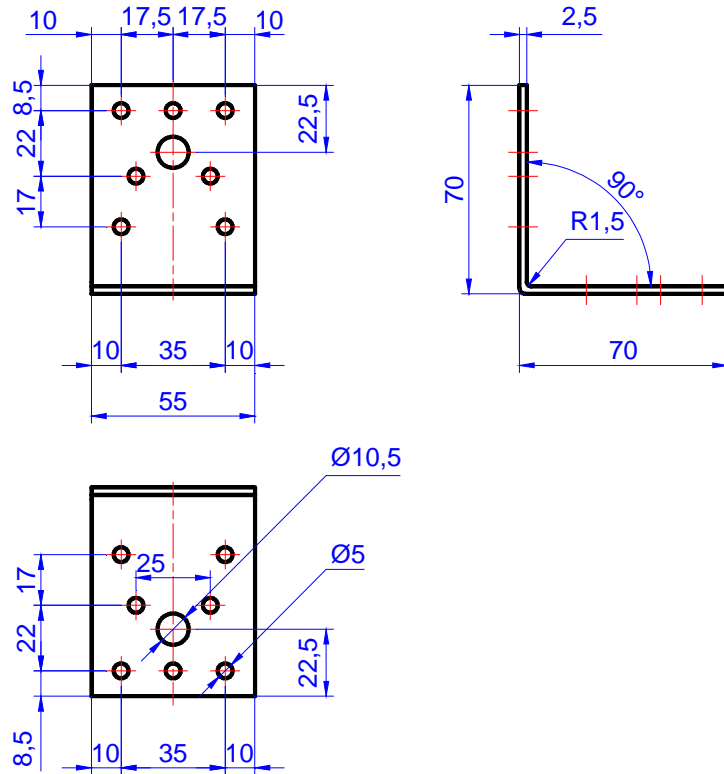


Figure C.29. Angle bracket MK 70 x 70 x 55 x 2,5

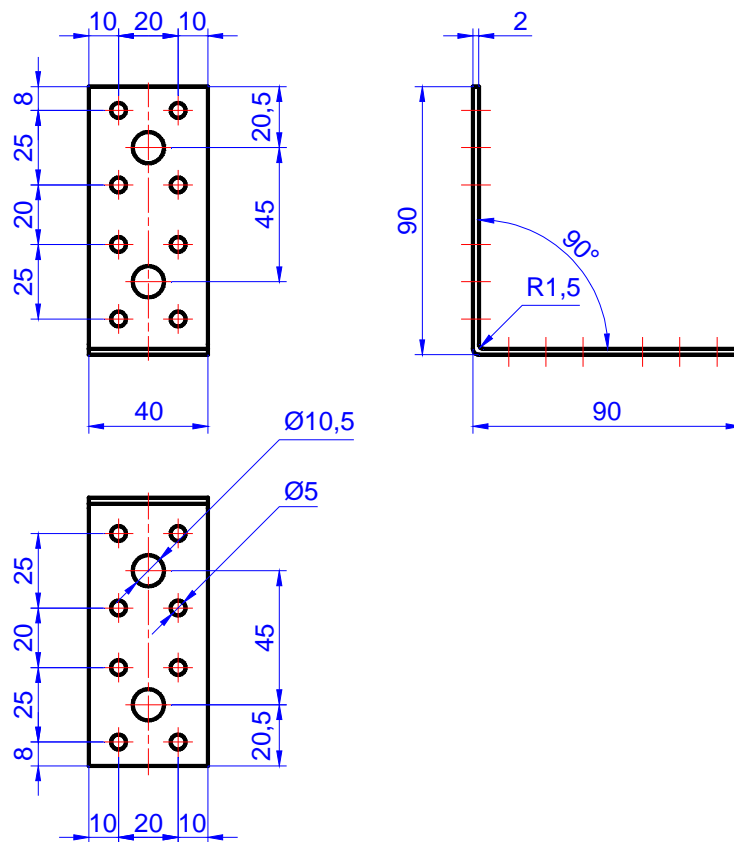


Figure C.30. Angle bracket MK 90 x 90 x 40 x 2,0

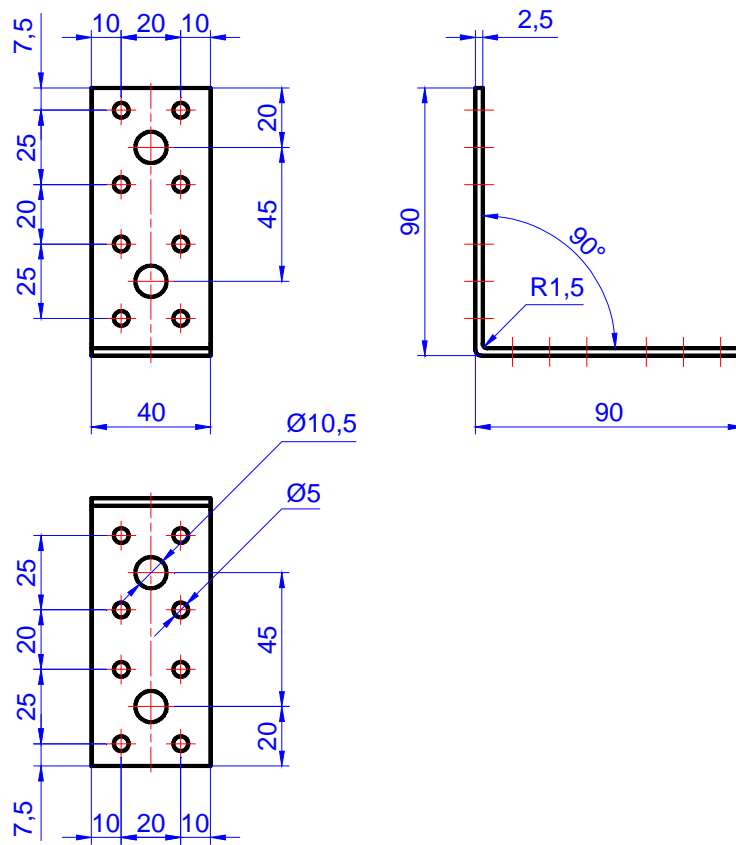


Figure C.31. Angle bracket MK 90 x 90 x 40 x 2,5

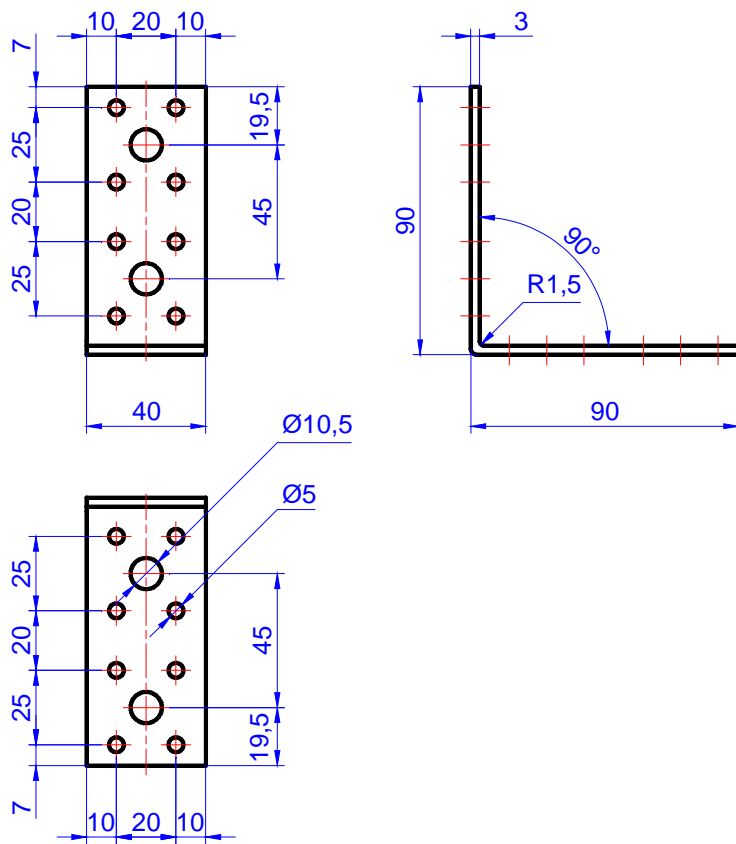
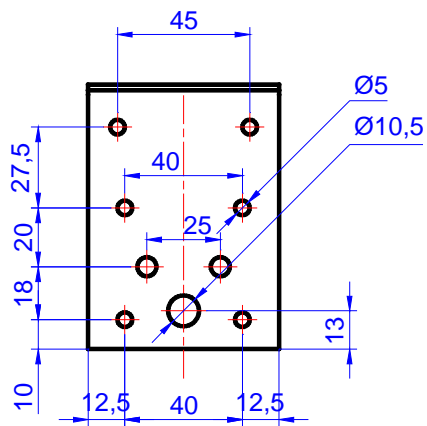
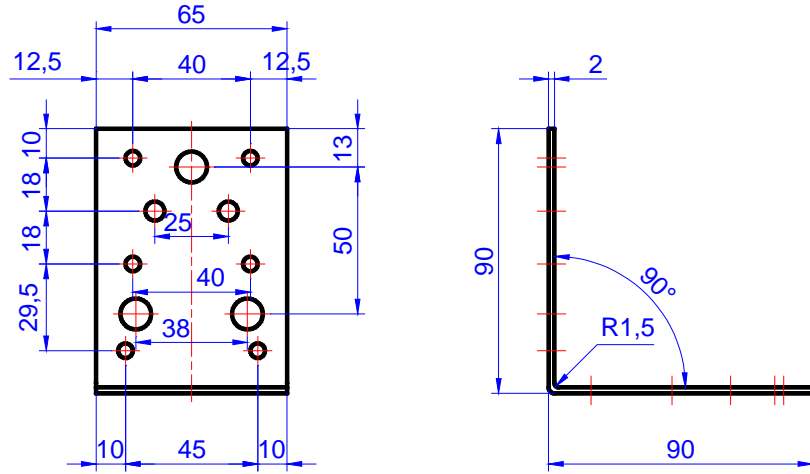
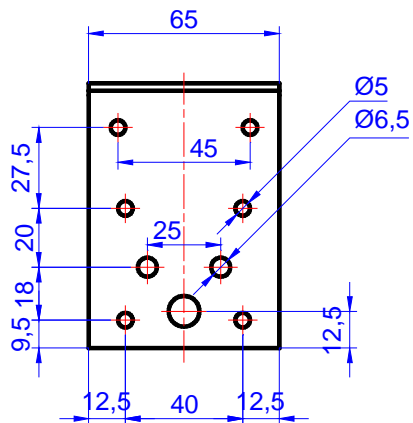
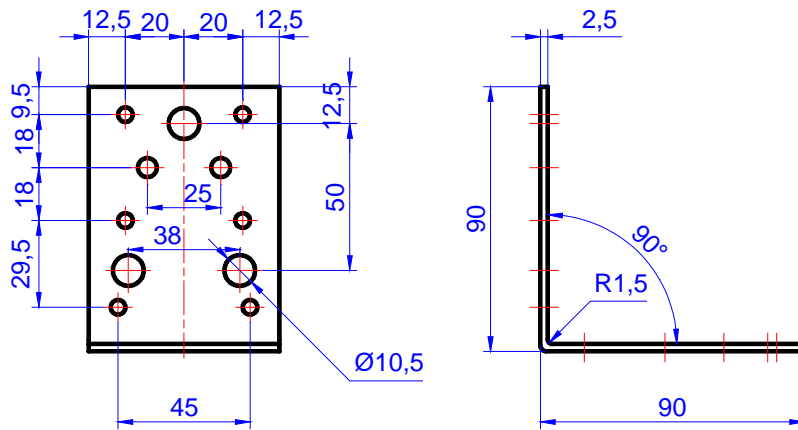


Figure C.32. Angle bracket MK 90x90x40x3,0



**Figure C.33.** Angle bracket MK 90 x 90 x 65 x 2,0



**Figure C.34.** Angle bracket MK 90 x 90 x 65 x 2,5

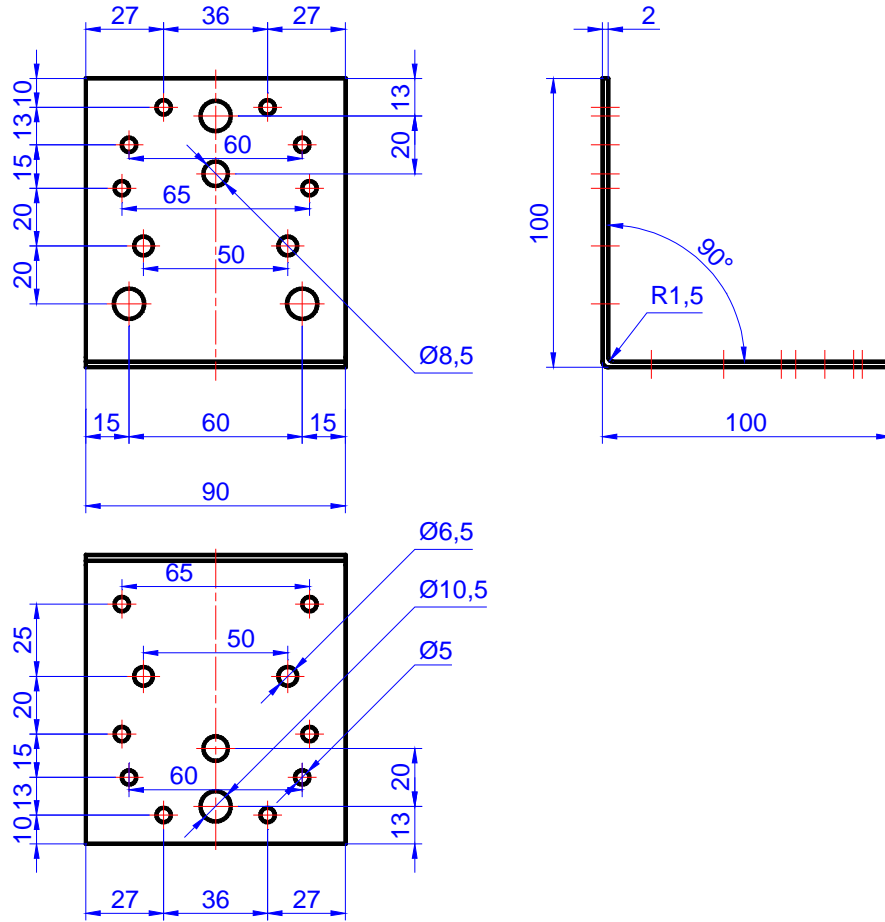


Figure C.35. Angle bracket MK 100 x 100 x 90 x 2,0

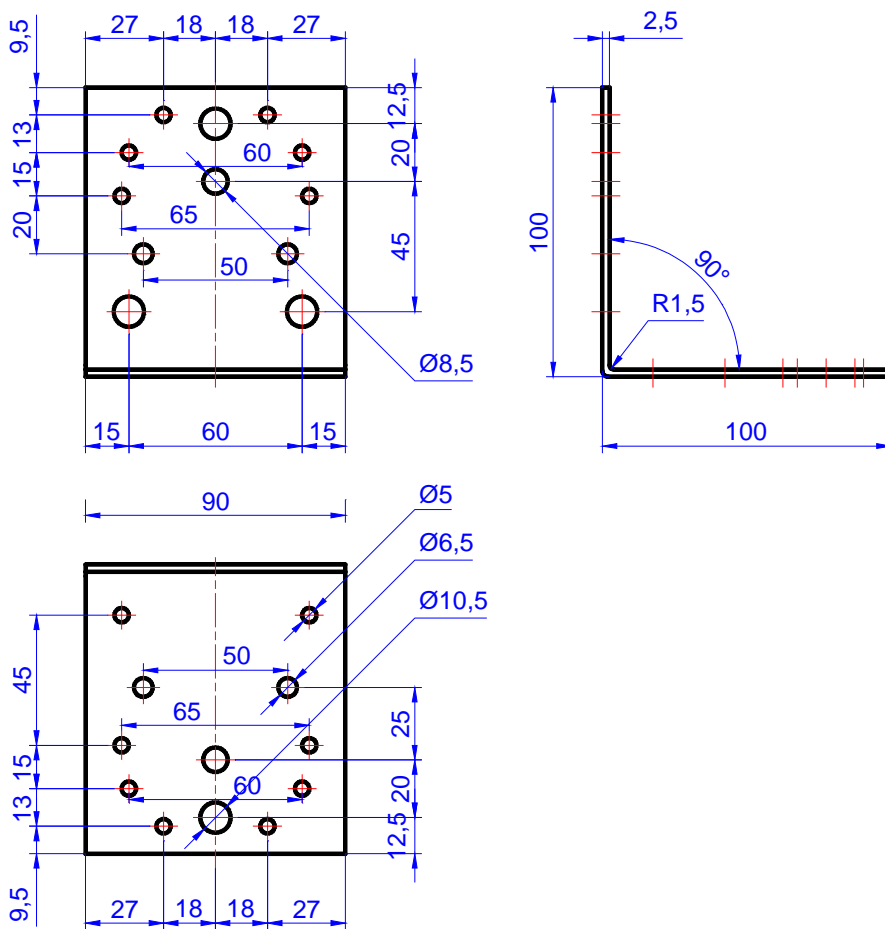
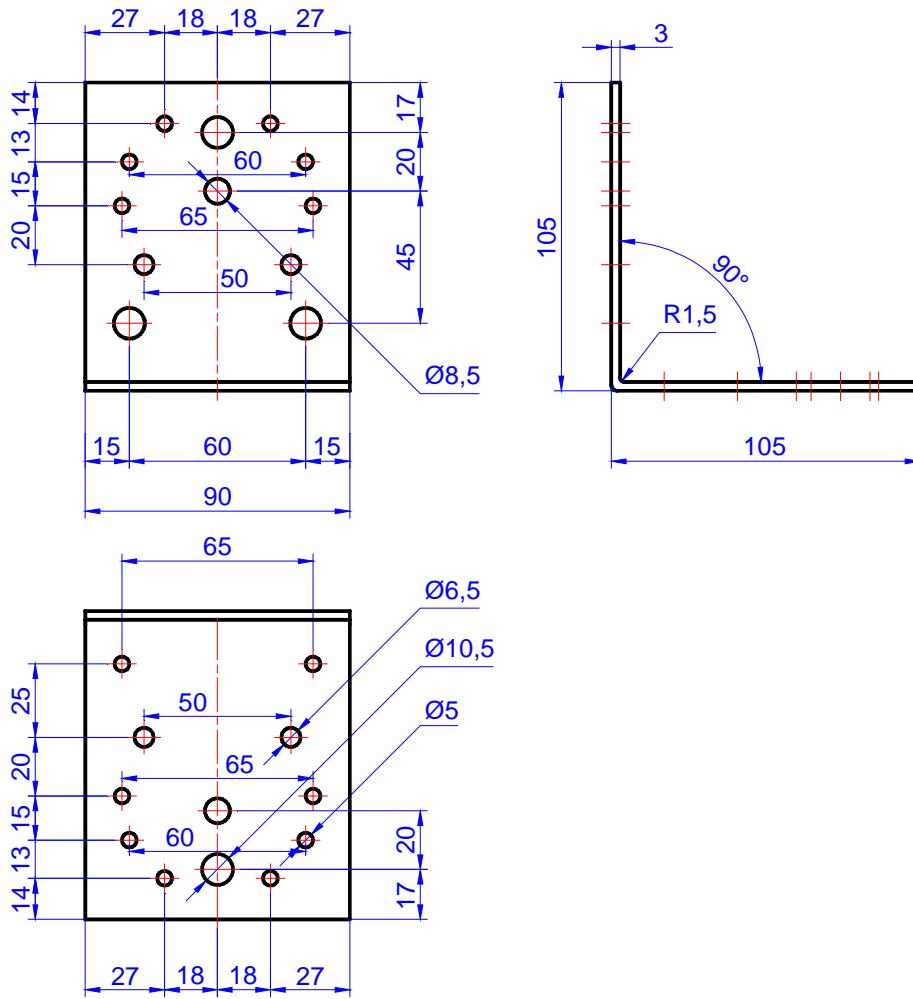
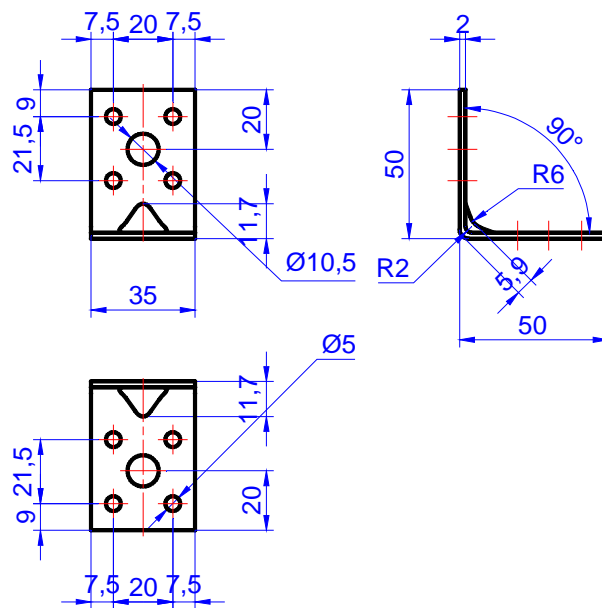


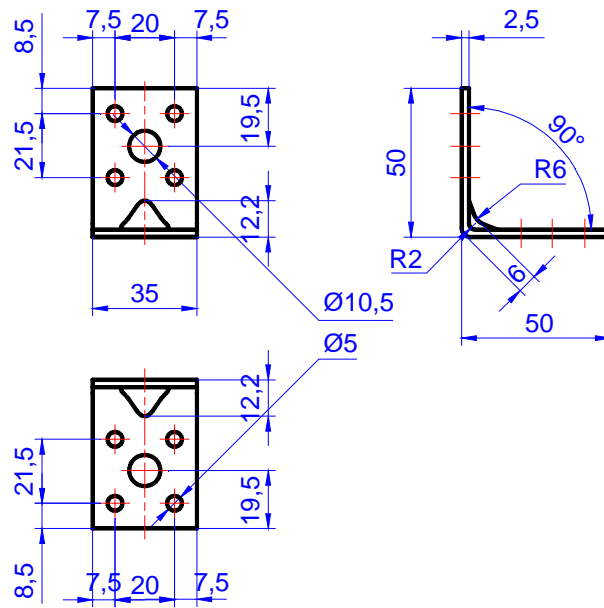
Figure C.36. Angle bracket MK 100 x 100 x 90 x 2,5



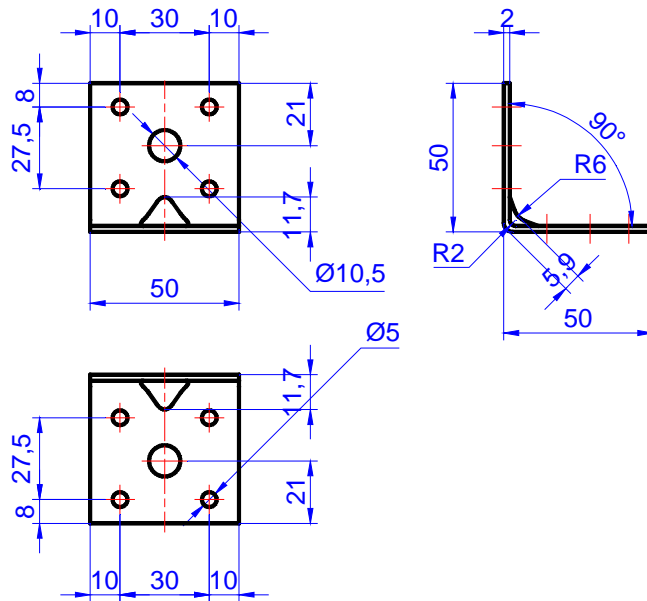
**Figure C.37.** Angle bracket MK 105 × 105 × 90 × 3,0



**Figure C.38.** Angle bracket MKS 50 × 50 × 35 × 2,0



**Figure C.39.** Angle bracket MKS 50 × 50 × 35 × 2,5



**Figure C.40.** Angle bracket MKS 50 × 50 × 50 × 2,0



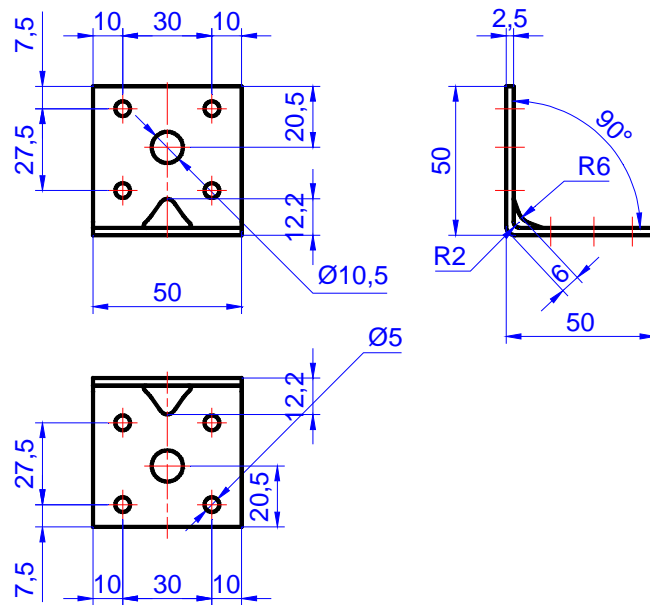


Figure C.41. Angle bracket MKS 50 × 50 × 50 × 2,5

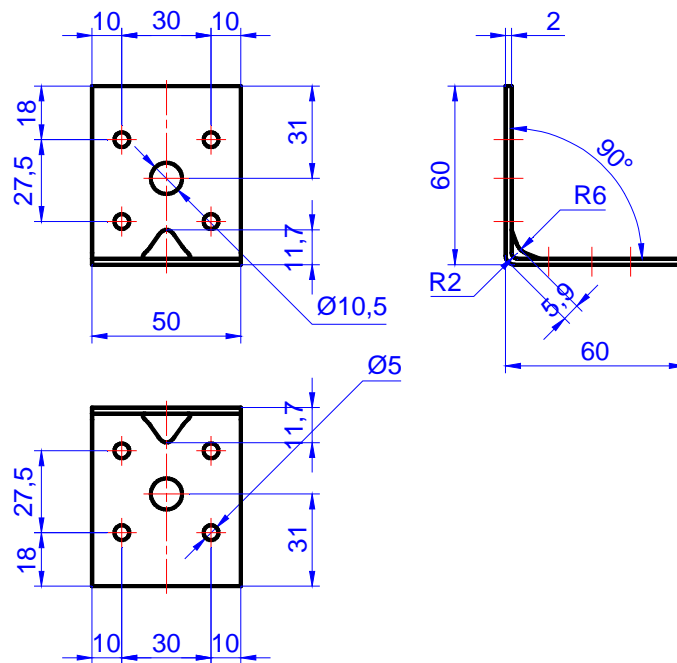


Figure C.42. Angle bracket MKS 60 × 60 × 50 × 2,0

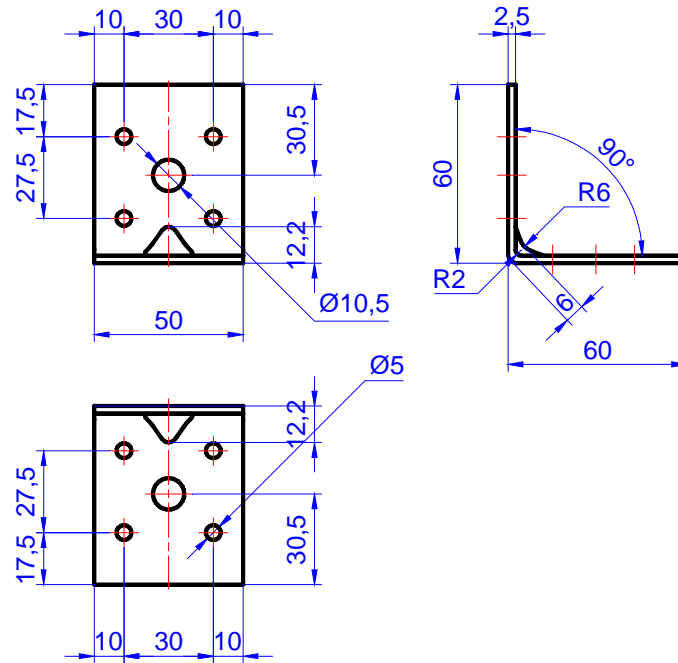


Figure C.43. Angle bracket MKS 60 × 60 × 50 × 2,5

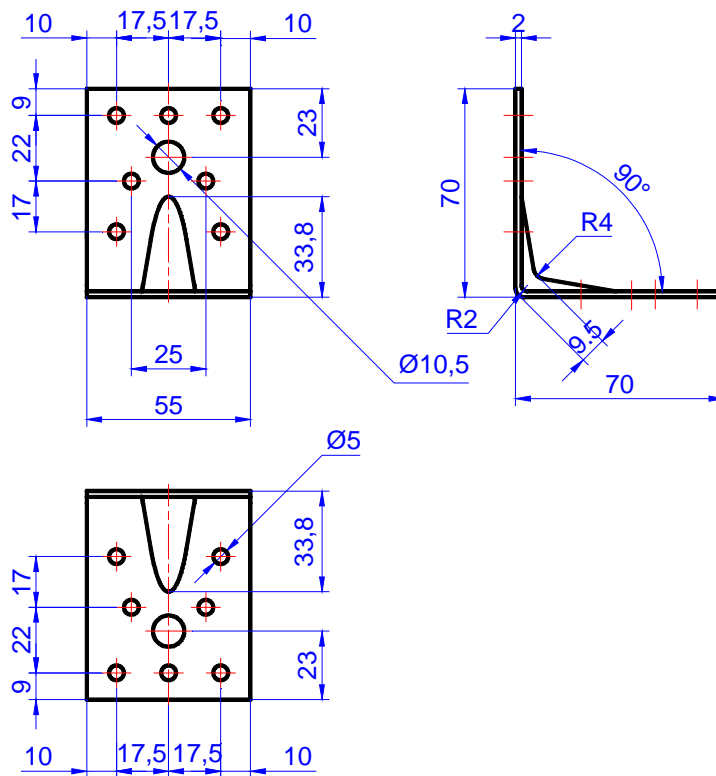
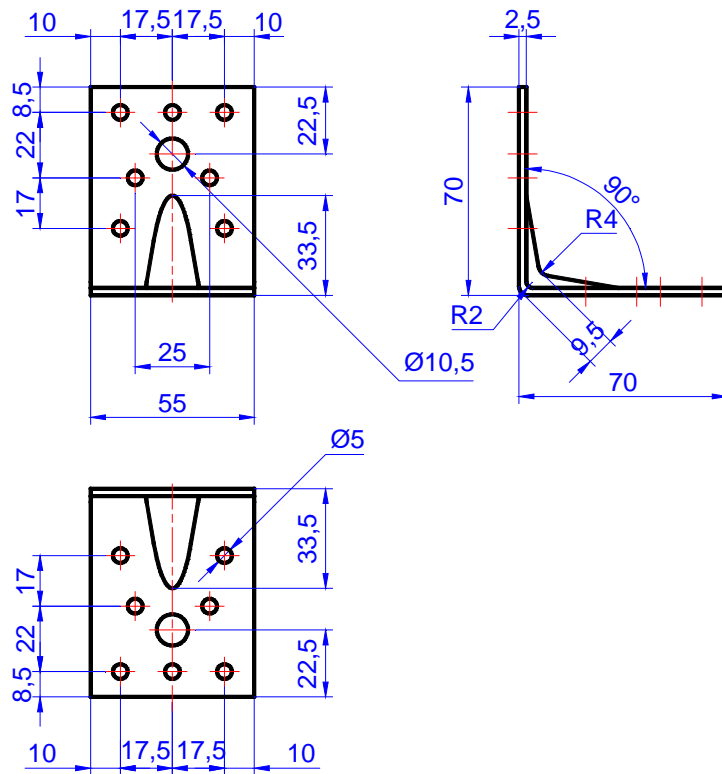
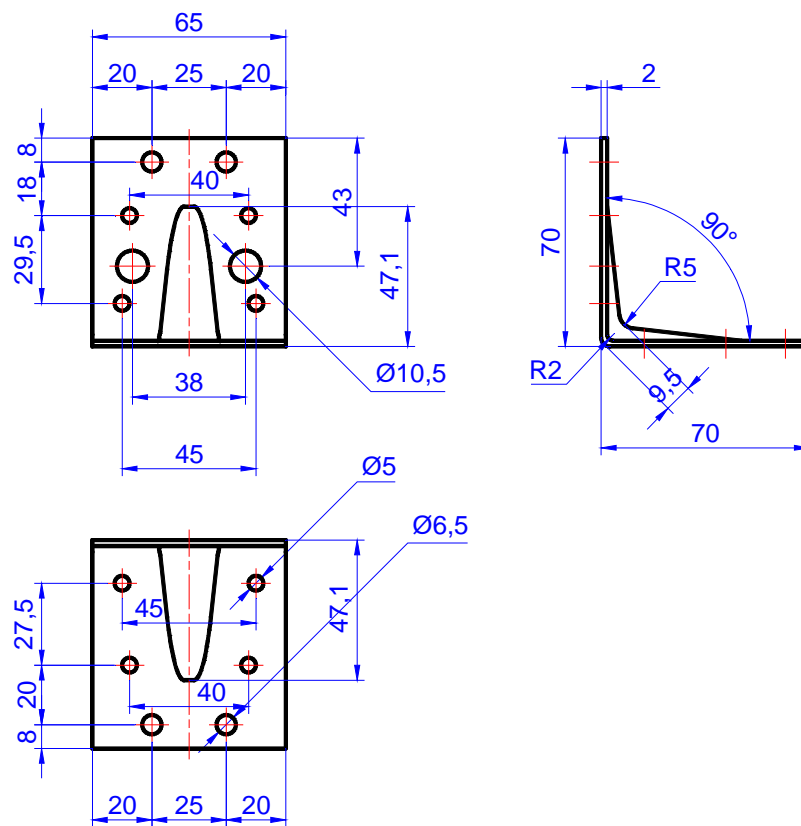


Figure C.44. Angle bracket MKS 70 × 70 × 55 × 2,0



**Figure C.45.** Angle bracket MKS 70 × 70 × 55 × 2,5



**Figure C.46.** Angle bracket MKS 70 × 70 × 65 × 2,0

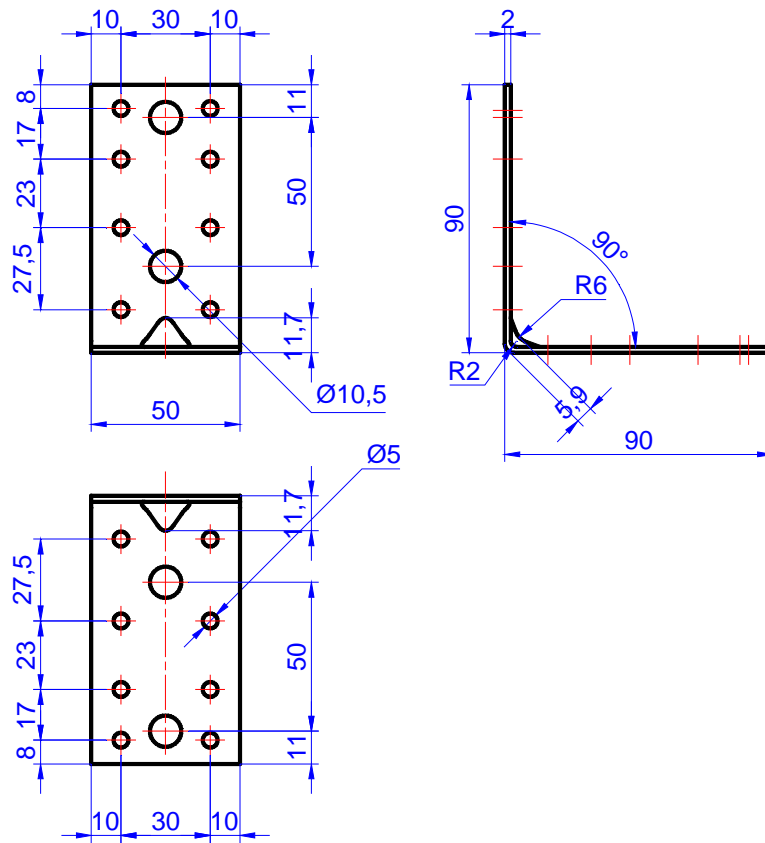


Figure C.47. Angle bracket MKS 90 x 90 x 50 x 2,0

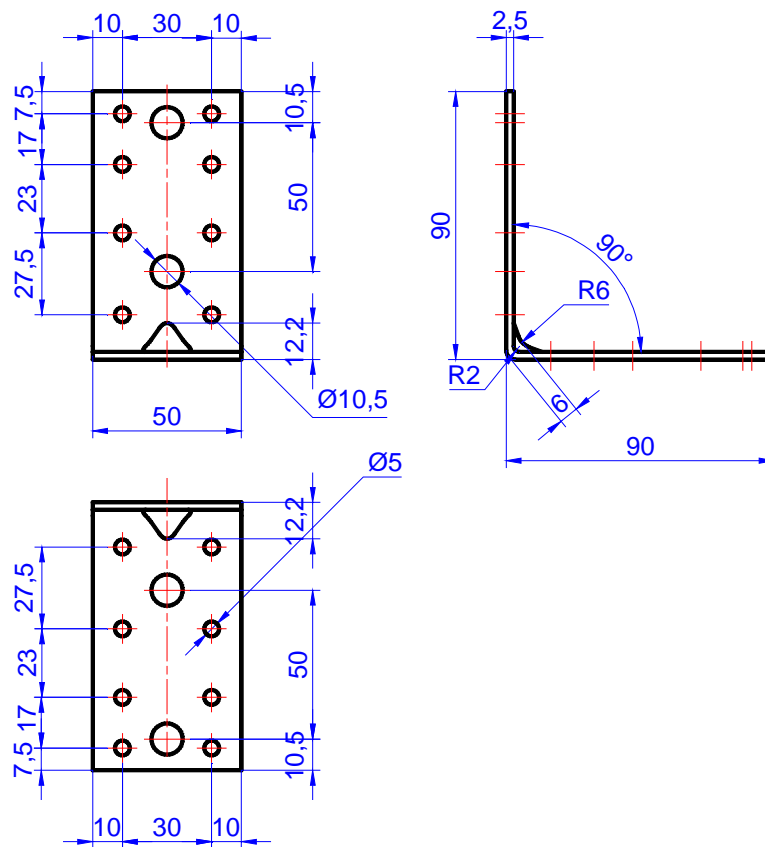
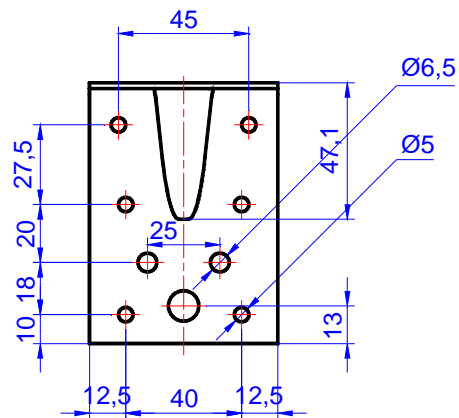
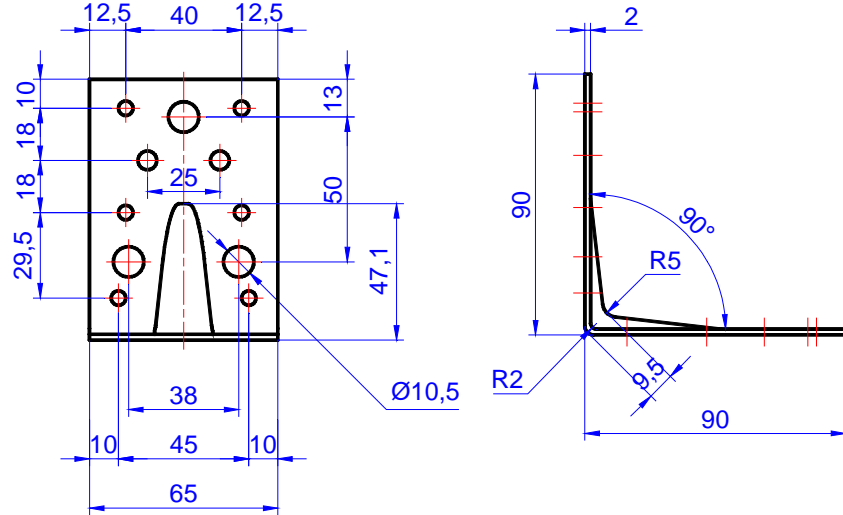
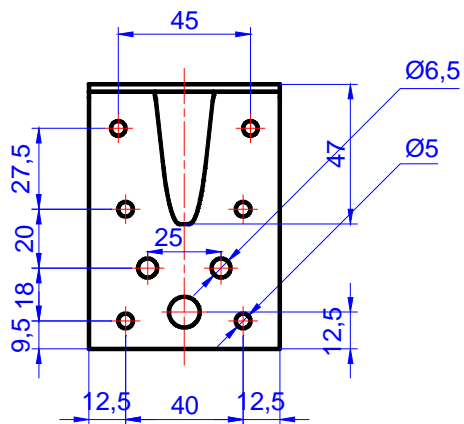
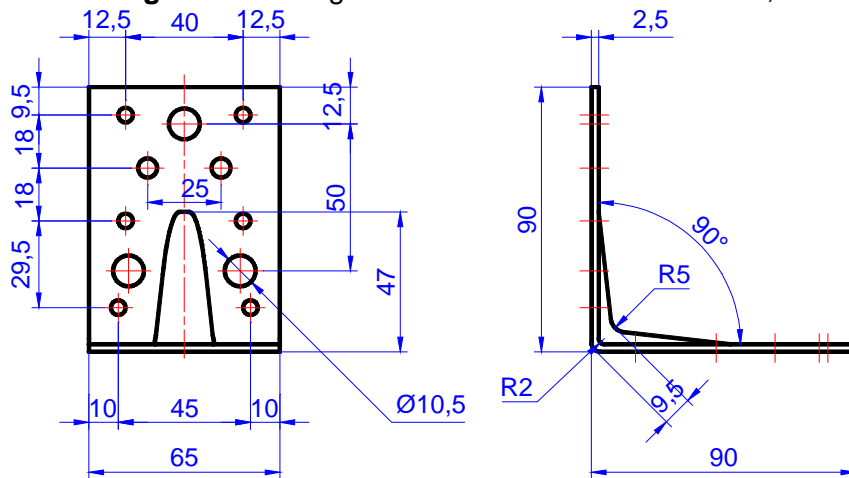


Figure C.48. Angle bracket MKS 90 x 90 x 50 x 2,5



**Figure C.49.** Angle bracket MKS 90 x 90 x 65 x 2,0



**Figure C.50.** Angle bracket MKS 90 x 90 x 65 x 2,5

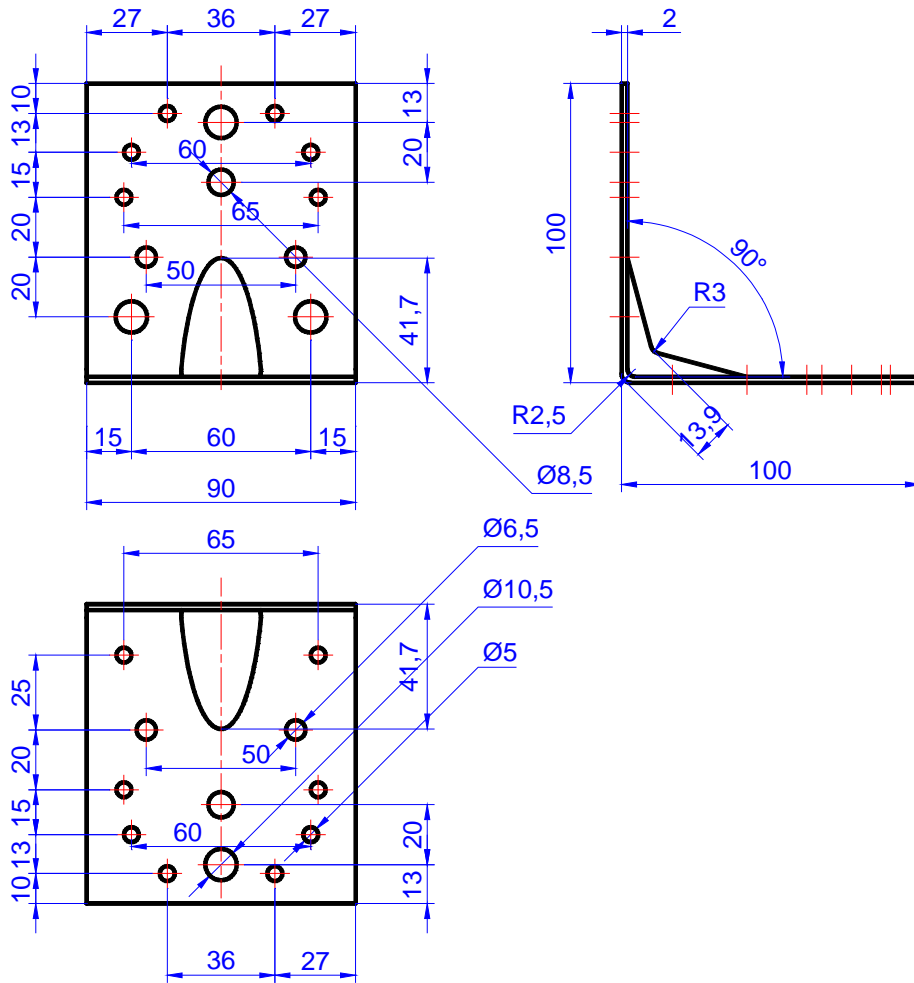


Figure C.51. Angle bracket MKS 100 x 100 x 90 x 2,0

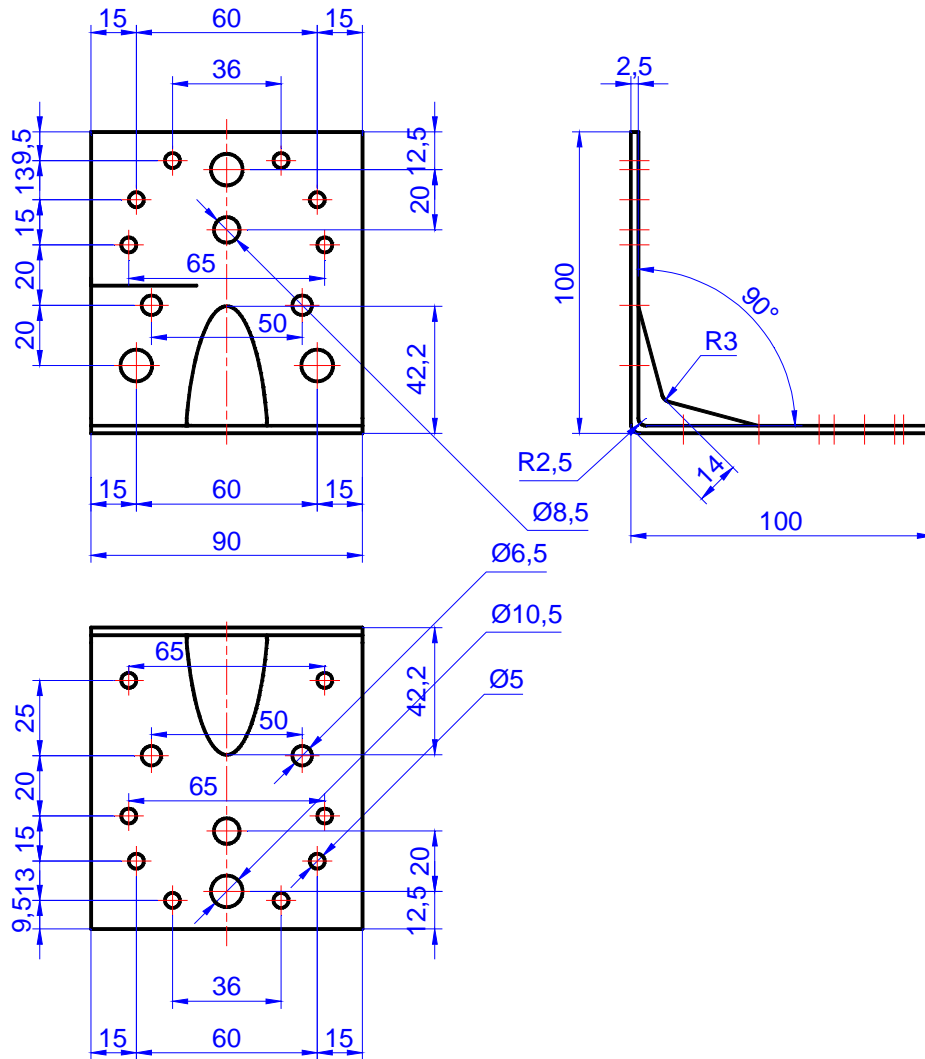


Figure C.52. Angle bracket MKS 100 x 100 x 90 x 2,5

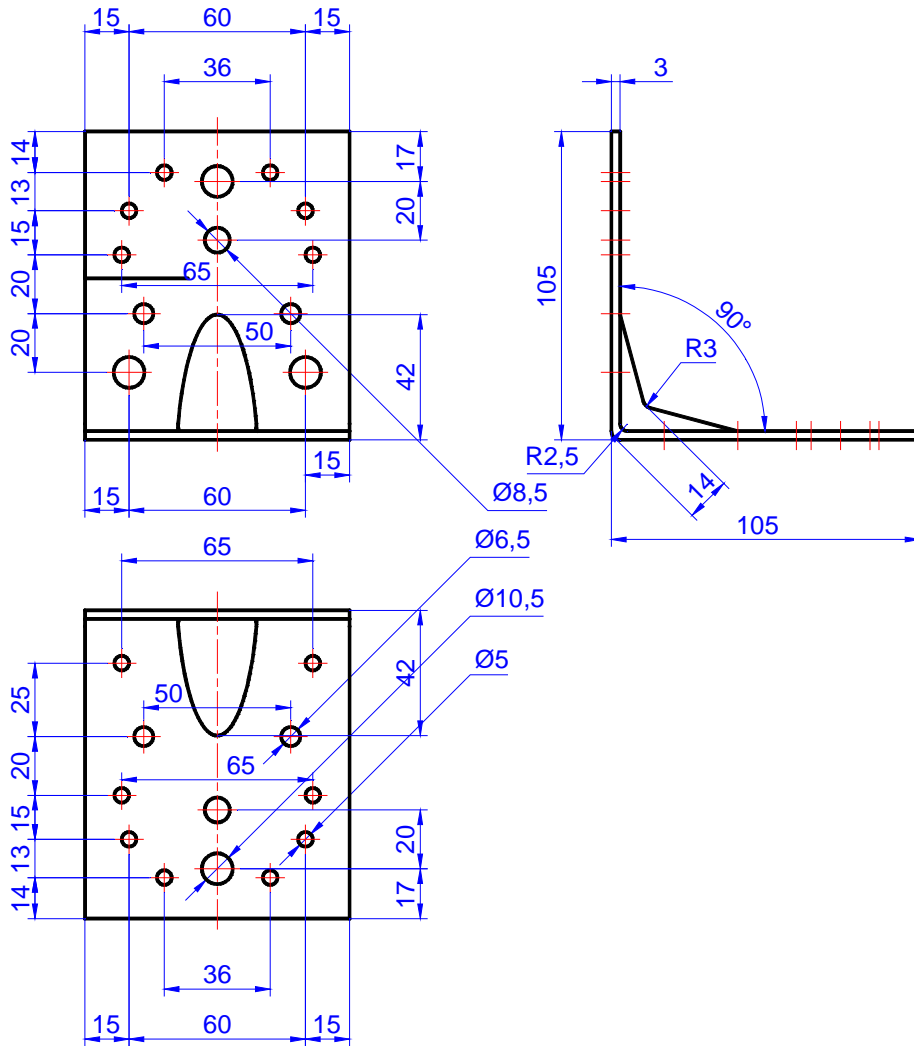


Figure C.53. Angle bracket MKS 105 × 105 × 90 × 3,0

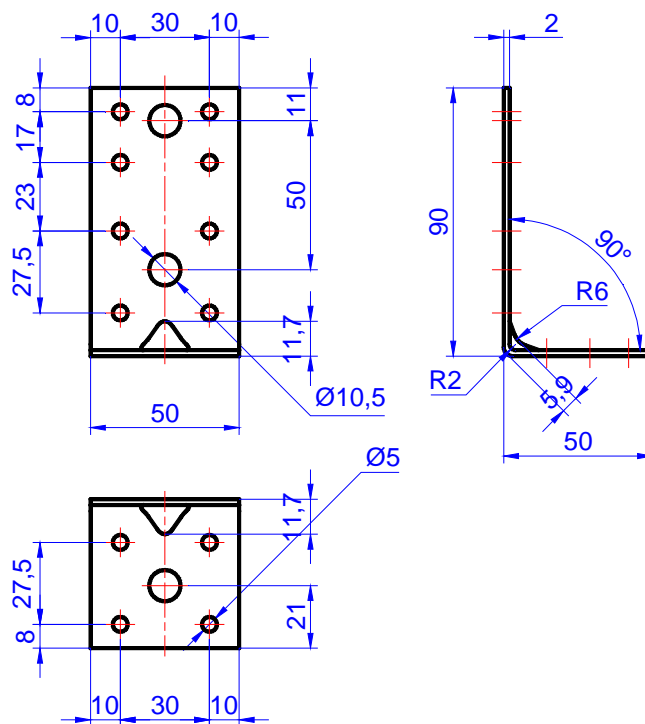


Figure C.54. Angle bracket MKNS 90 × 50 × 50 × 2,0



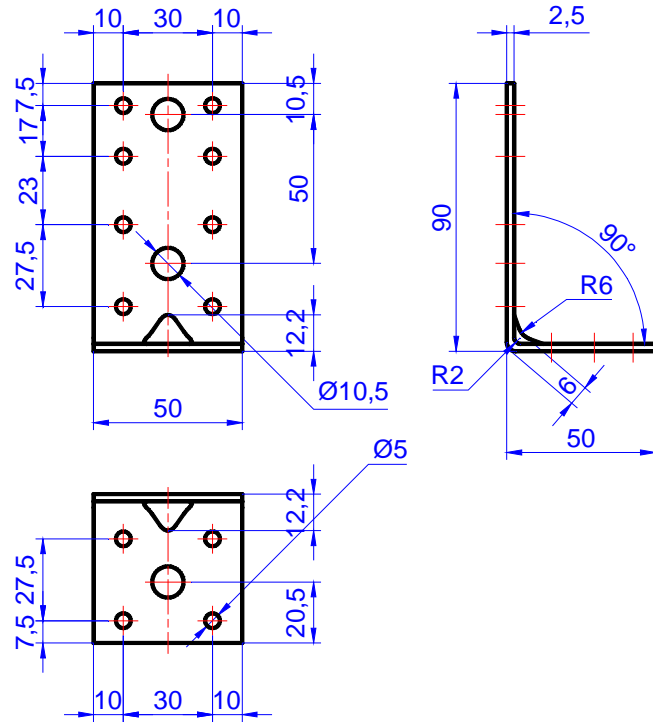


Figure C.55. Angle bracket MKNS90 x 50 x 50 x 2,5

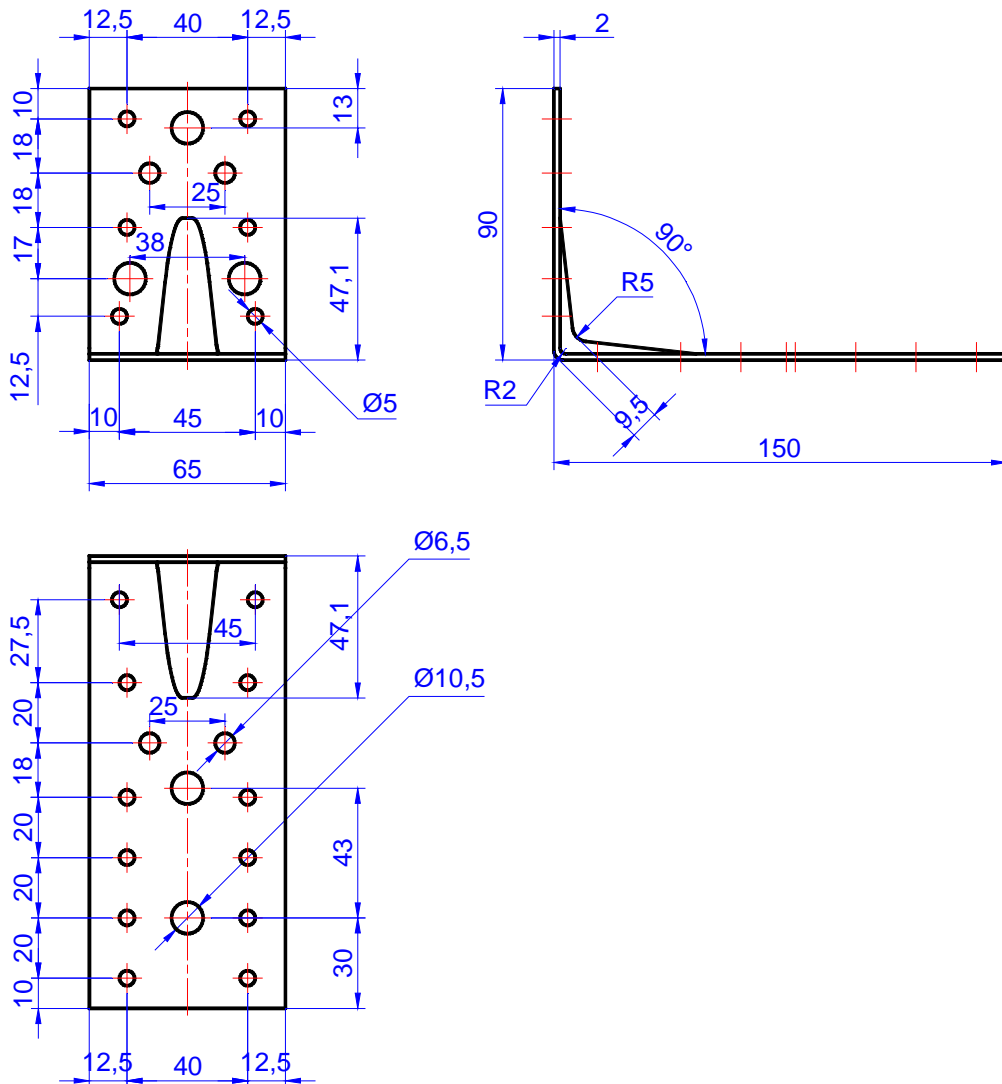
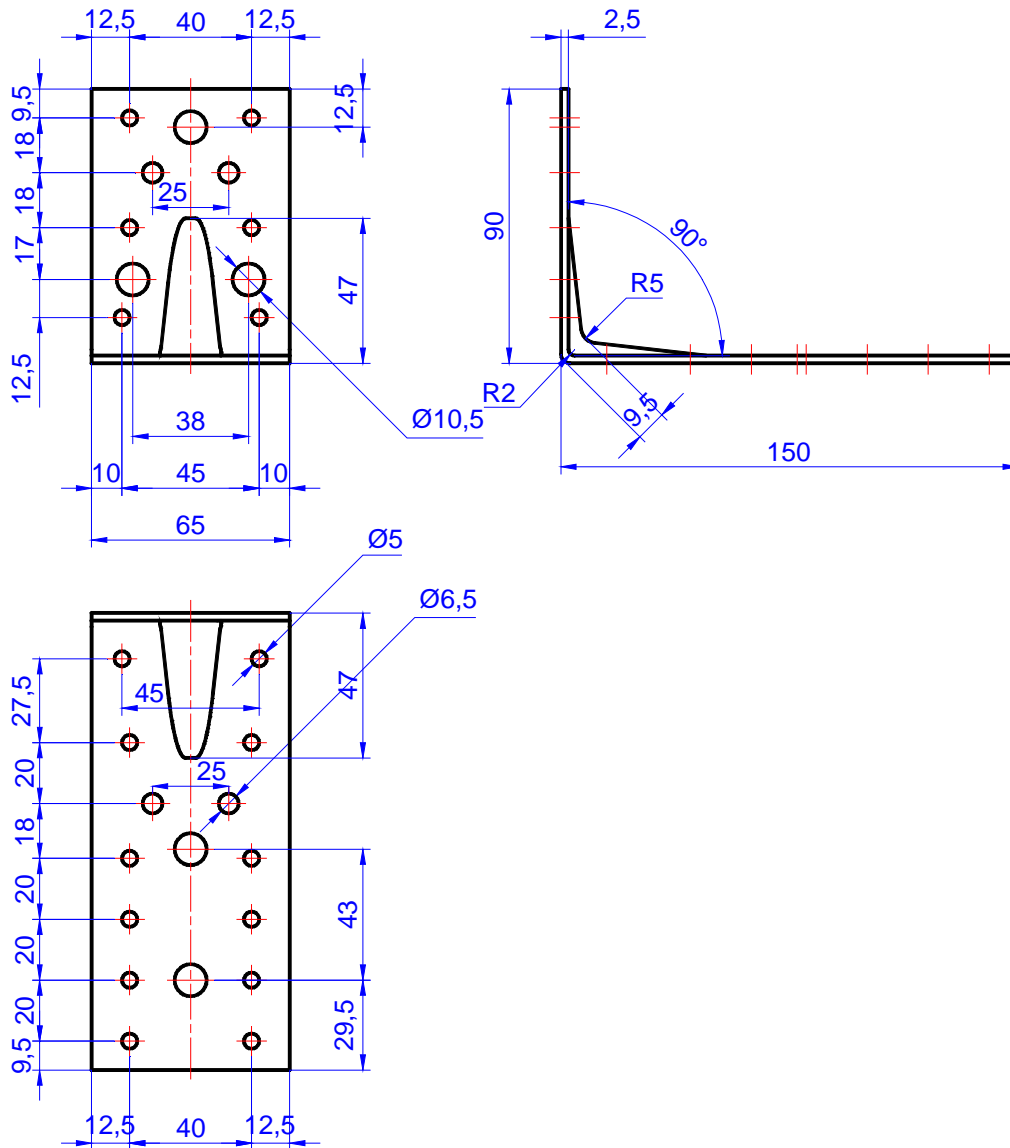


Figure C.56. Angle bracket MKNS 150 x 90 x 65 x 2,0



**Figure C.57.** Angle bracket MKNS 150 × 90 × 65 × 2,5

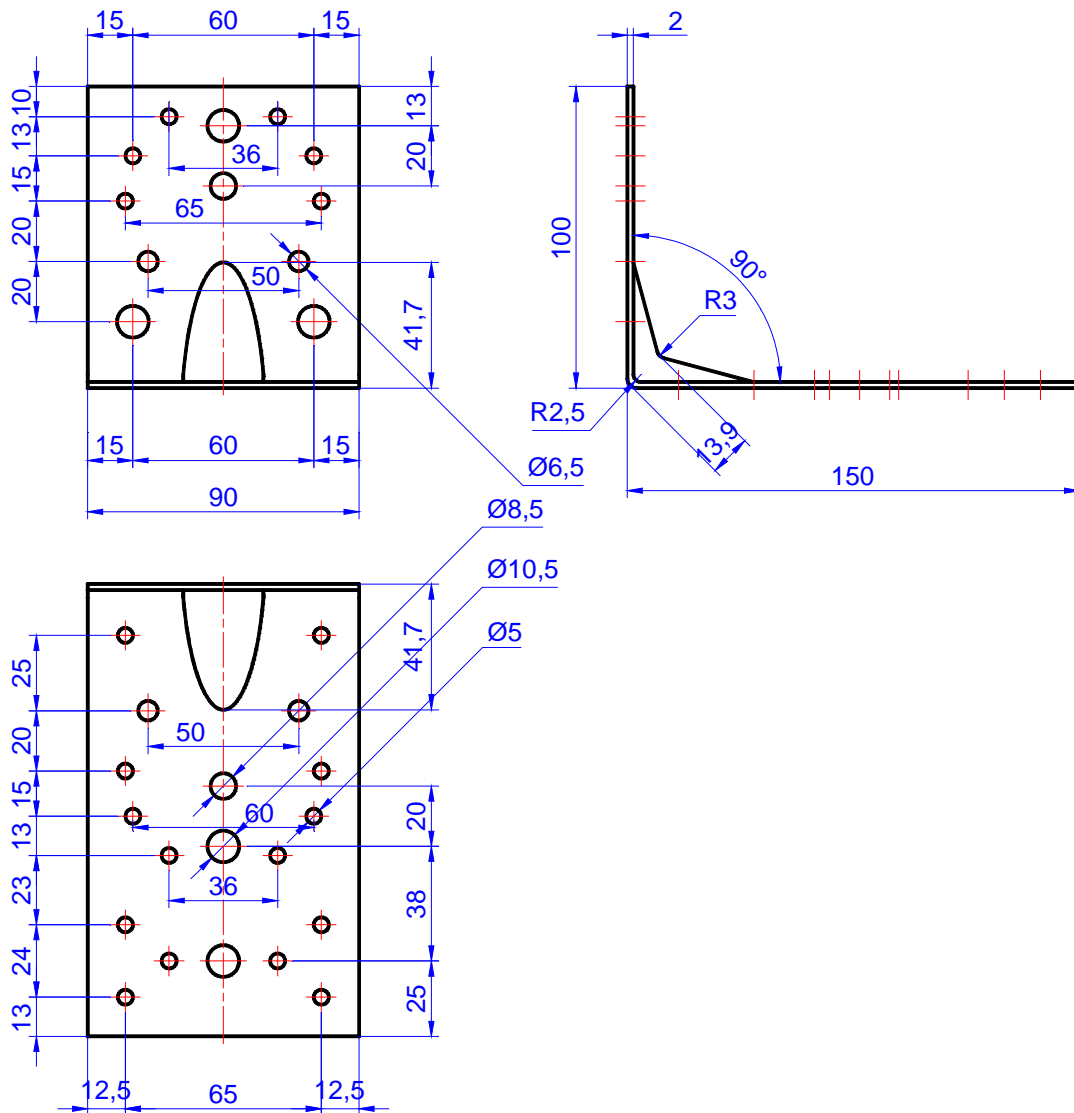


Figure C.58. Angle bracket MKNS 150 x 100 x 90 x 2,0

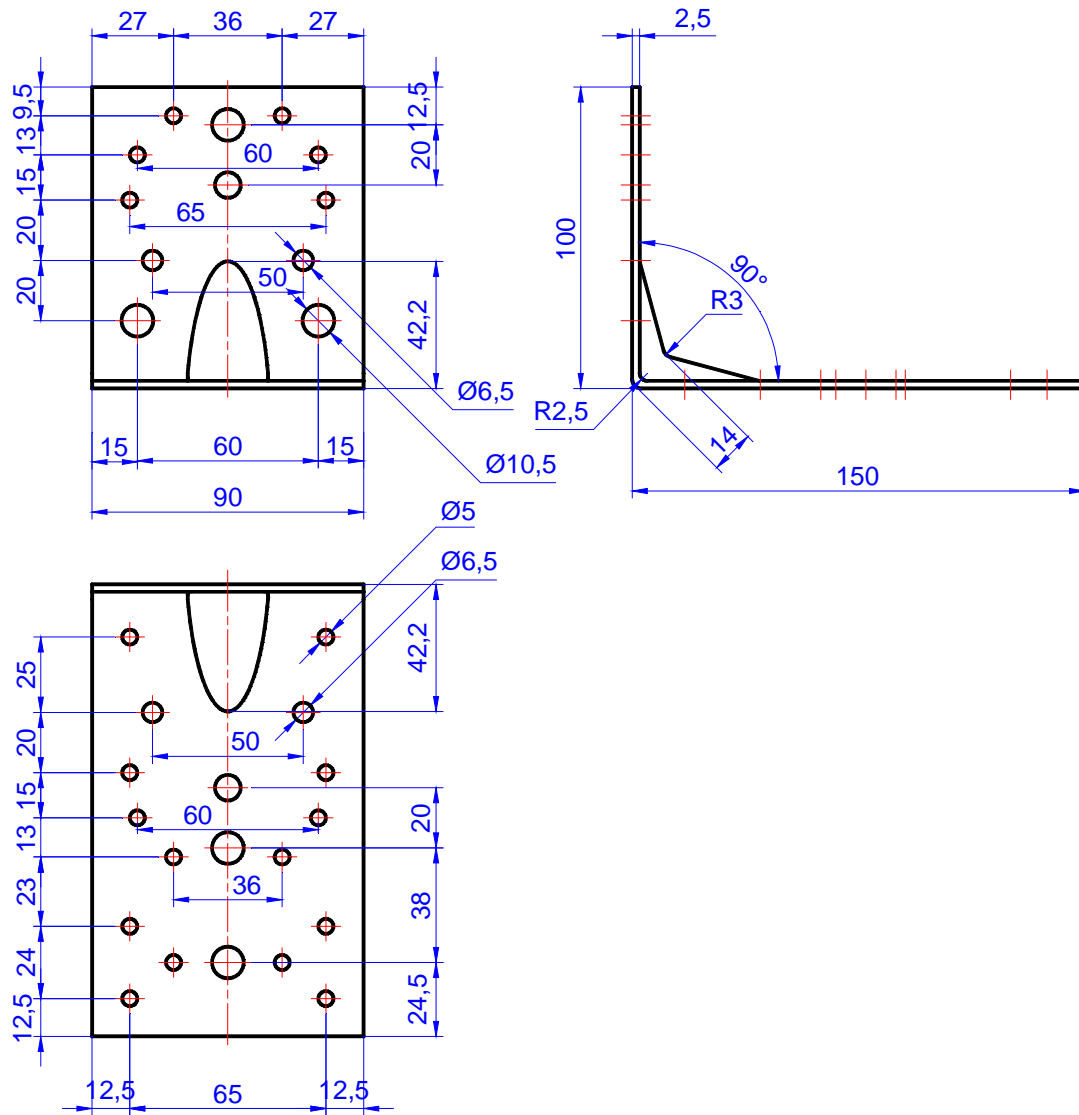


Figure C.59. Angle bracket MKNS 150 x 100 x 90 x 2,5

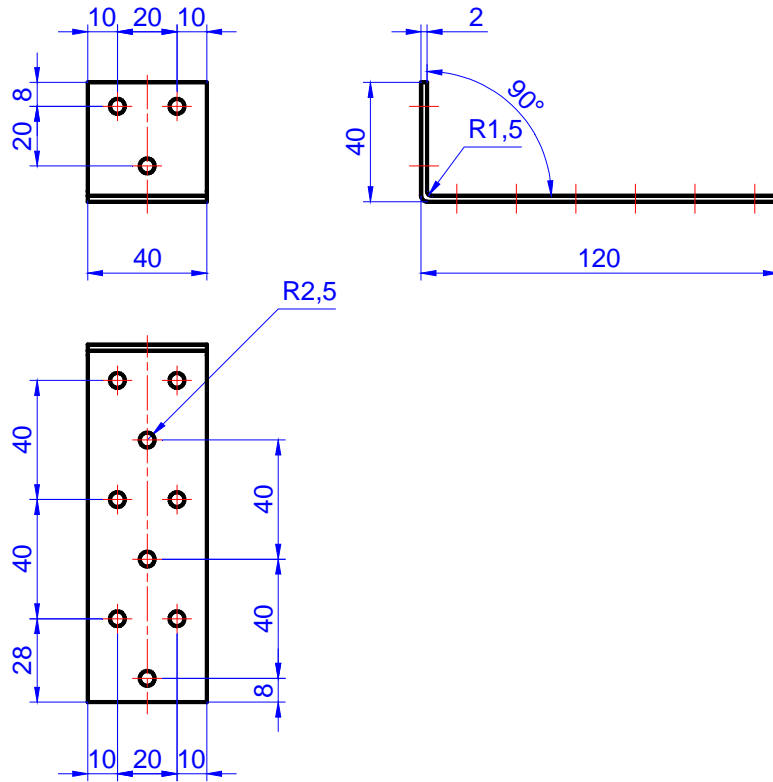


Figure C.60. Angle bracket MKN 120 x 40 x 40 x 2,0

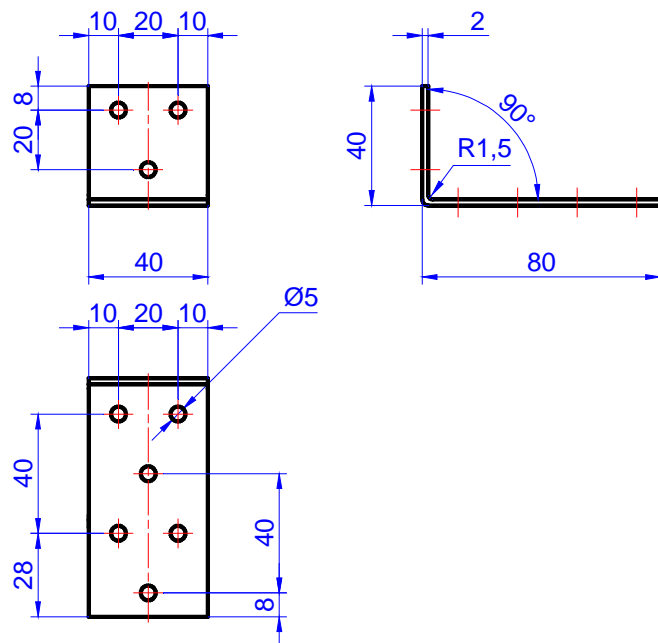


Figure C.61. Angle bracket MKN 80 x 40 x 40 x 2,0

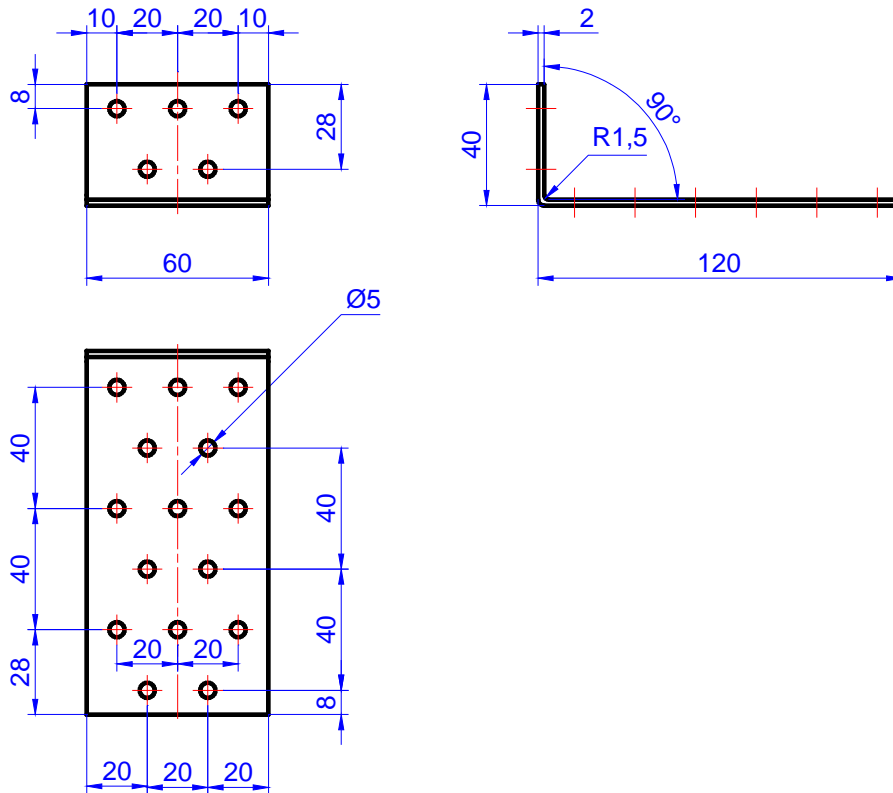


Figure C.62. Angle bracket MKN 120 x 40 x 60 x 2,0

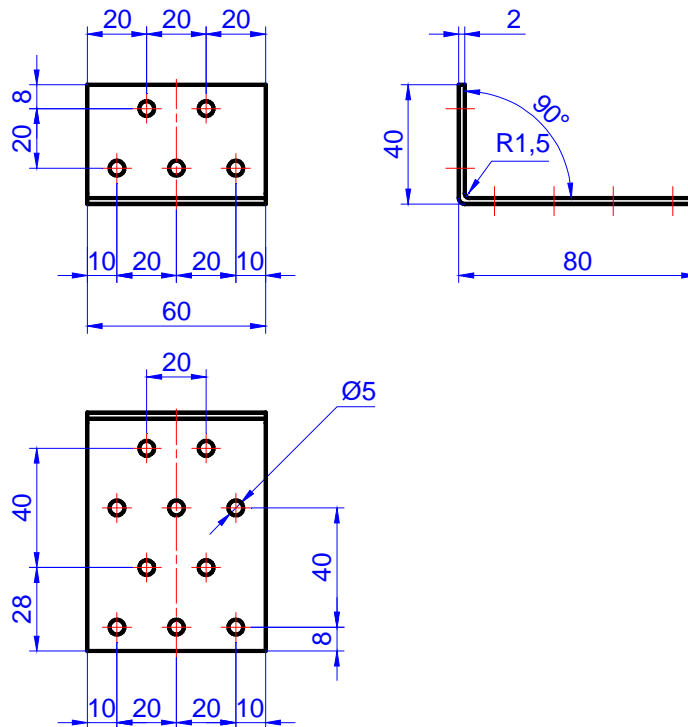
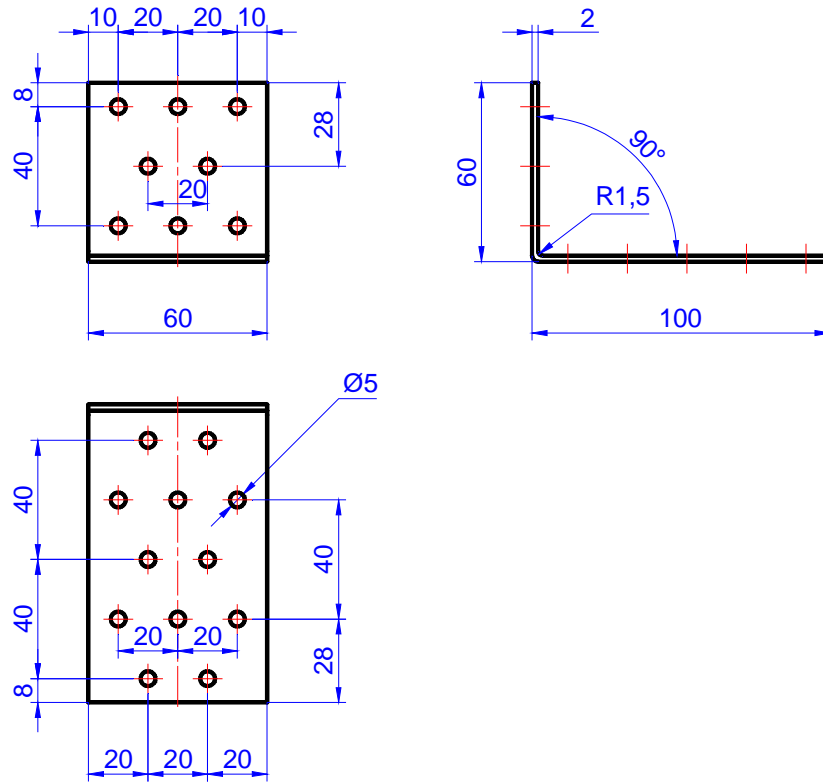


Figure C.63. Angle bracket MKN 80 x 40 x 60 x 2,0



**Figure C.64.** Angle bracket MKN 100 × 60 × 60 × 2,0

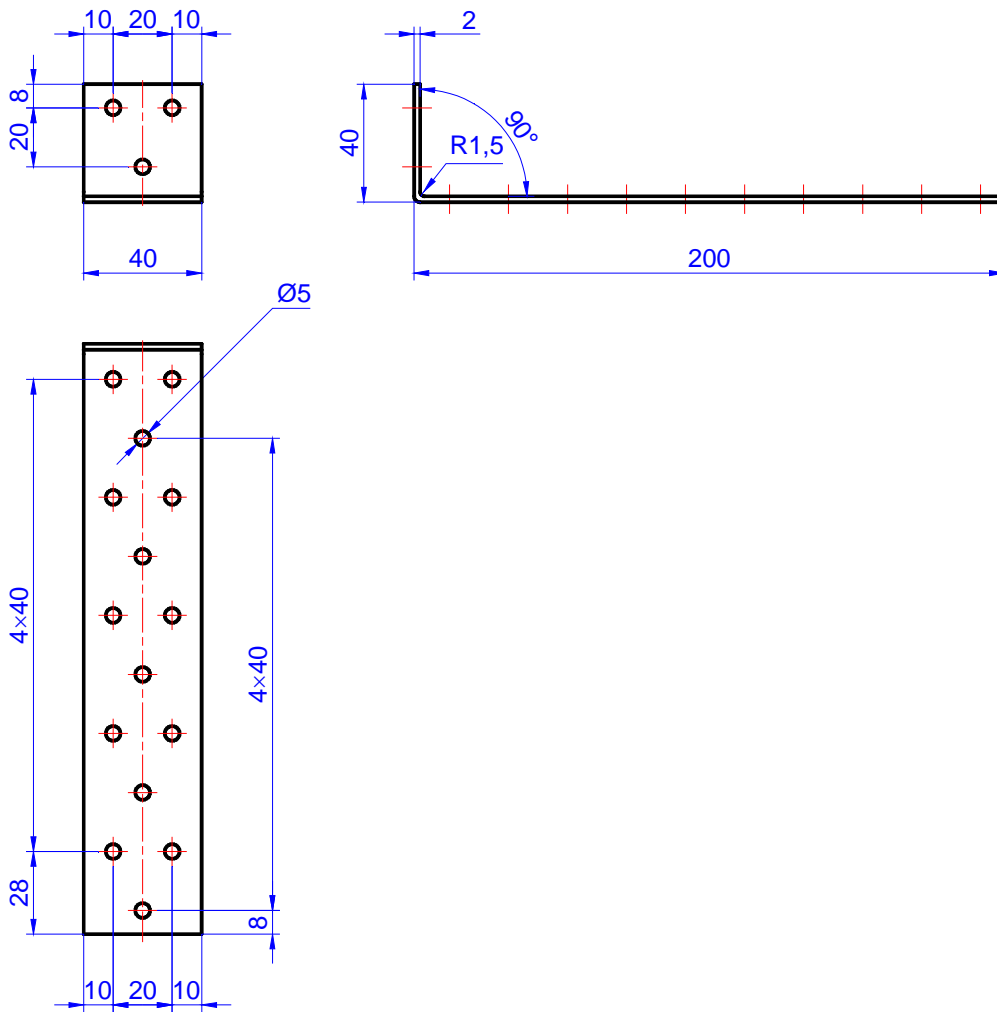


Figure C.65. Angle bracket MKN 200 x 40 x 40 x 2,0

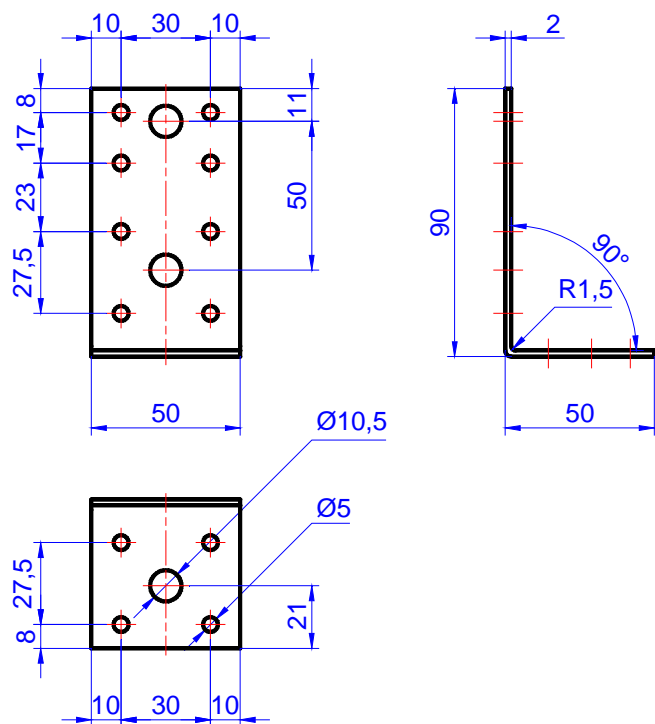
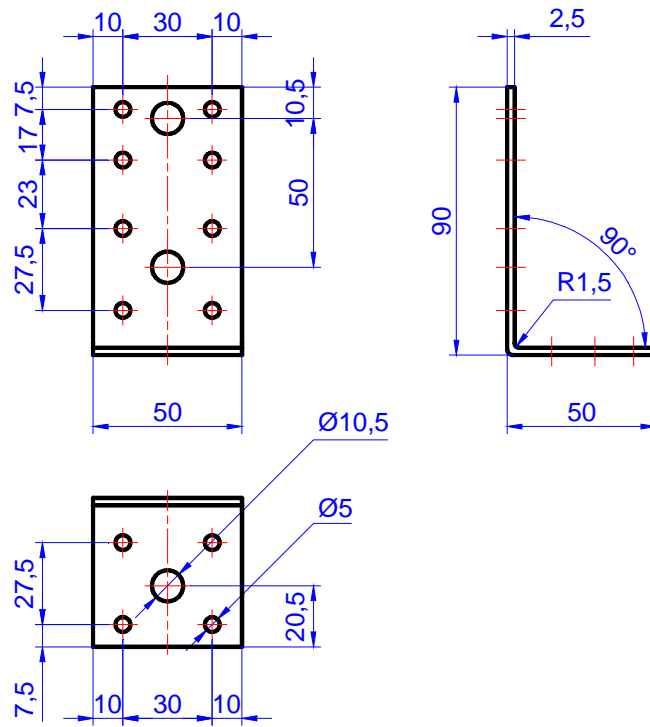
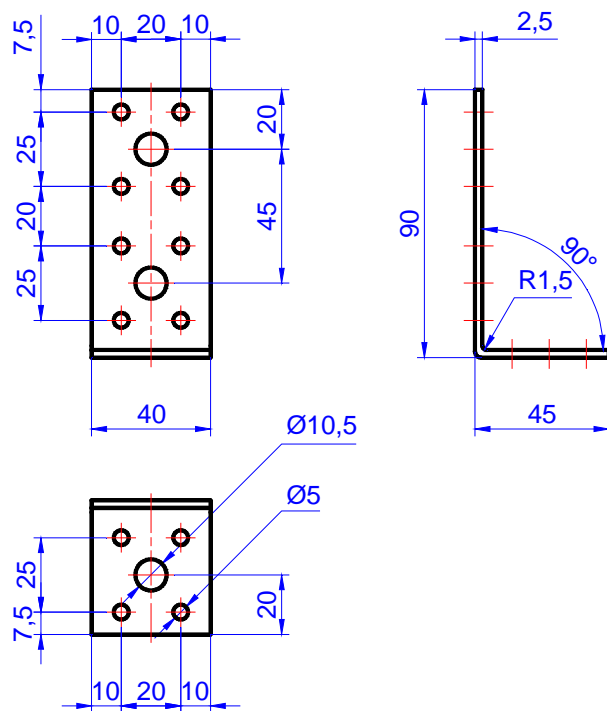


Figure C.66. Angle bracket MKN 90 x 50 x 50 x 2,0





**Figure C.67.** Angle bracket MKN 90 x 50 x 50 x 2,5



**Figure C.68.** Angle bracket MKN 95 x 45 x 40 x 2,5

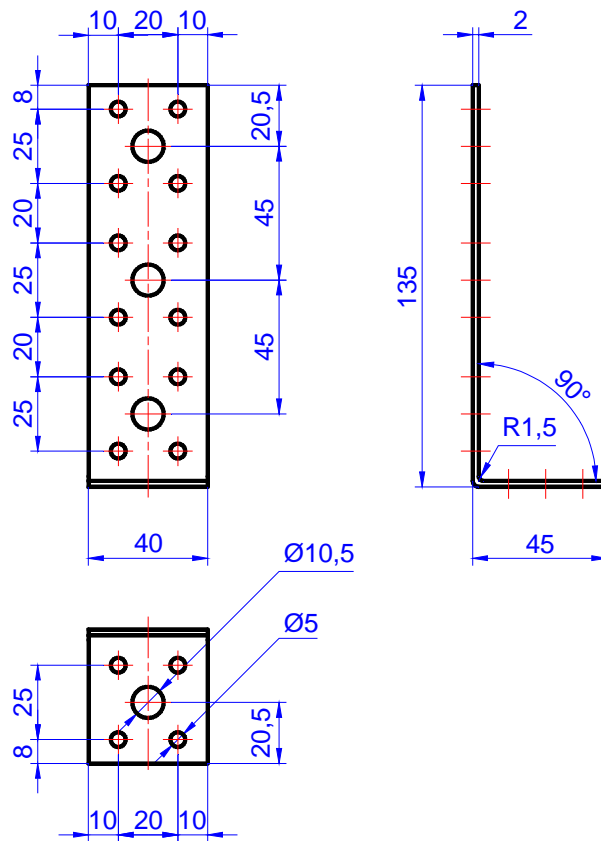


Figure C.69. Angle bracket MKN 135 × 45 × 40 × 2,0

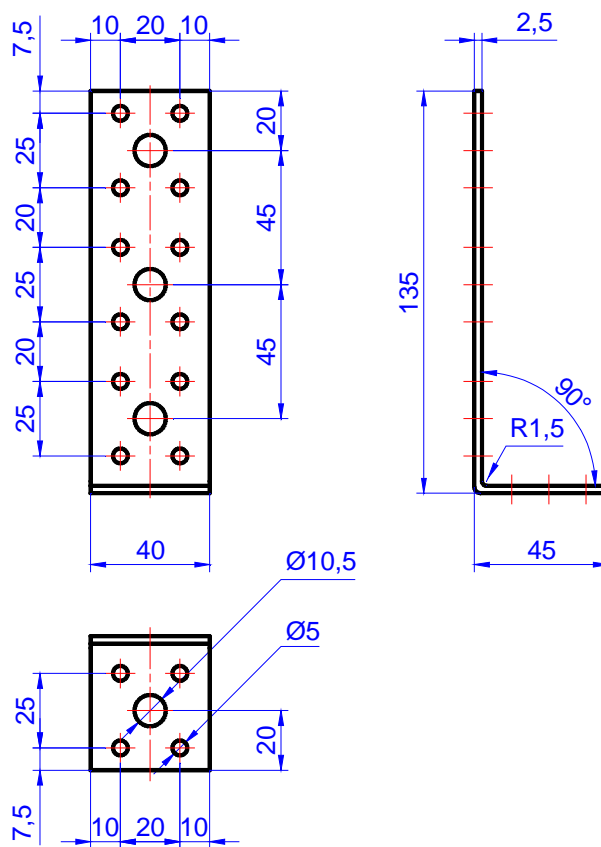
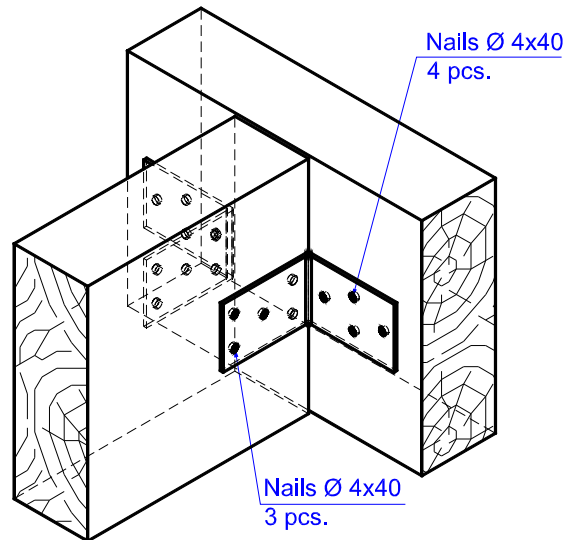


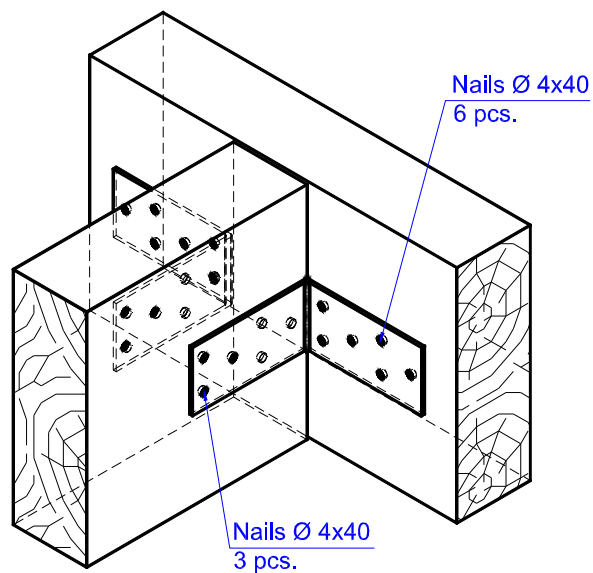
Figure C.70. Angle bracket MKN 135 × 45 × 40 × 2,5

## ANNEX D

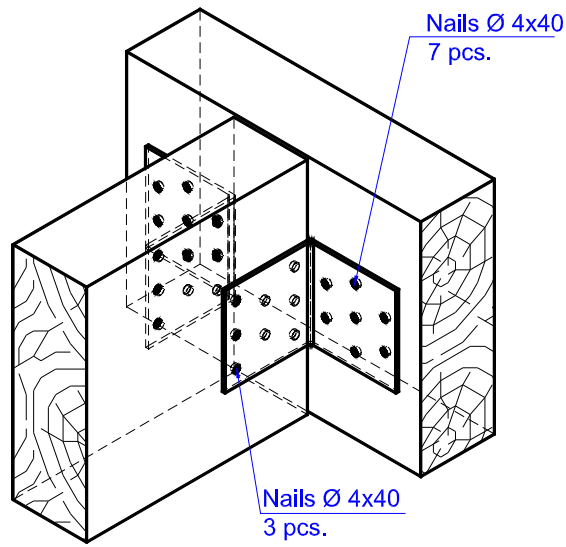
### Number and positions of nails in the angle brackets



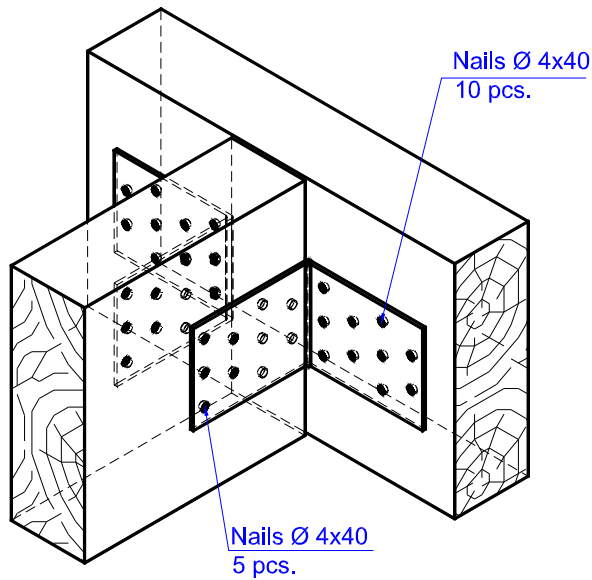
**Figure D.1.** Number and position of nails in the timber beam to timber beam connection with the angle brackets MK 60 × 60 × 40 × 2,0



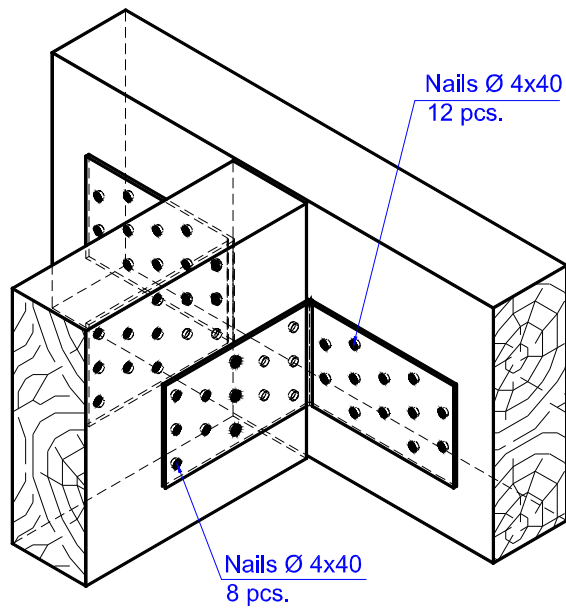
**Figure D.2.** Number and position of nails in the timber beam to timber beam connection with the angle brackets MK 80 × 80 × 40 × 2,0



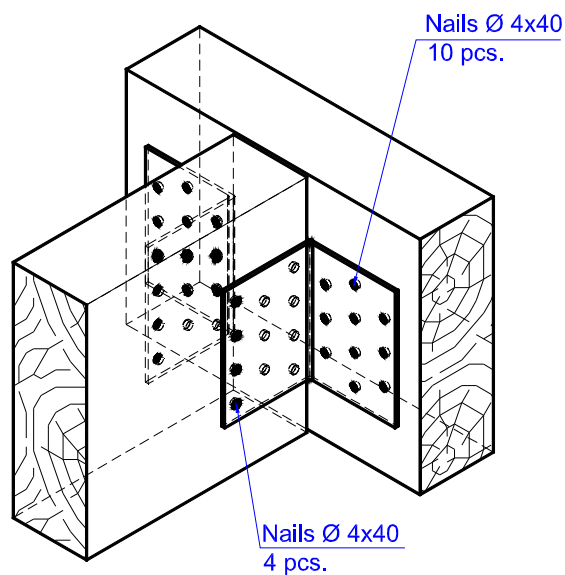
**Figure D.3.** Number and position of nails in the timber beam to timber beam connection with the angle brackets MK 60 × 60 × 60 × 2,0



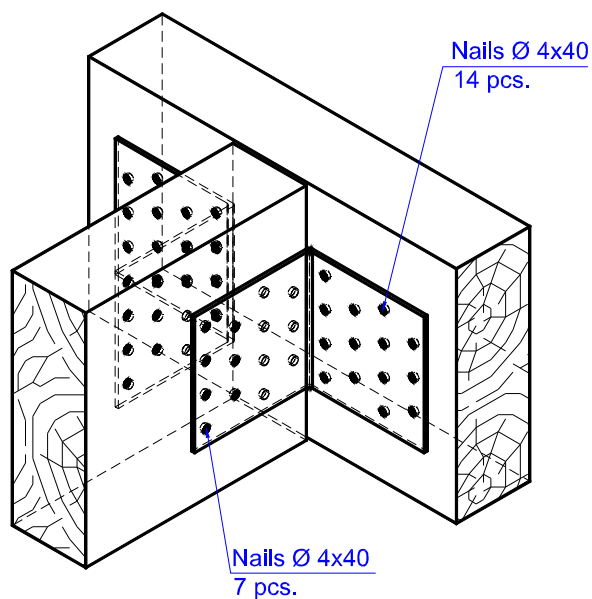
**Figure D.4.** Number and position of nails in the timber beam to timber beam connection with the angle brackets MK 80 × 80 × 60 × 2,0



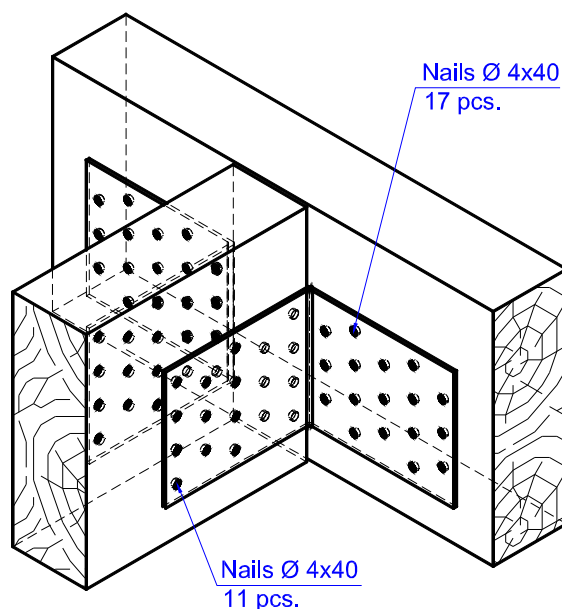
**Figure D.5.** Number and position of nails in the timber beam to timber beam connection with the angle brackets Angle bracket MK 100 × 100 × 60 × 2,0



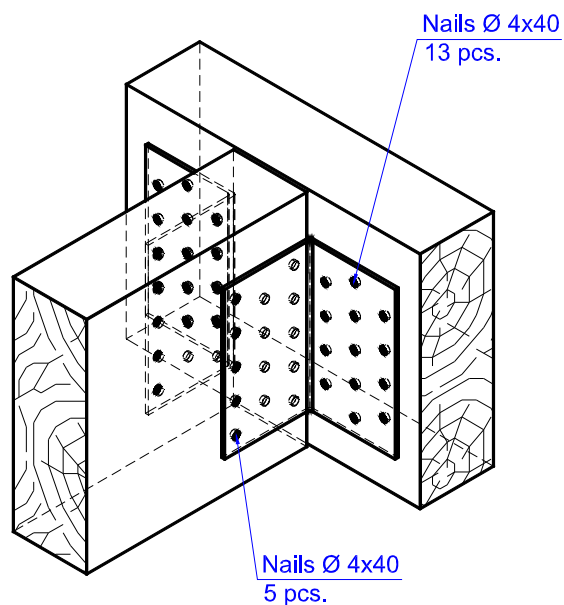
**Figure D.6.** Number and position of nails in the timber beam to timber beam connection with the angle brackets MK 60 × 60 × 80 × 2,0



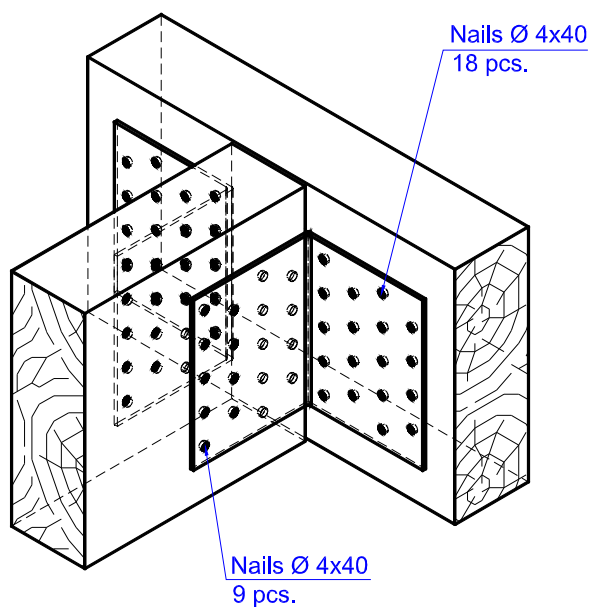
**Figure D.7.** Number and position of nails in the timber beam to timber beam connection with the angle brackets MK 80 × 80 × 80 × 2,0



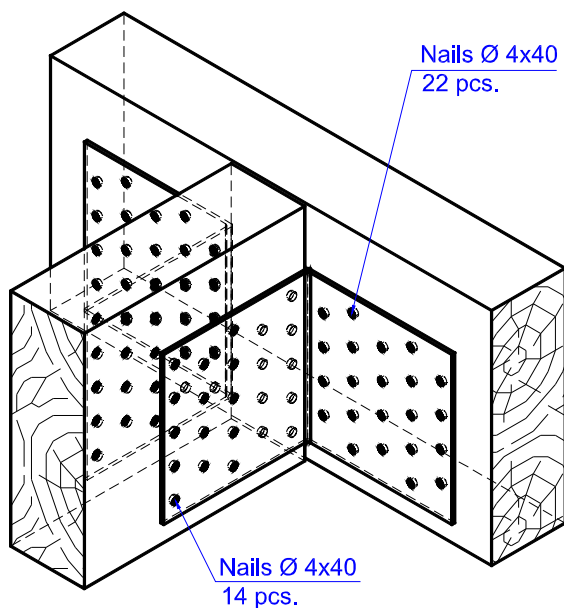
**Figure D.8.** Number and position of nails in the timber beam to timber beam connection with the angle brackets MK 100 × 100 × 80 × 2,0



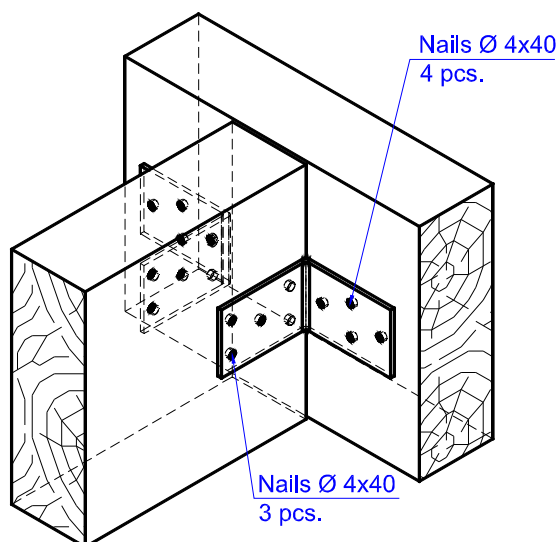
**Figure D.9.** Number and position of nails in the timber beam to timber beam connection with the angle brackets MK 60 × 60 × 100 × 2,0



**Figure D.10.** Number and position of nails in the timber beam to timber beam connection with the angle brackets MK 80 × 80 × 100 × 2,0

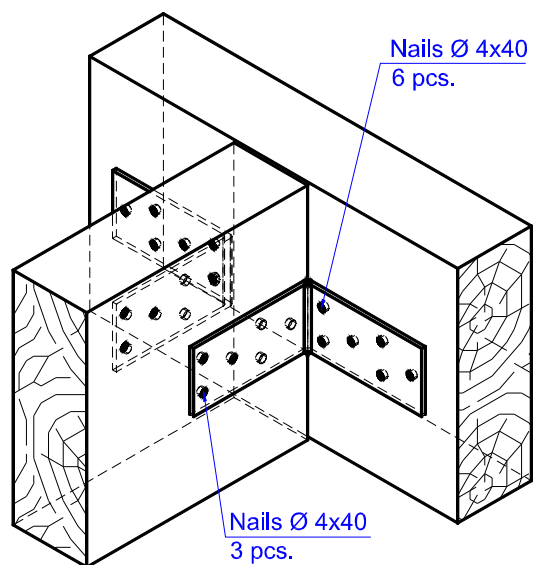


**Figure D.11.** Number and position of nails in the timber beam to timber beam connection with the angle brackets MK 100 × 100 × 100 × 2,0

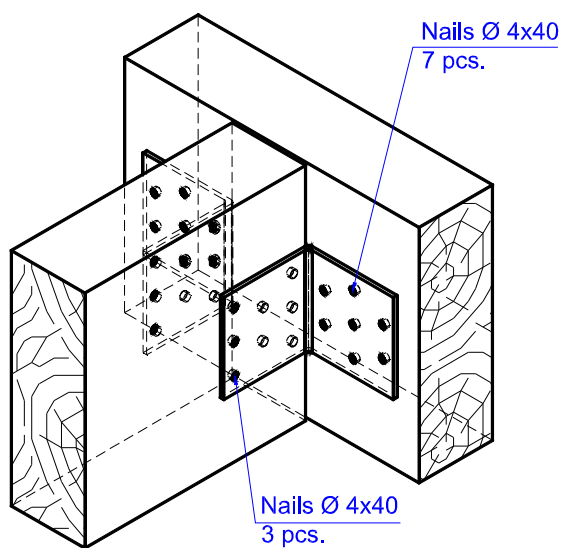


**Figure D.12.** Number and position of nails in the timber beam to timber beam connection with the angle brackets MK 60 × 60 × 40 × 2,5

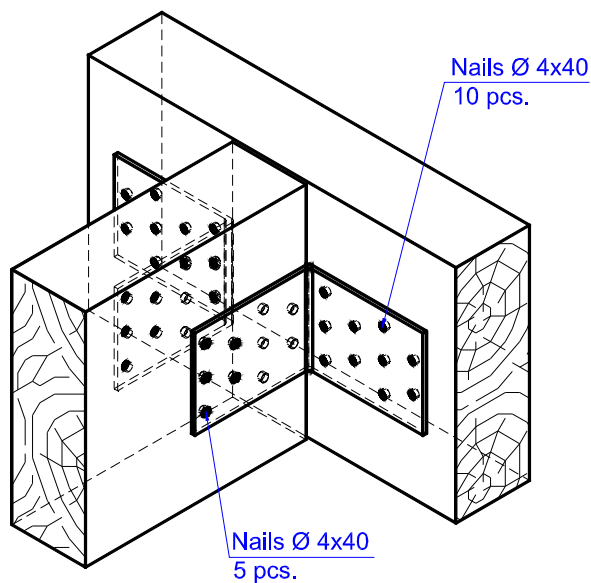




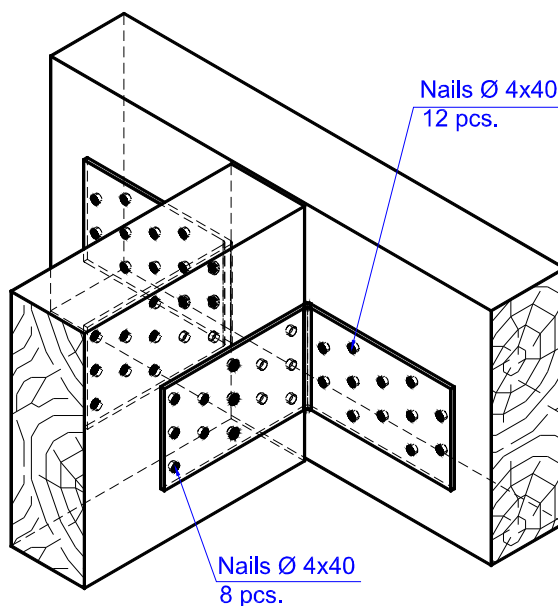
**Figure D.13.** Number and position of nails in the timber beam to timber beam connection with the angle brackets MK 80 × 80 × 40 × 2,5



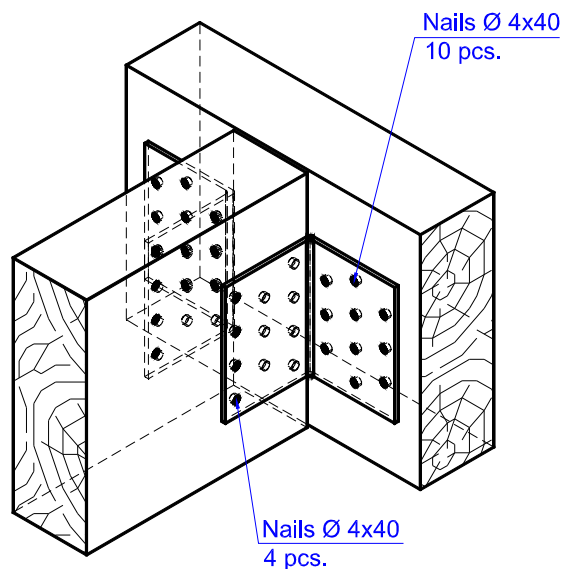
**Figure D.14.** Number and position of nails in the timber beam to timber beam connection with the angle brackets MK 60 × 60 × 60 × 2,5



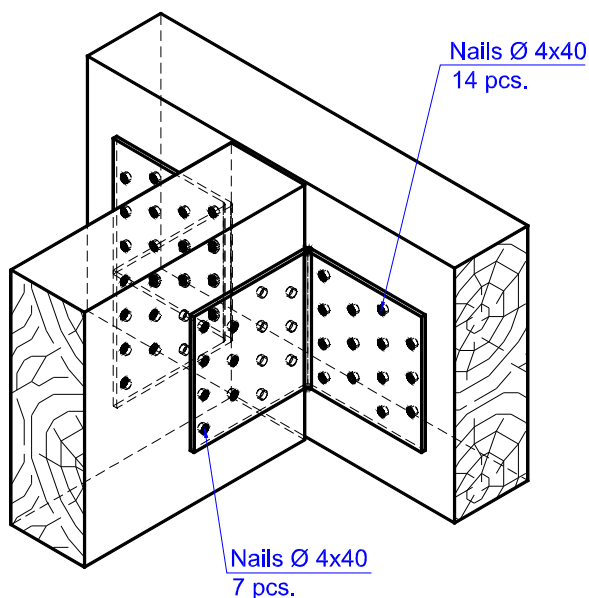
**Figure D.15.** Number and position of nails in the timber beam to timber beam connection with the angle brackets MK 80 × 80 × 60 × 2,5



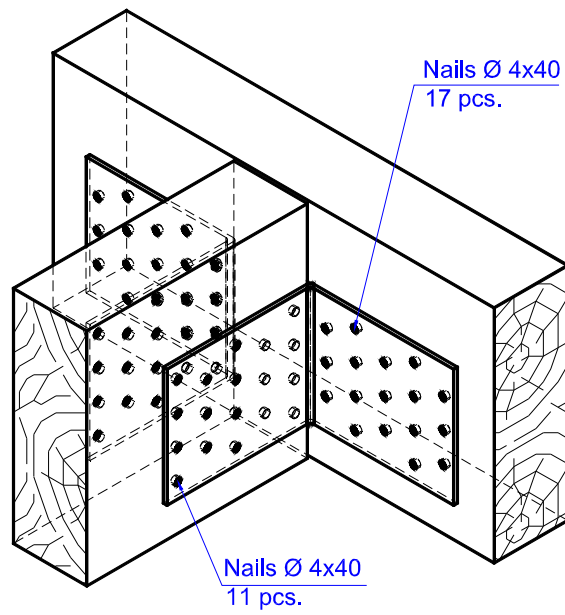
**Figure D.16.** Number and position of nails in the timber beam to timber beam connection with the angle brackets MK 100 × 100 × 60 × 2,5



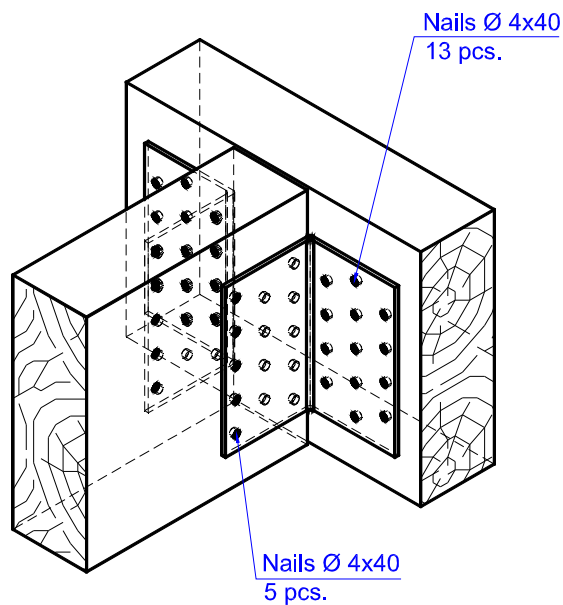
**Figure D.17.** Number and position of nails in the timber beam to timber beam connection with the angle brackets MK 60 × 60 × 80 × 2,5



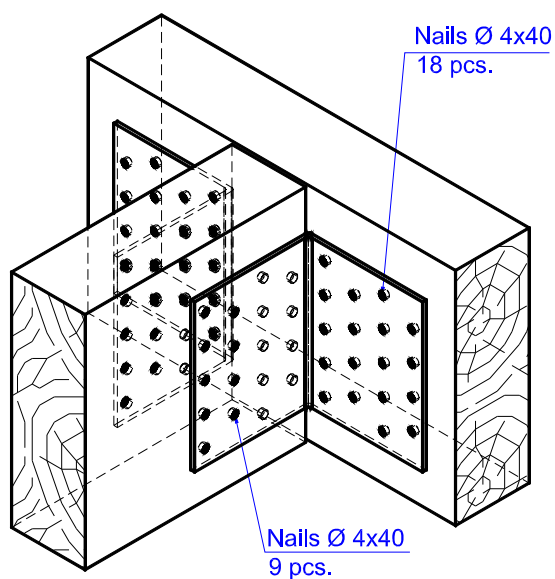
**Figure D.18.** Number and position of nails in the timber beam to timber beam connection with the angle brackets MK 80 × 80 × 80 × 2,5



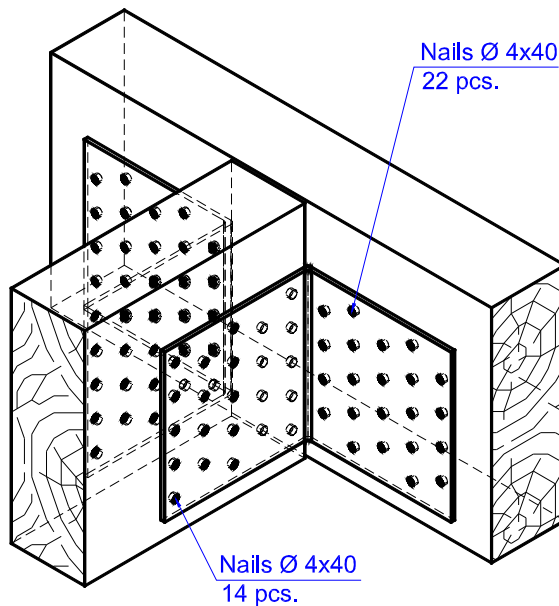
**Figure D.19.** Number and position of nails in the timber beam to timber beam connection with the angle brackets MK 100 × 100 × 80 × 2,5



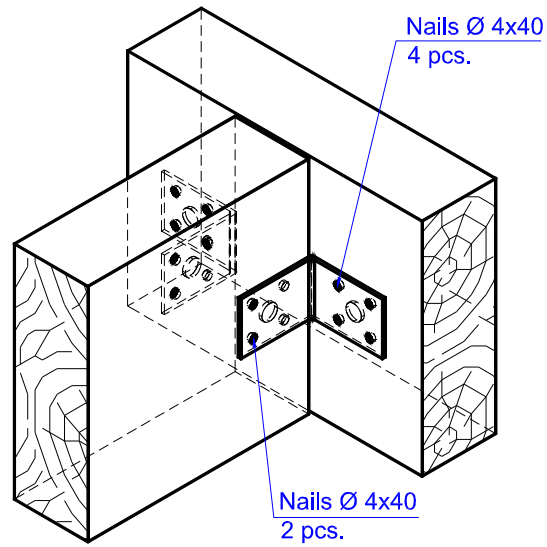
**Figure D.20.** Number and position of nails in the timber beam to timber beam connection with the angle brackets MK 60 × 60 × 100 × 2,5



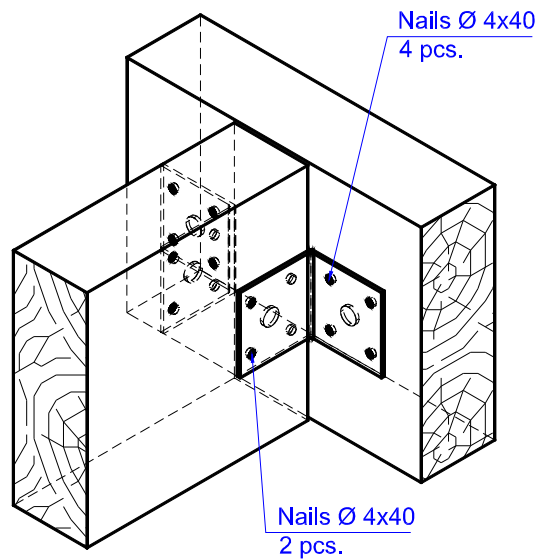
**Figure D.21.** Number and position of nails in the timber beam to timber beam connection with the angle brackets MK 80 × 80 × 100 × 2,5



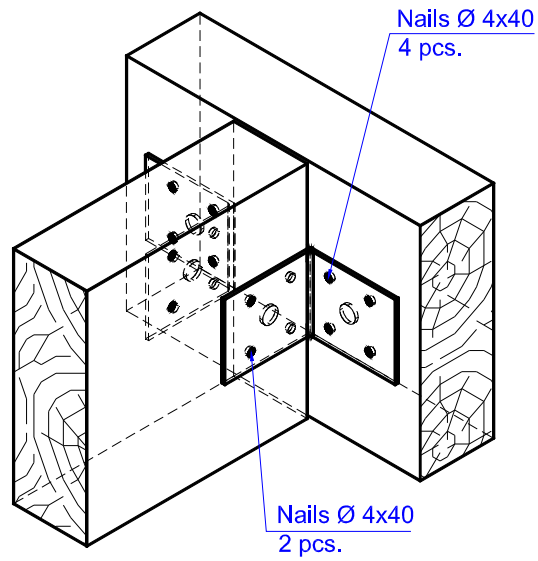
**Figure D.22.** Number and position of nails in the timber beam to timber beam connection with the angle brackets MK 100 × 100 × 100 × 2,5



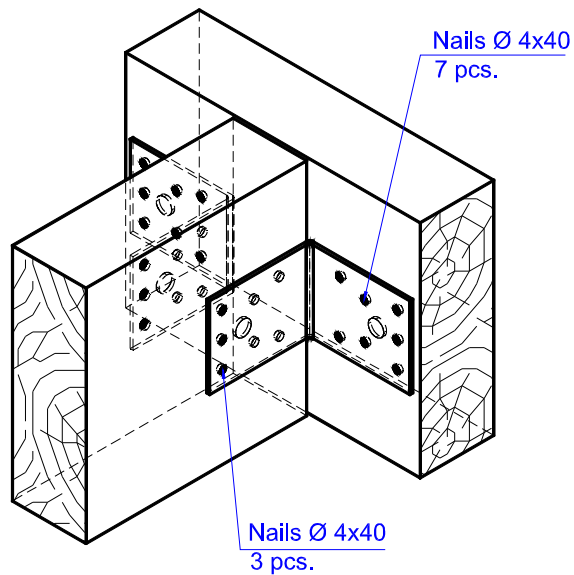
**Figure D.23.** Number and position of nails in the timber beam to timber beam connection with the angle brackets MK 50 × 50 × 35 × 2,0 and MK 50 × 50 × 35 × 2,5



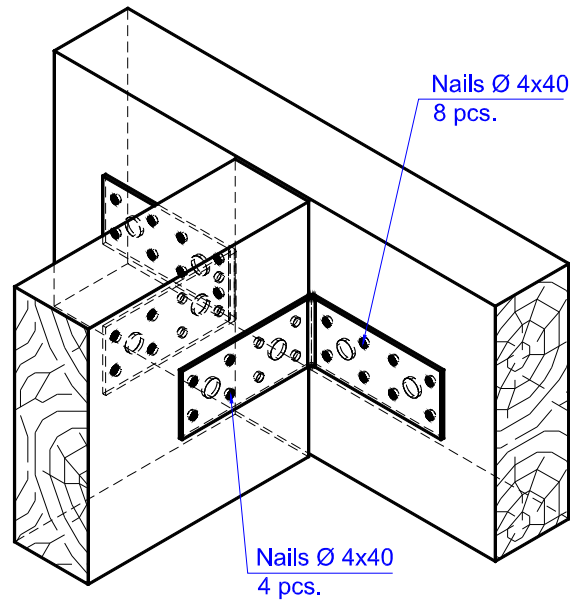
**Figure D.24.** Number and position of nails in the timber beam to timber beam connection with the angle brackets MK 50 × 50 × 50 × 2,0



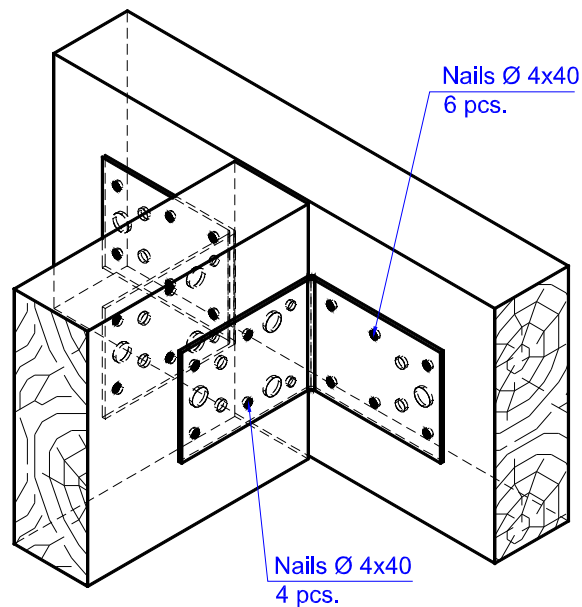
**Figure D.25.** Number and position of nails in the timber beam to timber beam connection with the angle brackets MK 60 × 60 × 50 × 2,0 and MK 60 × 60 × 50 × 2,5



**Figure D.26.** Number and position of nails in the timber beam to timber beam connection with the angle brackets MK 70 × 70 × 55 × 2,0 and MK 70 × 70 × 55 × 2,5

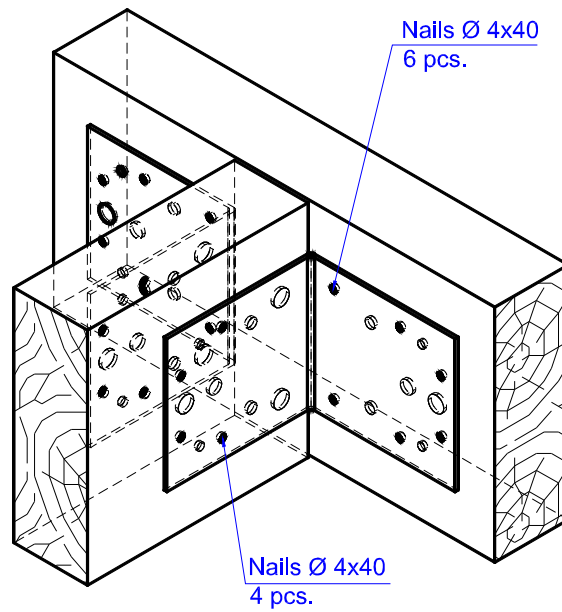


**Figure D.27.** Number and position of nails in the timber beam to timber beam connection with the angle brackets MK 90 × 90 × 40 × 2,0 , MK 90 × 90 × 65 × 2,5 and MK 90 × 90 × 65 × 3,0

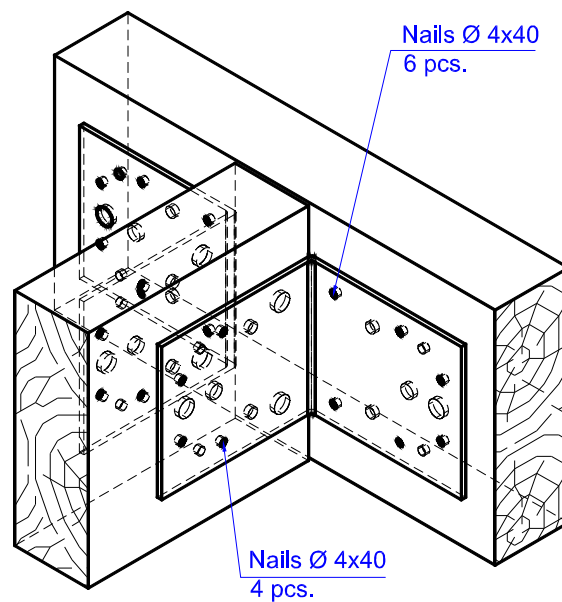


**Figure D.28.** Number and position of nails in the timber beam to timber beam connection with the angle brackets MK 90 × 90 × 65 × 2,0 and MK 90 × 90 × 65 × 2,5

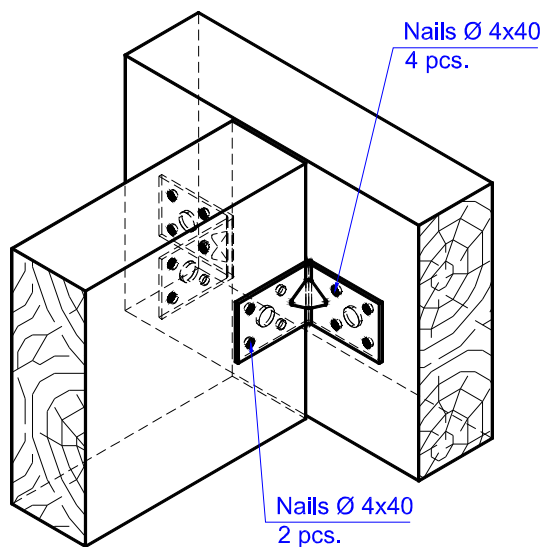




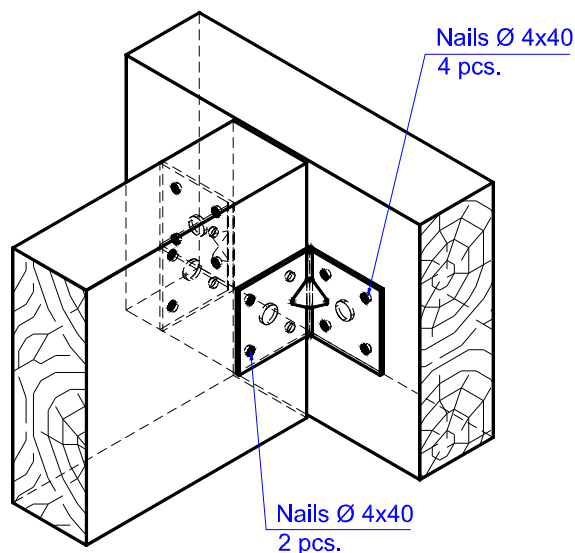
**Figure D.29.** Number and position of nails in the timber beam to timber beam connection with the angle brackets MK 100 × 100 × 90 × 2,0 and MK 100 × 100 × 90 × 2,5



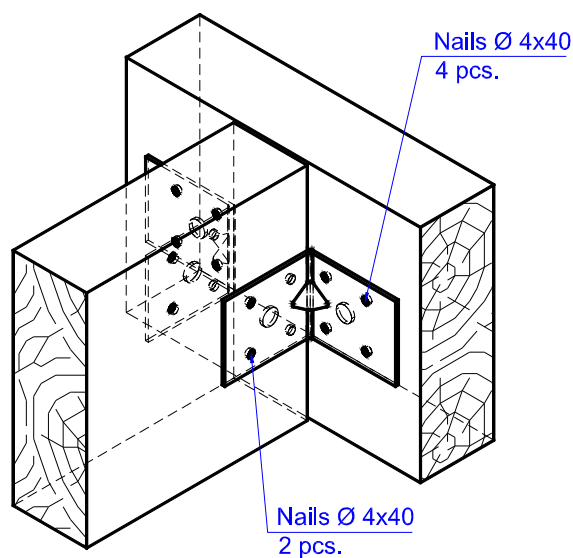
**Figure D.30.** Number and position of nails in the timber beam to timber beam connection with the angle brackets MK 105 × 105 × 90 × 3,0



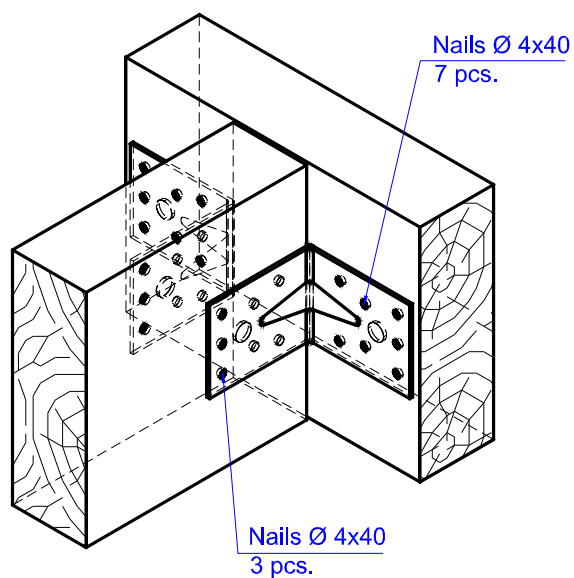
**Figure D.31.** Number and position of nails in the timber beam to timber beam connection with the angle brackets MKS 50 × 50 × 35 × 2,0 and MKS 50 × 50 × 35 × 2,5



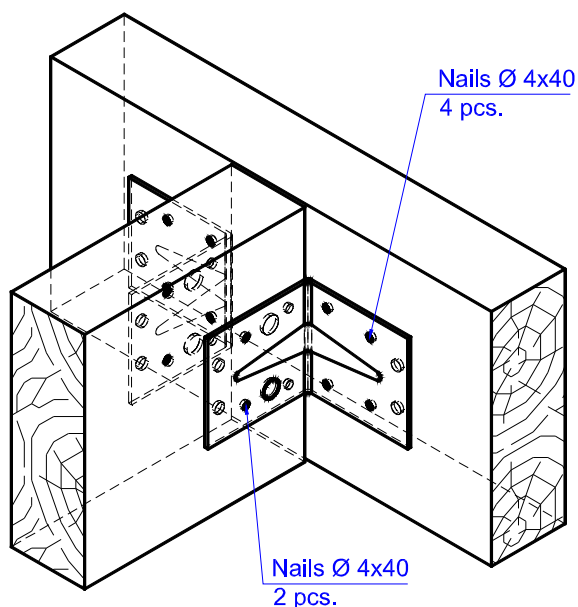
**Figure D.32.** Number and position of nails in the timber beam to timber beam connection with the angle brackets MKS 50 × 50 × 50 × 2,0 and MKS 50 × 50 × 50 × 2,5



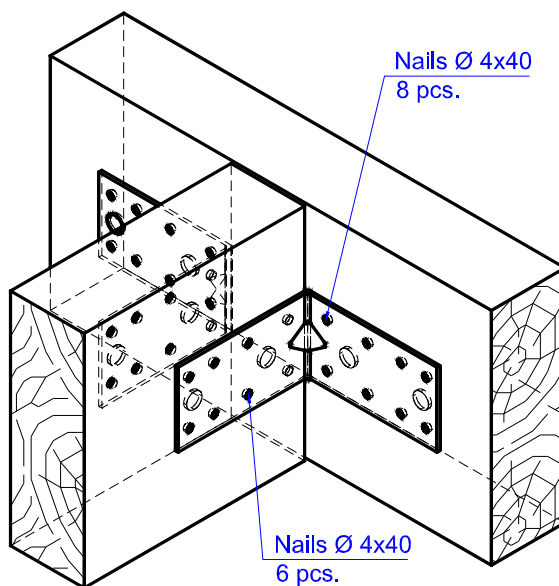
**Figure D.33.** Number and position of nails in the timber beam to timber beam connection with the angle brackets MKS 60 × 60 × 50 × 2,0 and MKS 60 × 60 × 50 × 2,5



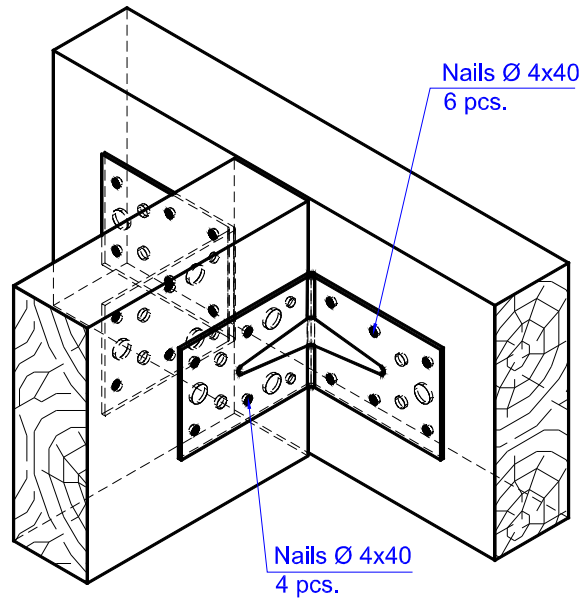
**Figure D.34.** Number and position of nails in the timber beam to timber beam connection with the angle brackets MKS 70 × 70 × 55 × 2,0 and MKS 70 × 70 × 55 × 2,5



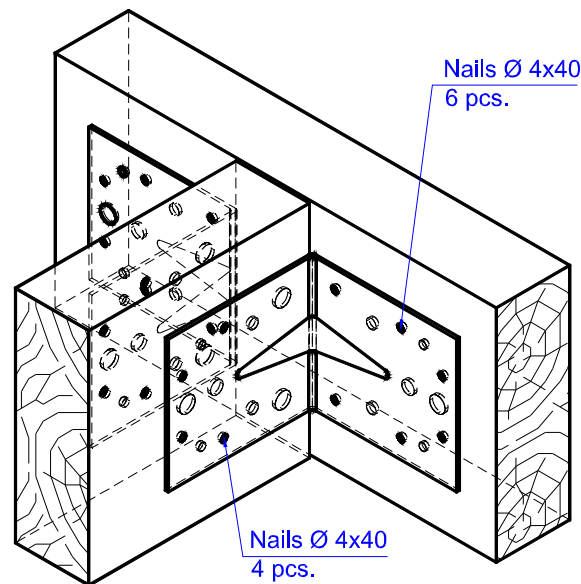
**Figure D.35.** Number and position of nails in the timber beam to timber beam connection with the angle brackets MKS 70 × 70 × 65 × 2,0



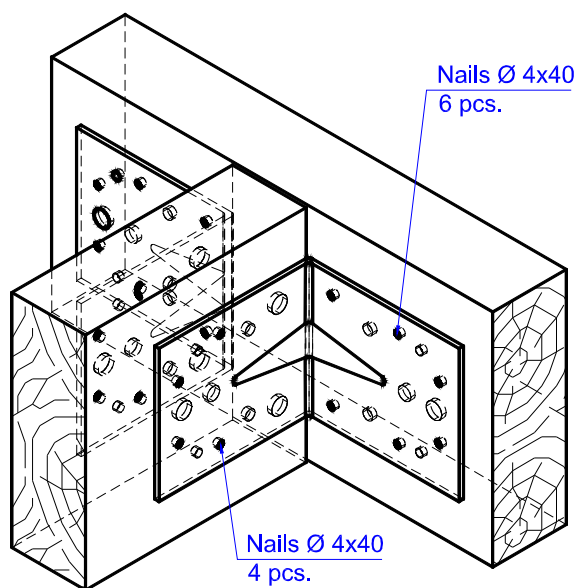
**Figure D.36.** Number and position of nails in the timber beam to timber beam connection with the angle brackets MKS 90 × 90 × 50 × 2,0 and MKS 90 × 90 × 50 × 2,5



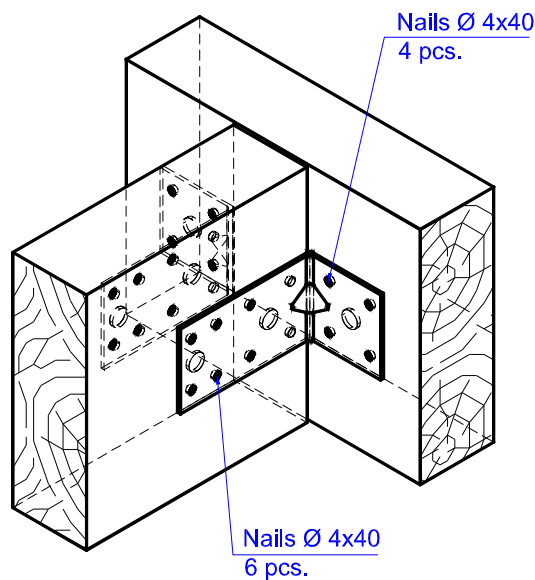
**Figure D.37.** Number and position of nails in the timber beam to timber beam connection with the angle brackets MKS 90 × 90 × 65 × 2,0 and MKS 90 × 90 × 65 × 2,5



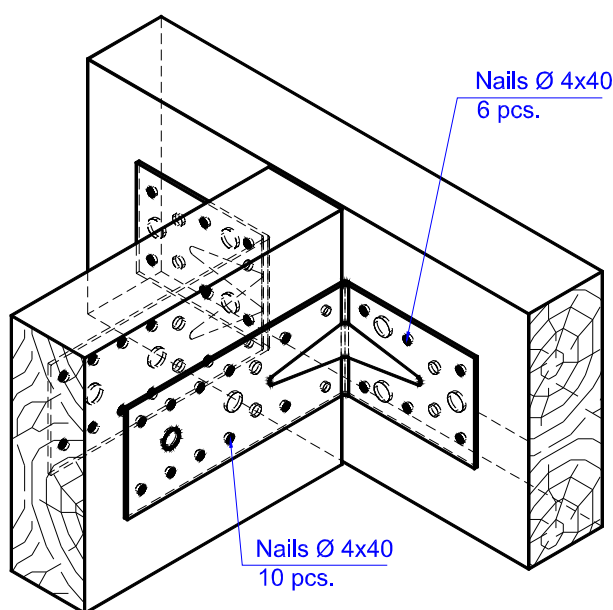
**Figure D.38.** Number and position of nails in the timber beam to timber beam connection with the angle brackets MKS 100 × 100 × 90 × 2,0 and MKS 100 × 100 × 90 × 2,5



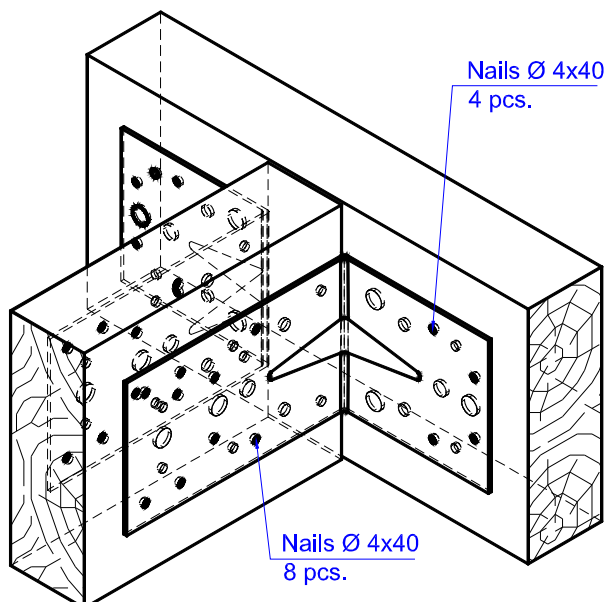
**Figure D.39.** Number and position of nails in the timber beam to timber beam connection with the angle brackets MKS 105 x 105 x 90 x 3,0



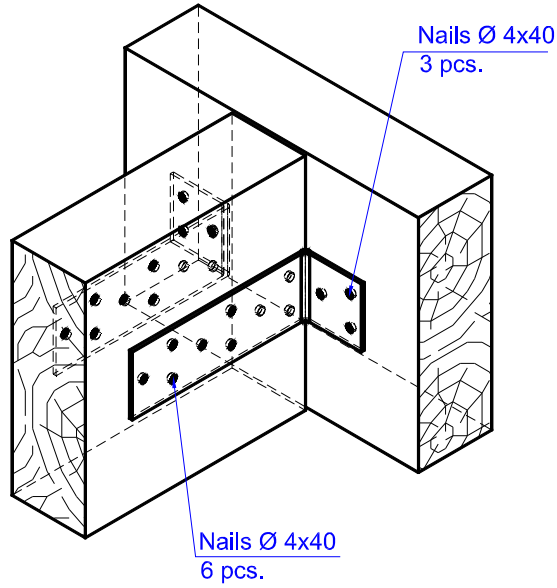
**Figure D.40.** Number and position of nails in the timber beam to timber beam connection with the angle brackets MKNS 90 x 50 x 50 x 2,0 and MKNS 90 x 50 x 50 x 2,5



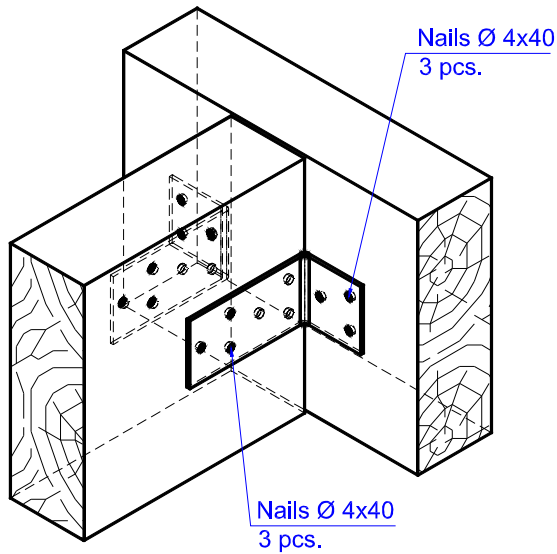
**Figure D.41.** Number and position of nails in the timber beam to timber beam connection with the angle brackets MKNS 150 x 90 x 65 x 2,0 and MKNS 150 x 90 x 65 x 2,5



**Figure D.42.** Number and position of nails in the timber beam to timber beam connection with the angle brackets MKNS 150 x 100 x 90 x 2,0 and MKNS 150 x 100 x 90 x 2,5

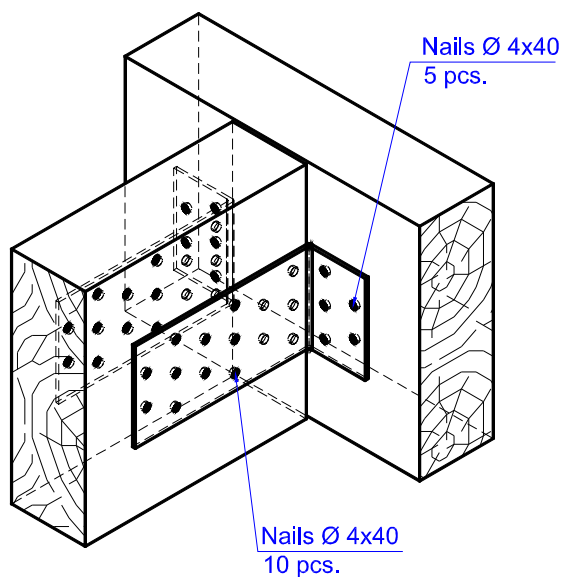


**Figure D.43.** Number and position of nails in the timber beam to timber beam connection with the angle brackets MKN 120 × 40 × 40 × 2,0

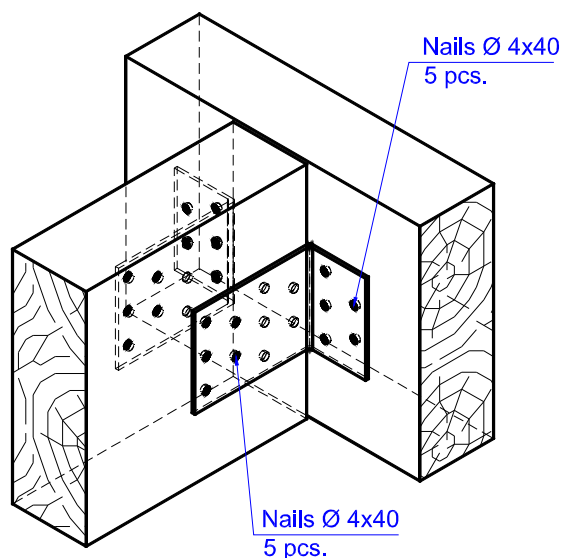


**Figure D.44.** Number and position of nails in the timber beam to timber beam connection with the angle brackets MKN 80 × 40 × 40 × 2,0

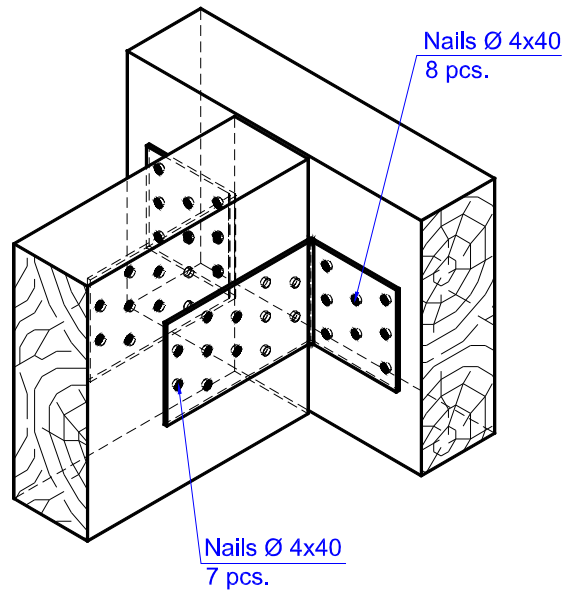




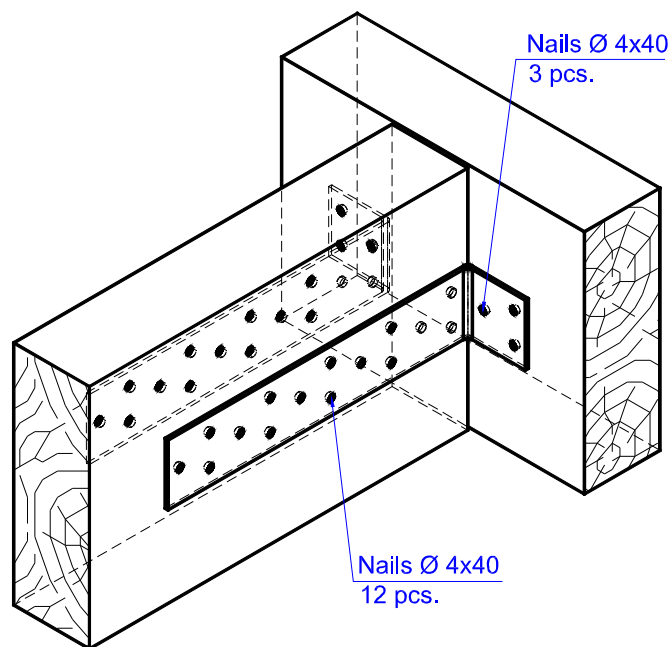
**Figure D.45.** Number and position of nails in the timber beam to timber beam connection with the angle brackets MKN 120 × 40 × 60 × 2,0



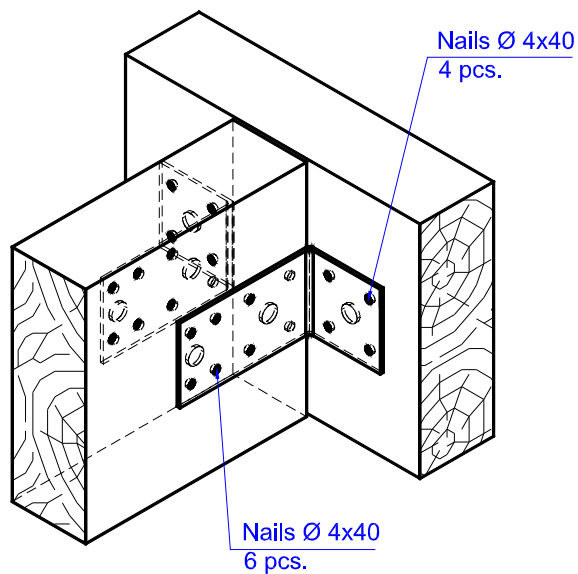
**Figure D.46.** Number and position of nails in the timber beam to timber beam connection with the angle brackets MKN 80 × 40 × 60 × 2,0



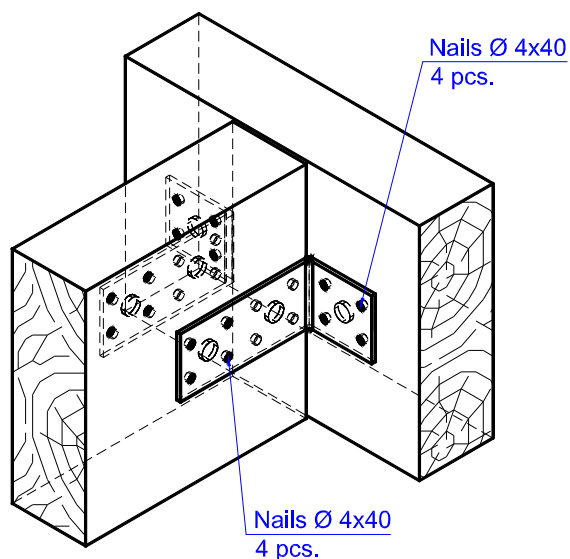
**Figure D.47.** Number and position of nails in the timber beam to timber beam connection with the angle brackets MKN 100 × 60 × 60 × 2,0



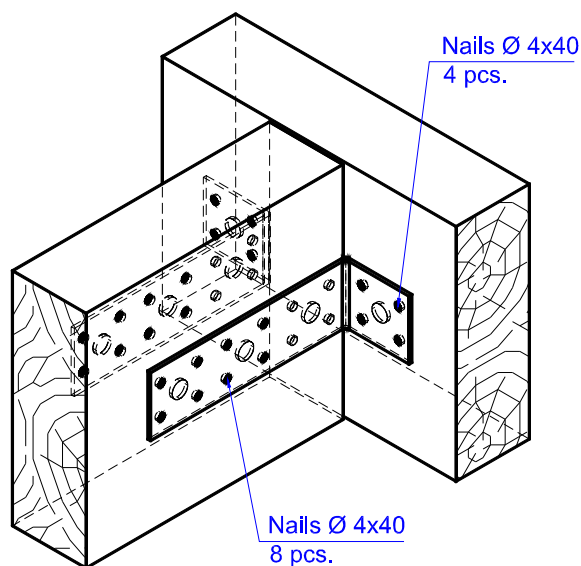
**Figure D.48.** Number and position of nails in the timber beam to timber beam connection with the angle brackets MKN 200 × 40 × 40 × 2,0



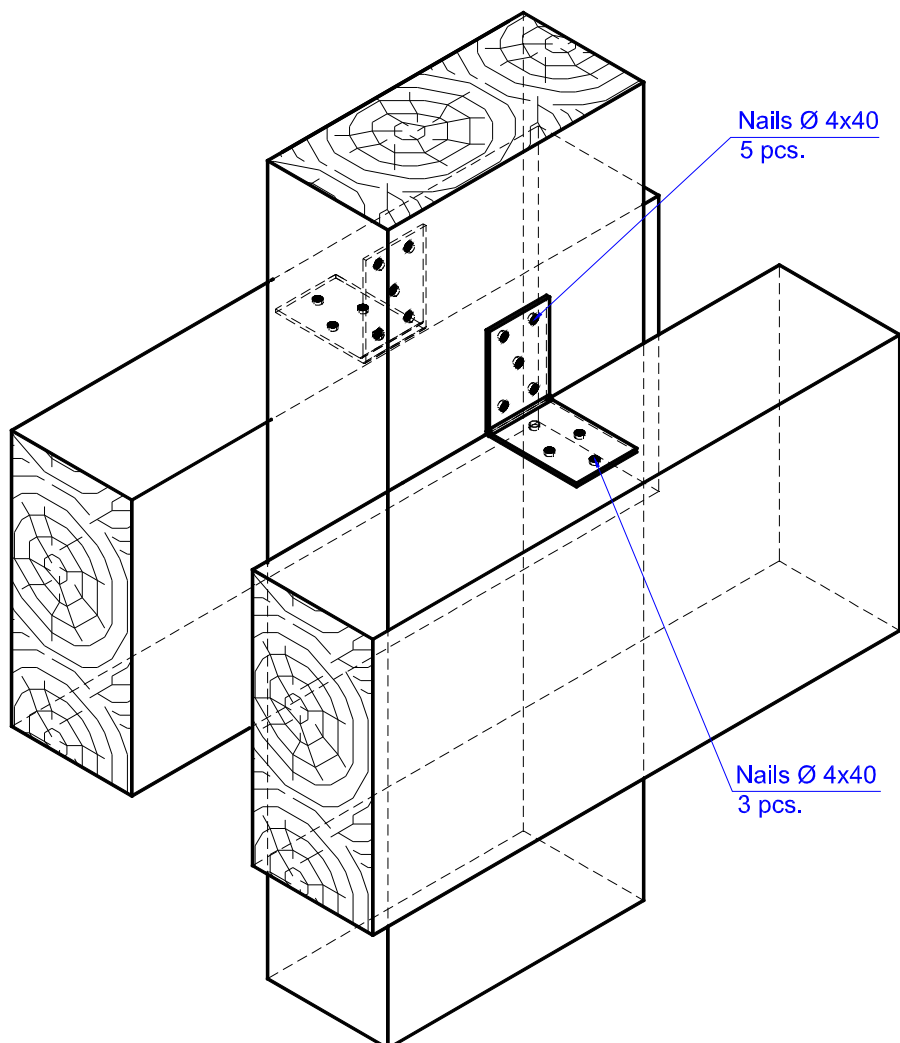
**Figure D.49.** Number and position of nails in the timber beam to timber beam connection with the angle brackets MKN 90 × 50 × 50 × 2,0 and MKN 90 × 50 × 50 × 2,5



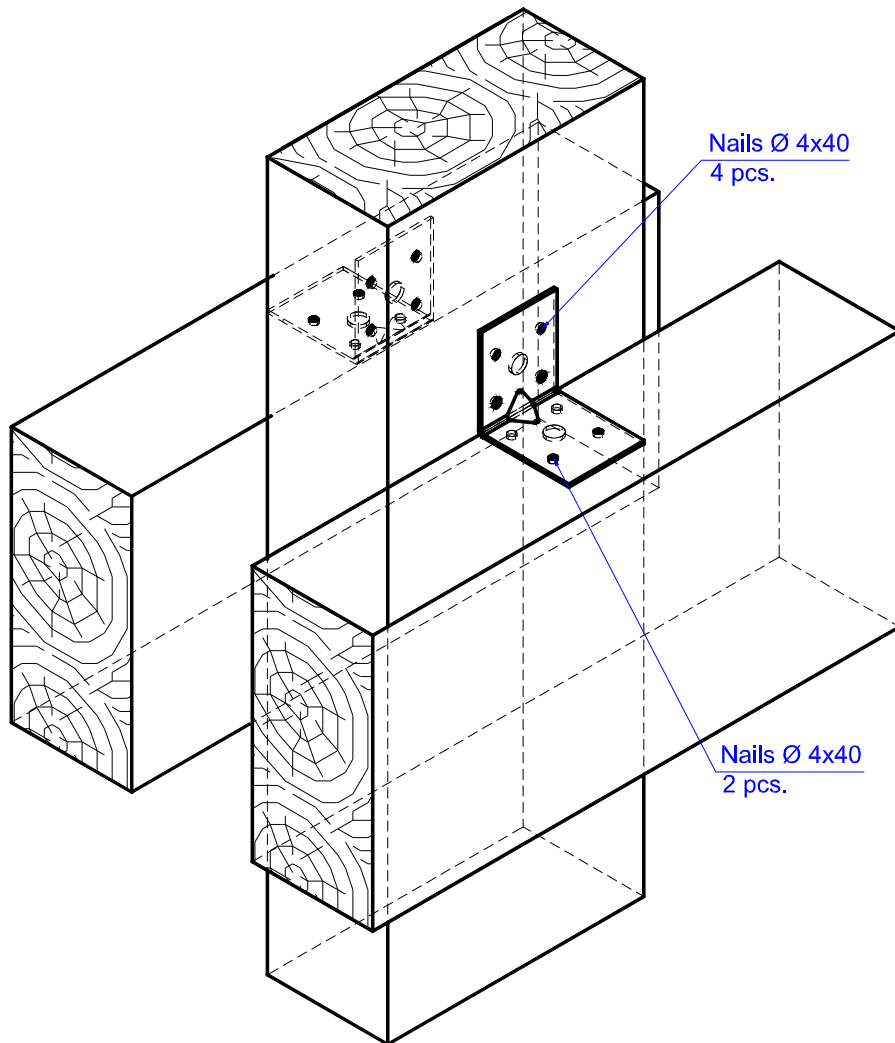
**Figure D.50.** Number and position of nails in the timber beam to timber beam connection with the angle brackets MKN 95 × 45 × 40 × 2,5



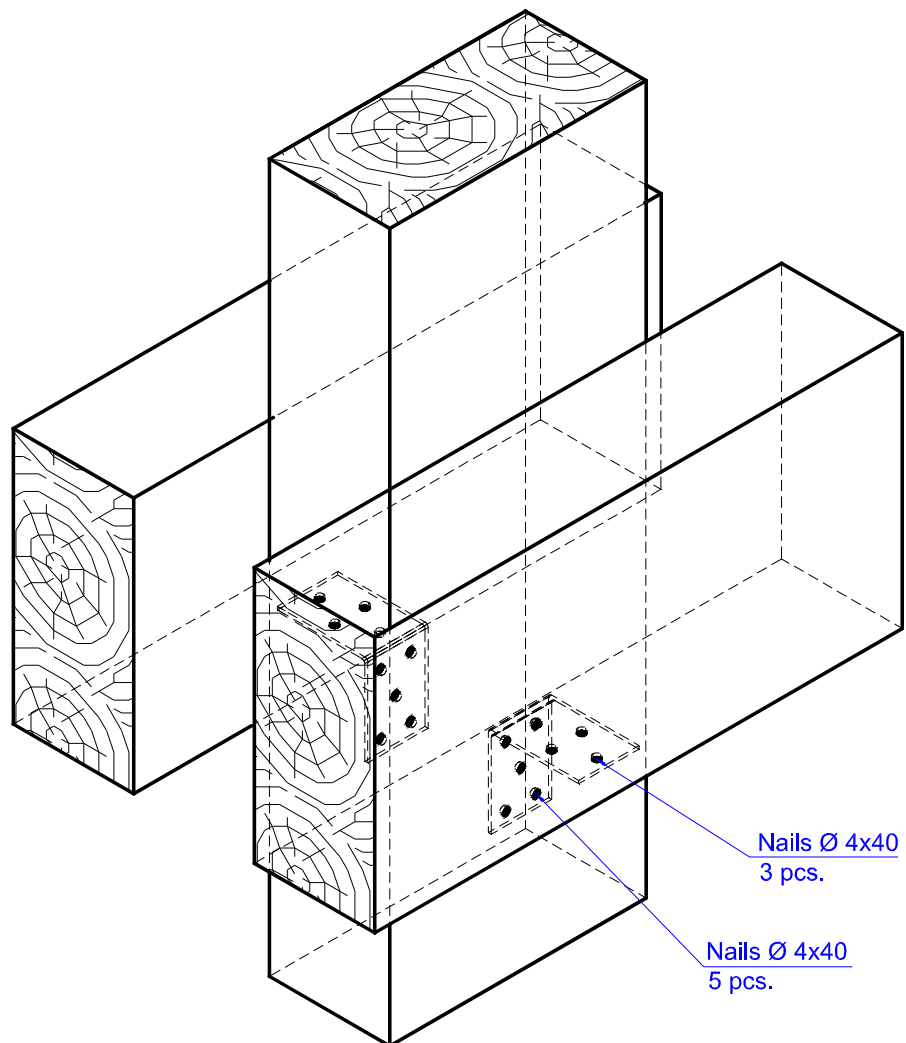
**Figure D.51.** Number and position of nails in the timber beam to timber beam connection with the angle brackets MKN 135 x 45 x 40 x 2,0 and MKN 135 x 45 x 40 x 2,5



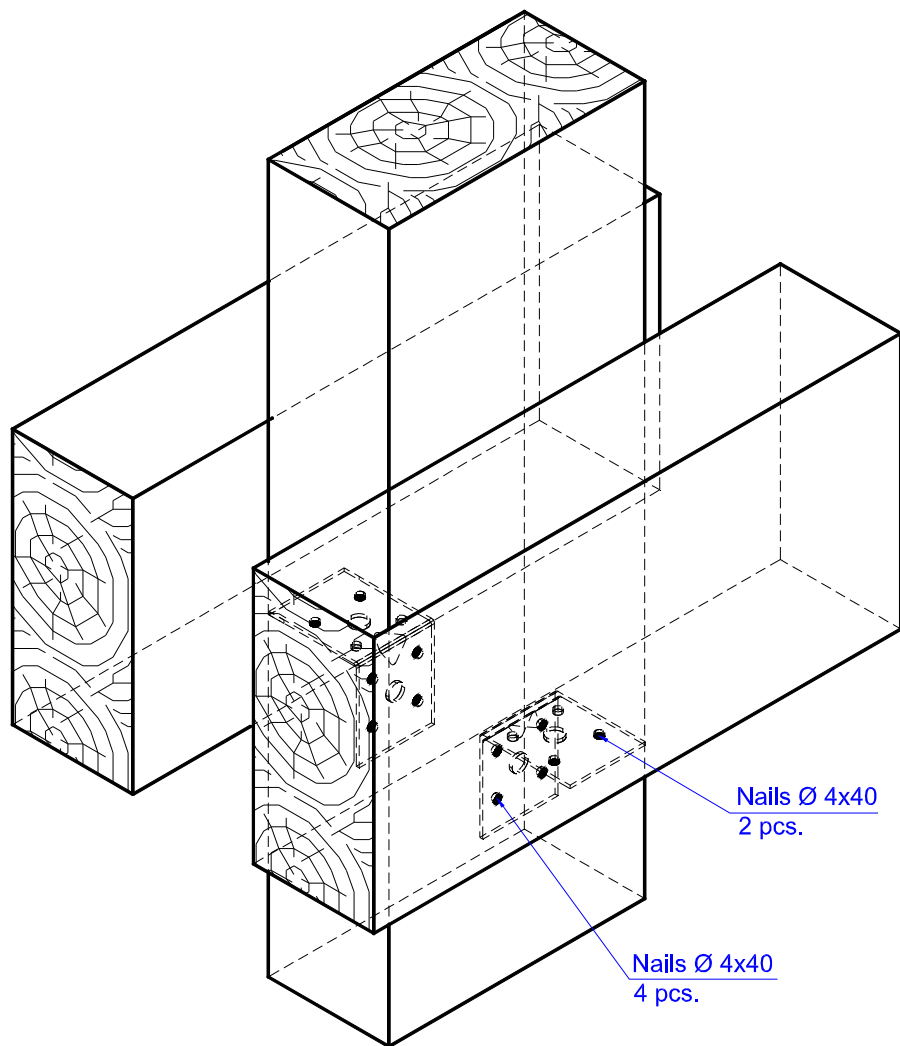
**Figure D.52.** Number and position of nails in the timber beam to timber column connection with the angle brackets MK 60 x 60 x 40 x 2,0



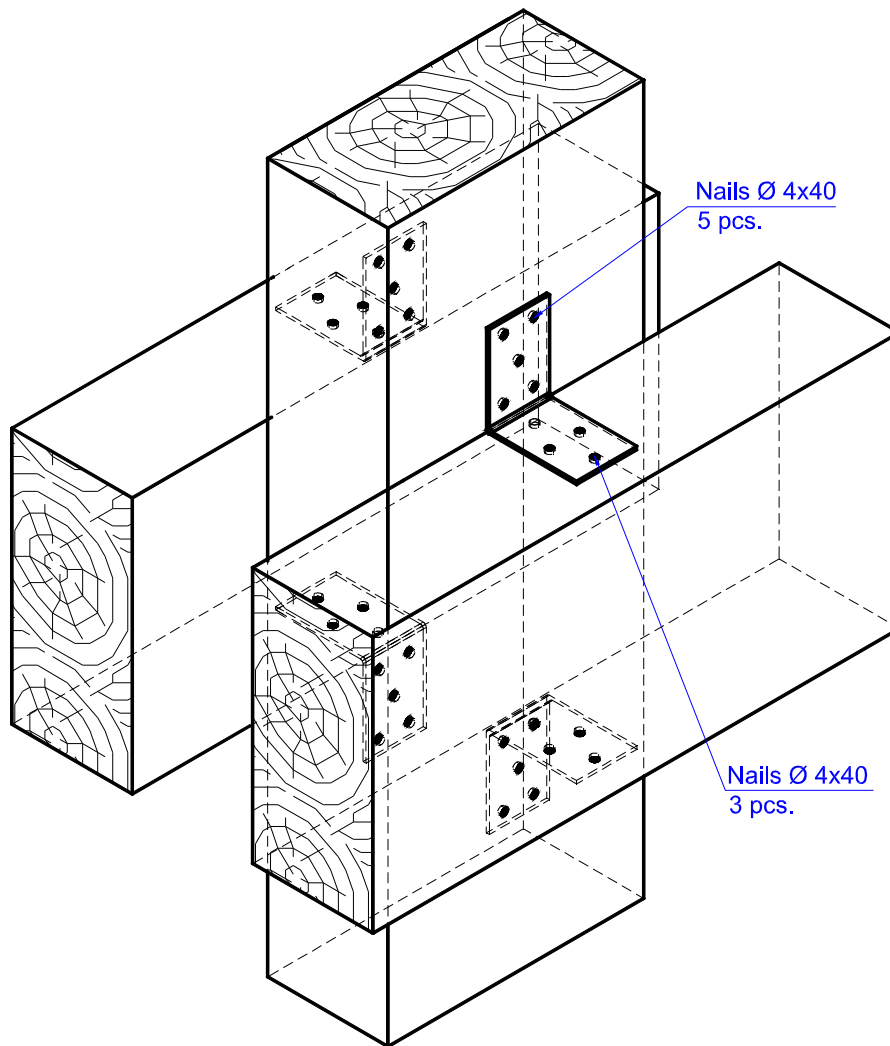
**Figure D.53.** Number and position of nails in the timber beam to timber column connection with the angle brackets MKS 60 x 60 x 50 x 2,0



**Figure D.54.** Number and position of nails in the timber beam to timber column connection with the angle brackets MK 60 x 60 x 40 x 2,0

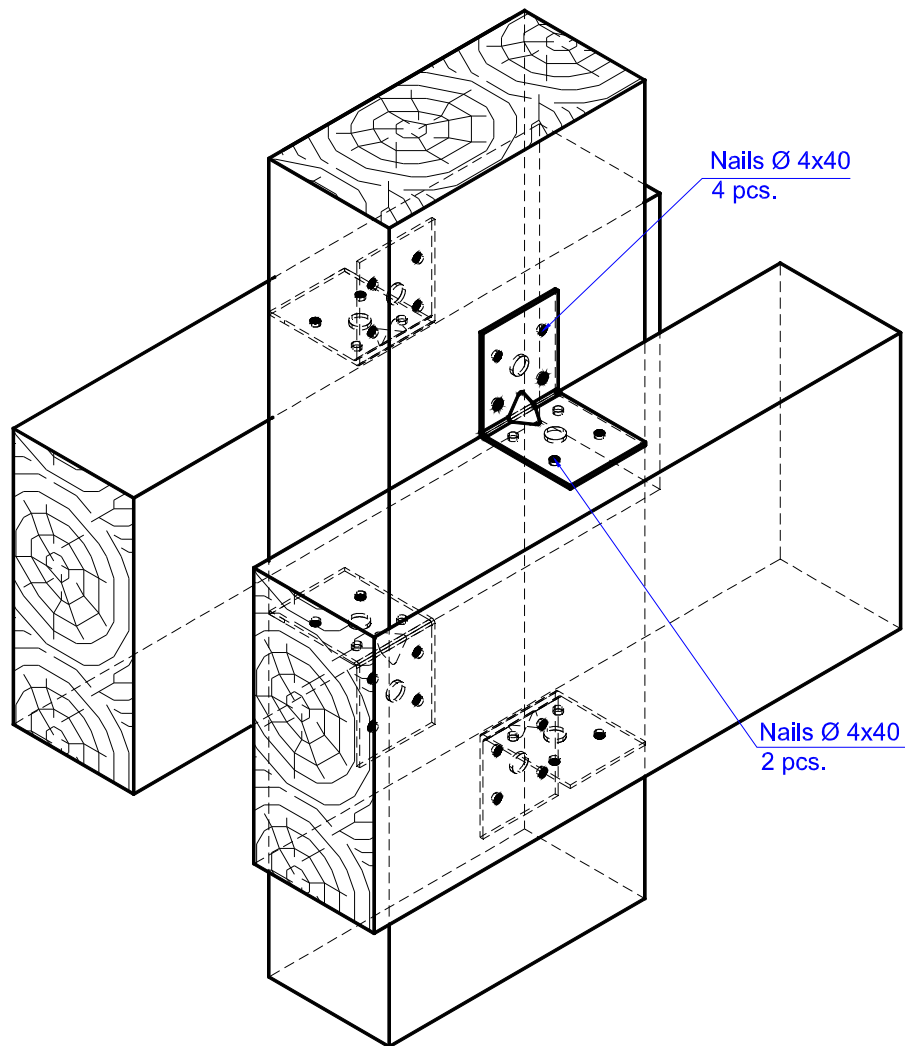


**Figure D.55.** Number and position of nails in the timber beam to timber column connection with the angle brackets MKS 60 x 60 x 50 x 2,0



**Figure D.56.** Number and position of nails in the timber beam to timber column connection with the angle brackets MK 60 × 60 × 40 × 2,0





**Figure D.57.** Number and position of nails in the timber beam to timber column connection with the angle brackets MKS 60 x 60 x 50 x 2,0