

ETA-Danmark A/S  
Kollegievej 6  
DK-2920 Charlottenlund  
Tel. +45 72 24 59 00  
Fax +45 72 24 59 04  
Internet [www.etadanmark.dk](http://www.etadanmark.dk)



Authorised and notified according to Article 10 of the Council Directive 89/106/EEC of 21 December 1988 on the approximation of laws, regulations and administrative provisions of Member States relating to construction products

MEMBER OF EOTA

## European Technical Approval ETA-08/0063

*This ETA replaces the previous ETA with the same number and validity from 2010-11-19 to 2013-03-17*

Trade name:	FraP Joist Hangers
Holder of approval:	FraP Metall GmbH Triftstrasse 21B D-16348 Wandlitz Tel. +49 33 397 64 313 Fax +49 33 397 64 314 Internet <a href="http://www.frap-metall.de">www.frap-metall.de</a>
Generic type and use of construction product:	Three-dimensional nailing plate (Joist hanger for wood to wood connections and wood to concrete or steel connections)
Valid from: to:	2013-03-17 2018-03-17
Manufacturing plant:	UAB Toga Elektrenai Obeniu k. Kietaviskiu sen. LT-21413 Elektrėnu sav.
This European Technical Approval contains:	84 pages including 3 annexes which form an integral part of the document



European Organisation for Technical Approvals

Europæisk Organisation for Tekniske Godkendelser

## **I LEGAL BASIS AND GENERAL CONDITIONS**

1 This European Technical Approval is issued by ETA-Danmark A/S in accordance with:

- Council Directive 89/106/EEC of 21 December 1988 on the approximation of laws, regulations and administrative provisions of Member States relating to construction products<sup>1)</sup>, as amended by Council Directive 93/68/EEC of 22 July 1993<sup>2)</sup>.
- Bekendtgørelse 559 af 27-06-1994 (afløser bekendtgørelse 480 af 25-06-1991) om ikrafttræden af EF direktiv af 21. december 1988 om indbyrdes tilnærmelse af medlemsstaternes love og administrative bestemmelser om byggevarer.
- Common Procedural Rules for Requesting, Preparing and the Granting of European Technical Approvals set out in the Annex to Commission Decision 94/23/EC<sup>3)</sup>.
- EOTA Guideline ETAG 015 *Three-dimensional nailing plates*, September 2002 edition.

2 ETA-Danmark A/S is authorized to check whether the provisions of this European Technical Approval are met. Checking may take place in the manufacturing plant. Nevertheless, the responsibility for the conformity of the products to the European Technical Approval and for their fitness for the intended use remains with the holder of the European Technical Approval.

3 This European Technical Approval is not to be transferred to manufacturers or agents of manufacturers other than those indicated on page 1, or manufacturing plants other than those indicated on page 1 of this European Technical Approval.

4 This European Technical Approval may be withdrawn by ETA-Danmark A/S pursuant to Article 5(1) of Council Directive 89/106/EEC.

- 1) Official Journal of the European Communities N° L40, 11 Feb 1989, p 12.
- 2) Official Journal of the European Communities N° L220, 30 Aug 1993, p 1.
- 3) Official Journal of the European Communities N° L 17, 20 Jan 1994, p 34.

5 Reproduction of this European Technical Approval including transmission by electronic means shall be in full. However, partial reproduction can be made with the written consent of ETA-Danmark A/S. In this case partial reproduction has to be designated as such. Texts and drawings of advertising brochures shall not contradict or misuse the European Technical Approval.

6 This European Technical Approval is issued by ETA-Danmark A/S in English. This version corresponds fully to the version circulated within EOTA. Translations into other languages have to be designated as such.

## I SPECIAL CONDITIONS OF THE EUROPEAN TECHNICAL APPROVAL

### 1 Definition of product and intended use

#### Definition of the product

FraP joist hangers are one-piece non-welded, face-fixed joist hangers to be used in timber to timber connections as well as connections between a timber joist and a concrete structure or a steel member.

The joist hangers are made from pre-galvanized steel Grade DX51D + Z (min Z275) according to EN 10346:2009 with minimum  $R_{eH}$  of 250 MPa, minimum tensile strength  $R_m$  of 330 MPa and minimum ultimate strain  $A_{80}$  of 19 % with tolerances according to EN 10143:1993 or steel grade S320GD Z275 according to EN 10346:2009 with a minimum yield strength  $R_e$  of 320 MPa, a minimum tensile strength  $R_m$  of 390 MPa and a minimum ultimate strain  $A_{80}$  of 17 % or from stainless steel (1.4301, 1.4401, 1.4541, 1.4571 or 1.4016 according to EN 10088) with equivalent characteristics. Dimensions, hole positions, steel type and typical installations are shown in Annex A.

#### Intended use

The joist hangers are intended for use in making end-grain to side-grain connections in load bearing timber structures, as a connection between a wood based joist and a solid timber or wood based header, where requirements for mechanical resistance and stability and safety in use in the sense of the Essential Requirements 1 and 4 of Council Directive 89/106/EEC shall be fulfilled. They are also intended for use in making an end-grain connection between a timber joist and a concrete structure or a steel member.

The joist hangers can be installed as connections between wood based members such as:

- Structural solid timber classified to C14-C40 according to EN 338 / EN 14081,
- Glulam classified to GL24-GL36 according to EN 1194 / EN 14080,
- LVL according to EN 14374,
- Parallam PSL,
- Intrallam LSL,
- Duo- and Triobalken,
- Layered wood plates,
- I-beams with backer blocks on both sides of the web in the header and web stiffeners in the joist
- Plywood according to EN 636

However, the calculation methods are only allowed for a characteristic wood density of up to  $460 \text{ kg/m}^3$ . Even though the wood based material may have a larger density, this must not be used when calculating the load-carrying capacities of the fasteners.

Annex B states the formulas for the characteristic load-

carrying capacities of the joist hanger connections.

The design of the connections shall be in accordance with Eurocode 5 or a similar national Timber Code.

It is assumed that the forces acting on the joist hanger connection are  $F_{up}$ ,  $F_{down}$  and  $F_{lat}$ , as shown in the figure below. The forces  $F_{up}$  and  $F_{down}$  shall act in the middle of the joist hanger. The force  $F_{lat}$  is assumed to act  $e_{J,90}$  above the centre of gravity of the nails in the joist. It is assumed that the forces are acting right at the end of the joist.

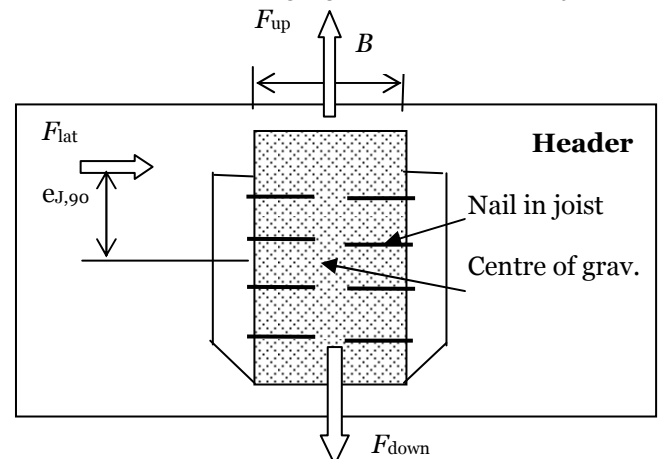

It is assumed that the header is prevented from rotating. Similar it is assumed that the concrete structure or the steel member, to which the joist hanger is bolted, does not rotate. If the header beam only has installed a joist hanger on one side, the eccentricity moment  $M_v = F_d \cdot (B_H / 2 + 30\text{mm})$  shall be considered. The same applies when the header has joist hanger connections on both sides, but with vertical forces which differ more than 20%.

It is a condition for a force  $F_{lat}$  perpendicular to the vertical symmetry line that the joist hanger is connected to a wood-based header with nails in all holes (full nailing) or in all holes marked for partial nailing.

The joist hangers are intended for use for connections subject to static or quasi static loading.

The zinc-coated hangers are for use in timber structures subject to dry, internal conditions defined by the service classes 1 and 2 of EN 1995-1-1:2004, (Eurocode 5). Hangers made from stainless steel are for use in service classes 1, 2 and 3 of EN 1995-1-1:2004, (Eurocode 5).

**Assumed working life**

The assumed intended working life of the joist hangers for the intended use is 50 years, provided that they are subject to appropriate use and maintenance.

The information on the working life should not be regarded as a guarantee provided by the manufacturer or ETA Danmark. An “assumed intended working life” means that it is expected that, when this working life has elapsed, the real working life may be, in normal use conditions, considerably longer without major degradation affecting the essential requirements.

## 2 Characteristics of product and assessment

ETAG paragraph	Characteristic	Assessment of characteristic
<b>2.1 Mechanical resistance and stability*)</b>		
6.1.1	Characteristic load-carrying capacity	See Annex B
6.1.2	Stiffness	No performance determined
6.1.3	Ductility in cyclic testing	No performance determined
<b>2.2 Safety in case of fire</b>		
6.2.1	Reaction to fire	The joist hangers are made from steel classified as <b>Euroclass A1</b> in accordance with EN 1350-1 and EC decision 96/603/EC, amended by EC Decision 2000/605/EC
<b>2.3 Hygiene, health and the environment</b>		
6.3.1	Influence on air quality	No dangerous materials **)
<b>2.4 Safety in use</b>		
<b>2.5 Protection against noise</b>		
<b>2.6 Energy economy and heat retention</b>		
<b>2.7 Related aspects of serviceability</b>		
6.7.1	Durability	The joist hangers have been assessed as having satisfactory durability and serviceability when used in timber structures using the timber species described in Eurocode 5 and subject to the conditions defined by service class 1 and 2
6.7.2	Serviceability	
6.7.3	Identification	

\*) See page 5 of this ETA

\*\*) In accordance with <http://europa.eu.int/comm/enterprise/construction/internal/dangsub/dangmain.htm> In addition to the specific clauses relating to dangerous substances contained in this European Technical Approval, there may be other requirements applicable to the products falling within its scope (e.g. transposed European legislation and national laws, regulations and administrative provisions). In order to meet the provisions of the EU Construction Products Directive, these requirements need also to be complied with, when and where they apply.

## Safety principles and partial factors

### 2.1 Mechanical resistance and stability

See annex B for characteristic load-carrying capacities of the joist hangers.

The characteristic capacities of the joist hangers are determined by calculation assisted by testing as described in the EOTA Guideline 015 clause 5.1.2. They should be used for designs in accordance with Eurocode 5 or a similar national Timber Code.

The design models allow the use of fasteners described in the table on page 21 in Annex A:

*Threaded nails (ringed shank nails) in accordance to EN 14592*

In the formulas in Annex B the capacities for threaded nails calculated according to Eurocode 5 are used assuming a thick steel plate when calculating the lateral nail load-carrying-capacity for joist hangers 2,0 mm and 2,5 mm. For joist hangers 1,5 mm the Eurocode 5 equations for thin steel plates are applied.

The load bearing capacities of the brackets has been determined based on the use of connector nails 4,0 x 40 mm in accordance with the German national approval for the nails.

The characteristic withdrawal capacity of the nails has to be determined by calculation in accordance with EN 1995-1-1: 2004, paragraph 8.3.2 (head pull-through is not relevant):

$$F_{ax,Rk} = f_{ax,k} \times d \times t_{pen}$$

Where:

$f_{ax,k}$	Characteristic value of the withdrawal parameter in $N/mm^2$
$d$	Nail diameter in mm
$t_{pen}$	Penetration depth of the profiles shank in mm

Based on tests by Versuchsanstalt für Stahl, Holz und Steine, University of Karlsruhe, the characteristic value of the withdrawal resistance for the threaded nails used can be calculated as:

$$f_{ax,k} = 50 \times 10^{-6} \times \sigma_k^2$$

Where:

$\sigma_k$	Characteristic density of the timber in $kg/m^3$
------------	--------------------------------------------------

The shape of the nail directly under the head shall be in the form of a truncated cone with a diameter under the nail head which exceeds the hole diameter.

Further, the joist hangers may be fastened to a concrete structure or steel member by bolts with a diameter of 10 mm in holes with a diameter of 11 mm.

No performance has been determined in relation to ductility of a joint under cyclic testing. The contribution to the performance of structures in seismic zones, therefore, has not been assessed.

No performance has been determined in relation to the joint's stiffness properties - to be used for the analysis of the serviceability limit state.

### 2.7 Related aspects of serviceability

#### 2.7.1 Corrosion protection in service class 1, 2 and 3.

In accordance with ETAG 015 the joist hangers have a zinc coating weight of min Z275. The steel employed is pregalvanized steel Grade DX51D + Z (min Z275) according to EN 10346:2009 with minimum  $R_{eH}$  of 250 MPa, minimum tensile strength  $R_m$  of 330 MPa and minimum ultimate strain  $A_{80}$  of 19 % with tolerances according to EN 10143:1993 or steel grade S320GD Z275 according to EN 10346:2009 with a minimum yield strength  $R_e$  of 320 MPa, a minimum tensile strength  $R_m$  of 390 MPa and a minimum ultimate strain  $A_{80}$  of 17 % or from stainless steel (1.4301, 1.4401, 1.4541, 1.4571 or 1.4016 according to EN 10088) with equivalent characteristics.

### 3 Attestation of Conformity and CE marking

#### 3.1 Attestation of Conformity system

The system of attestation of conformity is 2+ described in Council Directive 89/106/EEC (Construction Products Directive) Annex III.

- a) Tasks for the manufacturer:
  - (1) Factory production control,
  - (2) Initial type testing of the product,
- b) Tasks for the notified body:
  - (1) Initial inspection of the factory and the factory production control,
  - (2) Continuous surveillance

#### 3.2 Responsibilities

##### 3.2.1 Tasks of the manufacturer

##### 3.2.1.1 Factory production control

The manufacturer has a factory production control system in the plant and exercises permanent internal control of production. All the elements, requirements and provisions adopted by the manufacturer are documented in a systematic manner in the form of written policies and procedures. This production control system ensures that the product is in conformity with the European Technical Approval.

The manufacturer shall only use raw materials supplied with the relevant inspection documents as laid down in the control plan<sup>1</sup>. The incoming raw materials shall be subject to controls and tests by the manufacturer before acceptance. Check of materials, such as sheet metal, shall include control of the inspection documents presented by suppliers (comparison with nominal values) by verifying dimension and determining material properties, e.g. chemical composition, mechanical properties and zinc coating thickness.

The manufactured components are checked visually and for dimensions.

The control plan, which is part of the technical documentation of this European Technical Approval,

<sup>1</sup> The control plan has been deposited at ETA-Danmark and is only made available to the approved bodies involved in the conformity attestation procedure.

includes details of the extent, nature and frequency of testing and controls to be performed within the factory production control and has been agreed between the approval holder and ETA Danmark.

The results of factory production control are recorded and evaluated. The records include at least the following information:

- Designation of the product, basic material and components;
- Type of control or testing;
- Date of manufacture of the product and date of testing of the product or basic material and components;
- Result of control and testing and, if appropriate, comparison with requirements;
- Signature of person responsible for factory production control.

The records shall be presented to ETA Danmark on request.

##### 3.2.1.1 Initial type testing of the product

For initial type-testing the results of the tests performed as part of the assessment for the European Technical Approval shall be used unless there are changes in the production line or plant. In such cases the necessary initial type testing has to be agreed between ETA Danmark and the notified body.

##### 3.2.2. Tasks of notified bodies

##### 3.2.2.1 Initial inspection of the factory and the factory production control

The approved body should ascertain that, in accordance with the control plan, the factory, in particular the staff and equipment, and the factory production control, are suitable to ensure a continuous and orderly manufacturing of the joist hangers with the specifications given in part 2.

##### 3.2.2.2 Continuous surveillance

The approved body shall visit the factory at least once a year for routine inspections. It shall be verified that the system of factory production control and the specified manufacturing processes are maintained, taking account of the control plan.

The results of product certification and continuous surveillance shall be made available on demand by the certification body to ETA Danmark. Where the provisions of the European Technical Approval and the control plan are no longer fulfilled, the certificate

of conformity shall be withdrawn by the approved body.

### **3.3 CE marking**

The CE marking shall be affixed on each packaging of joist hangers. The initials "CE" shall be followed by the identification number of the notified body and shall be accompanied by the following information:

- Name or identifying mark of the manufacturer
- The last two digits of the year in which the marking was affixed
- Number of the European Technical Approval
- Name and size of product
- Number of the ETA Guideline (ETAG no. 015)
- Number of the EC Certificate of Conformity



## 4 Assumptions under which the fitness of the product for the intended use was favourably assessed

### 4.1 Manufacturing

FraP joist hangers are manufactured in accordance with the provisions of this European Technical Approval using the manufacturing processes as identified in the inspection of the plant by the notified inspection body and laid down in the technical documentation.

### 4.2 Installation

#### Joist hanger connections

A joist hanger connection is deemed fit for its intended use provided:

#### Header – support conditions

- The header shall be restrained against rotation and be free from wane under the joist hanger.

If the header carries joists only on one side, the eccentricity moment from the joists  $M_{ec} = R_{joist} (b_{header}/2 + e_{nail})$  shall be considered at the strength verification of the header.

$R_{joist}$  Reaction force from the joists,  
 $b_{header}$  Width of header,  
 $e_{nail}$  Distance from nails in the joist to the surface of the header.

- For a header with joists from both sides but with different reaction forces a similar consideration applies.

#### Wood to wood connections

- Joist hangers may be fastened to wood-based members by nails.
- There shall be nails in all holes or a partial nailing pattern as prescribed in Annex B-C may be used.
- The characteristic capacity of the joist hanger connection is calculated according to the manufacturer's technical documentation, dated 2010-08-13.
- The joist hanger connection is designed in accordance with Eurocode 5 or an appropriate national code.
- The gap between the end of the joist and the surface, where contact stresses can occur during loading shall be limited. This means that the gap between the surface of the end of the joist and that of the header shall not exceed 3 mm.
- For FraP joist hangers with overlapping nails in the joist (see figure 8.5 in EN 1995-1-1) the width of the joist shall be at least  $l + 4d$ , where  $l$  is the length of the nails and  $d$  is the diameter of the nails in the joist. For joist hangers with staggered nails in the joist the

width shall be at least the penetration length of the nails.

- The cross section of the joist at the joist hanger connection shall have sharp edges at the lower side against the bottom plate, i.e. it shall be without wane.
- The cross section of the header shall have a plane surface against the whole joist hanger.
- The width  $B_j$  of the joist shall correspond to that of the joist hanger.  $B_j$  shall not be smaller than  $B - 3$  mm, where  $B$  is the inner width of the joist hanger.
- The depth of the joist shall be so large that the top of the joist is at least 20 mm above the upper fastener in the joist.
- Nails to be used shall have a diameter, which fit the holes of the joist hangers. Nails shall have a diameter which is not smaller than the diameter of the hole minus 1 mm.

#### Wood to concrete or steel

The above mentioned rules for wood to wood connections are applicable also for the connection between the joist and the joist hanger.

- The joist hanger shall be in close contact with the concrete or steel over the whole face. There shall be no intermediate layers in between.
- The gap between the end of the joist and the surface, where contact stresses can occur during loading shall be limited. This means that the gap between the surface of the end of the joist and that of the concrete or steel shall not exceed 3 mm.
- The bolt shall have a diameter not less than the hole diameter minus 2 mm.
- The bolts shall be placed symmetrically about the vertical symmetry line. There shall always be bolts in the 2 upper holes.
- The upper bolts shall have washers according to EN ISO 7094.

### 4.3 Maintenance and repair

Maintenance is not required during the assumed intended working life. Should repair prove necessary, it is normal to replace the joist hanger.

Thomas Bruun  
 Manager, ETA-Danmark

**Annex A**  
**Product details and definitions**

**Joist hanger type Kombi Blank 220/240:** Face mount hanger with external flanges

2,0 mm thick pre-galvanized steel Grade DX51D + Z (min Z275) according to EN 10346:2009 with minimum  $R_{eH}$  of 250 MPa, minimum tensile strength  $R_m$  of 330 MPa and minimum ultimate strain  $A_{80}$  of 19 % with tolerances according to EN 10143:1993 or steel grade S320GD Z275 according to EN 10346:2009 with a minimum yield strength  $R_e$  of 320 MPa, a minimum tensile strength  $R_m$  of 390 MPa and a minimum ultimate strain  $A_{80}$  of 17 % or from stainless steel (1.4301, 1.4401, 1.4541, 1.4571 or 1.4016 according to EN 10088) with equivalent characteristics.

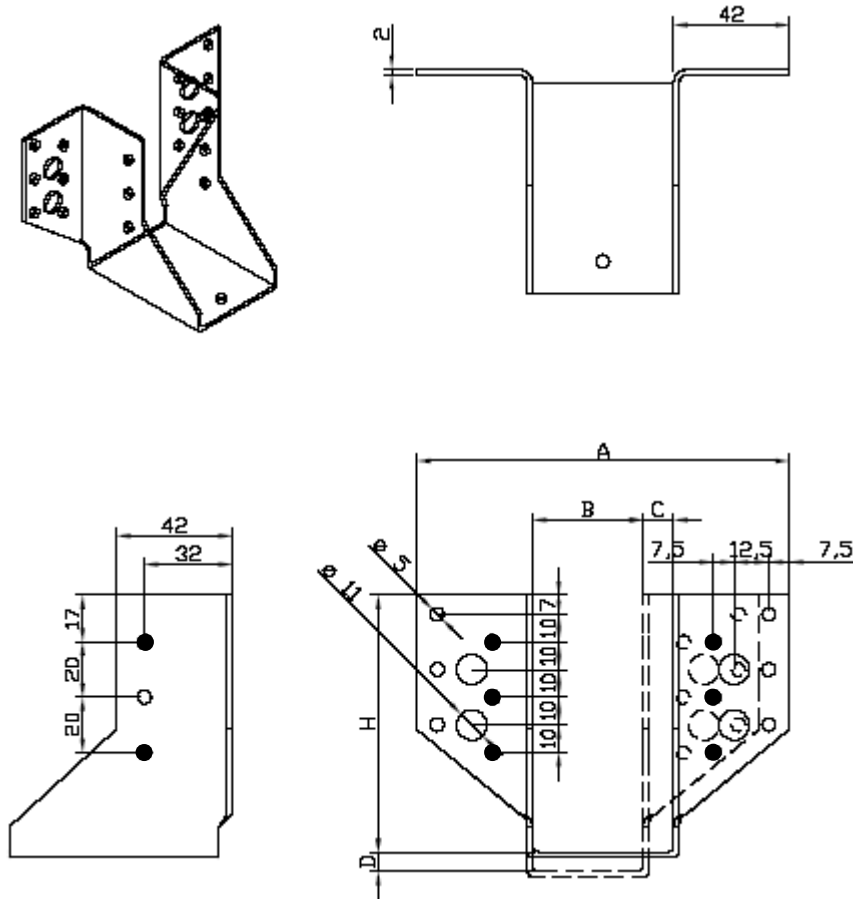

- Partial nailing; For  $B \leq 50$  mm staggered joist nailing; Drawing: Blank length 240 mm

Blank	Total n° of holes		Width interval		Height interval	
	$n_H$	$n_J$	min	max	min	max
220	10	6	60	60	80	80
240	12	6	40	51	93	100

Joist hanger's height = (blank – width)/2

**Joist hanger type Kombi Blank 260/280:** Face mount hanger with external flanges

2,0 mm thick pre-galvanized steel Grade DX51D + Z (min Z275) according to EN 10346:2009 with minimum  $R_{eH}$  of 250 MPa, minimum tensile strength  $R_m$  of 330 MPa and minimum ultimate strain  $A_{80}$  of 19 % with tolerances according to EN 10143:1993 or steel grade S320GD Z275 according to EN 10346:2009 with a minimum yield strength  $R_e$  of 320 MPa, a minimum tensile strength  $R_m$  of 390 MPa and a minimum ultimate strain  $A_{80}$  of 17 % or from stainless steel (1.4301, 1.4401, 1.4541, 1.4571 or 1.4016 according to EN 10088) with equivalent characteristics.

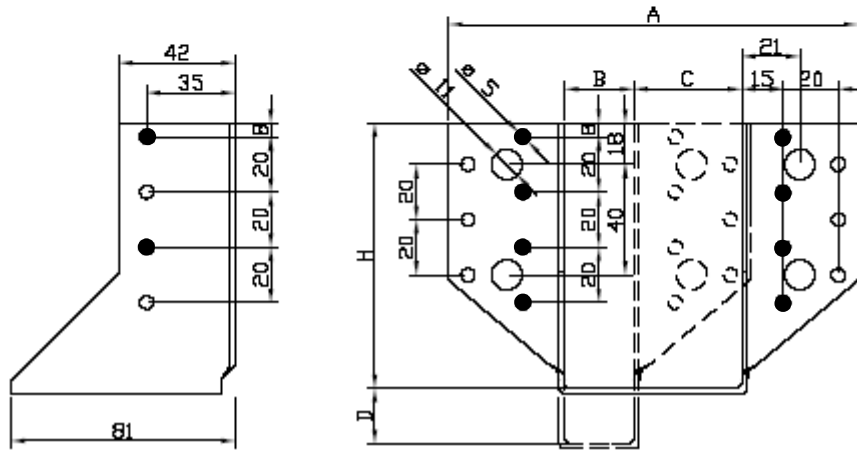
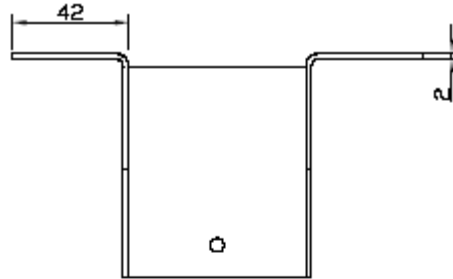
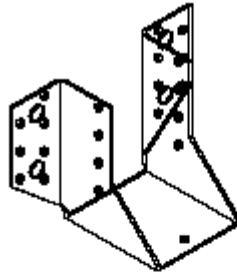

- Partial nailing; For  $B \leq 50$  mm staggered joist nailing; Drawing: Blank length 260 mm

Blank	Total n° of holes		Width interval		Height interval	
	$n_H$	$n_I$	min	max	min	max
260	14	8	25	64	98	118
280	14	8	80	80	100	100

Joist hanger's height = (blank – width)/2

**Joist hanger type Kombi Blank 300/320/340:** Face mount hanger with external flanges

2,0 mm thick pre-galvanized steel Grade DX51D + Z (min Z275) according to EN 10346:2009 with minimum  $R_{eH}$  of 250 MPa, minimum tensile strength  $R_m$  of 330 MPa and minimum ultimate strain  $A_{80}$  of 19 % with tolerances according to EN 10143:1993 or steel grade S320GD Z275 according to EN 10346:2009 with a minimum yield strength  $R_e$  of 320 MPa, a minimum tensile strength  $R_m$  of 390 MPa and a minimum ultimate strain  $A_{80}$  of 17 % or from stainless steel (1.4301, 1.4401, 1.4541, 1.4571 or 1.4016 according to EN 10088) with equivalent characteristics.

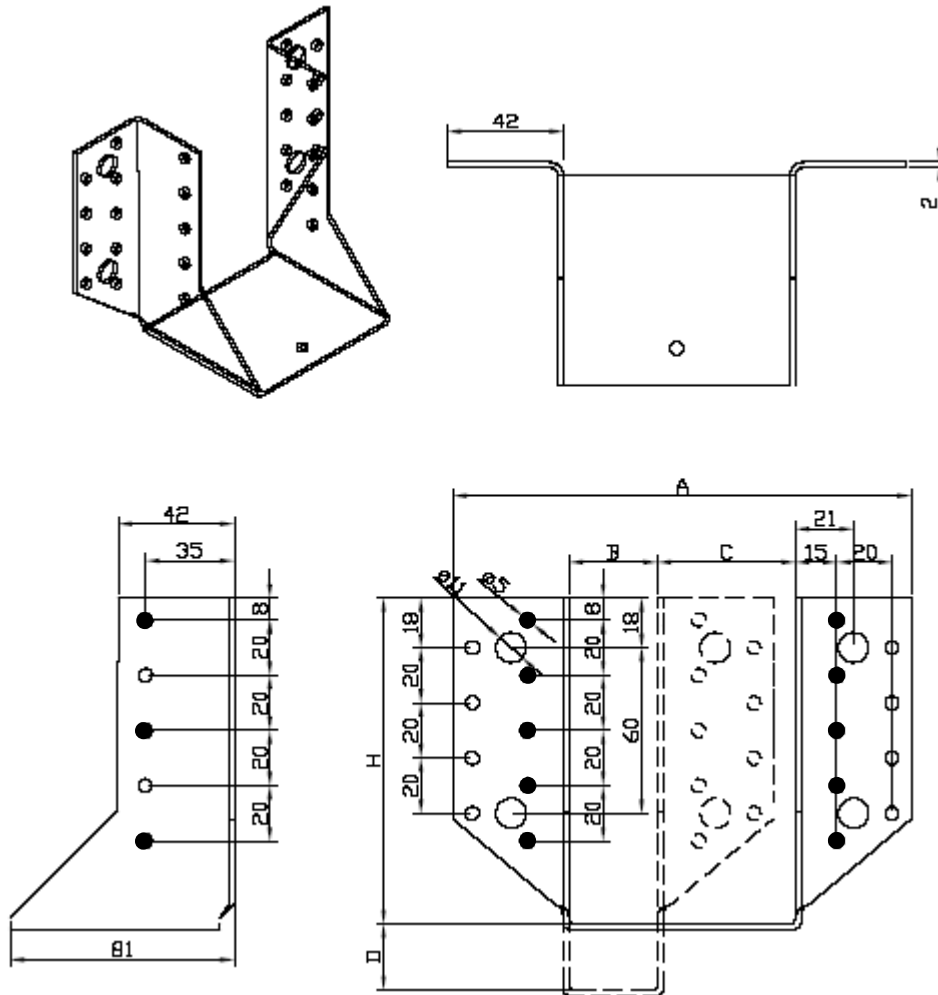

- Partial nailing; For  $B \leq 50$  mm staggered joist nailing; Drawing: Blank length 320 mm

Blank	Total n° of holes		Width interval		Height interval	
	$n_H$	$n_V$	min	max	min	max
300	18	10	60	60	120	120
320	18	10	32	80	120	144
340	18	10	100	100	120	120

Joist hanger's height = (blank – width)/2

**Joist hanger type Kombi Blank 360/380/400:** Face mount hanger with external flanges

2,0 mm thick pre-galvanized steel Grade DX51D + Z (min Z275) according to EN 10346:2009 with minimum  $R_{eH}$  of 250 MPa, minimum tensile strength  $R_m$  of 330 MPa and minimum ultimate strain  $A_{80}$  of 19 % with tolerances according to EN 10143:1993 or steel grade S320GD Z275 according to EN 10346:2009 with a minimum yield strength  $R_e$  of 320 MPa, a minimum tensile strength  $R_m$  of 390 MPa and a minimum ultimate strain  $A_{80}$  of 17 % or from stainless steel (1.4301, 1.4401, 1.4541, 1.4571 or 1.4016 according to EN 10088) with equivalent characteristics.

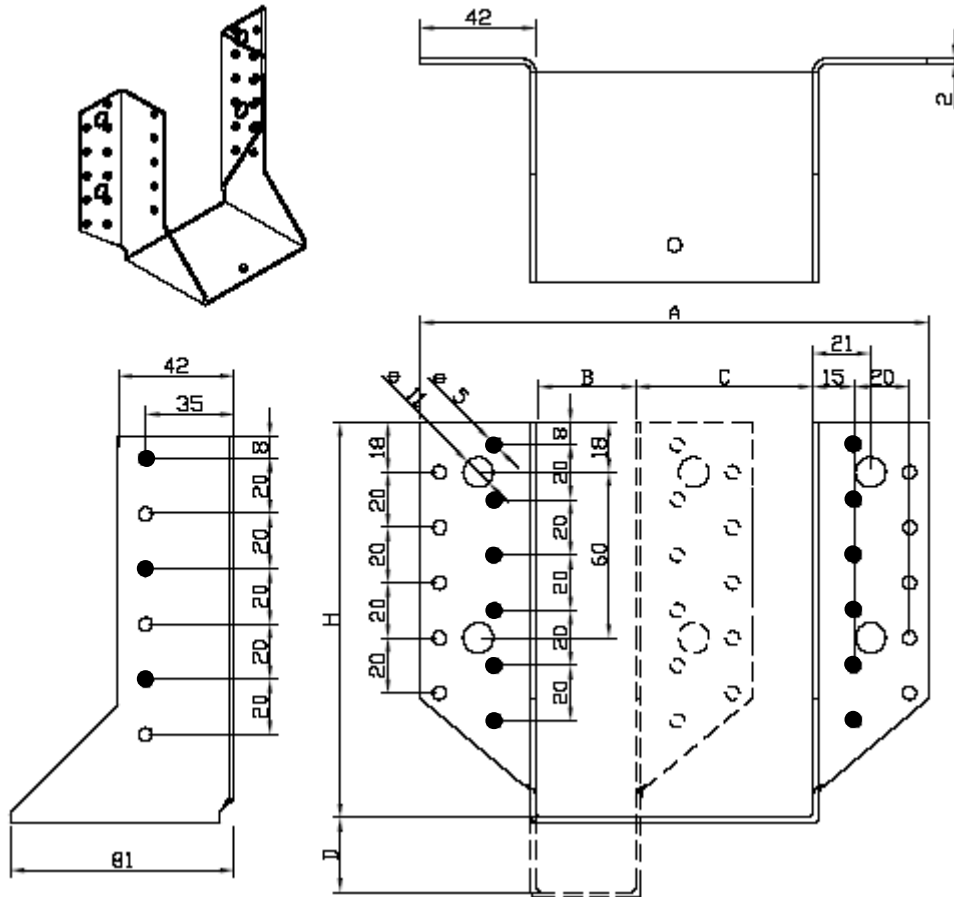

- Partial nailing; For  $B \leq 50$  mm staggered joist nailing; Drawing: Blank length 380 mm

Blank	Total n° of holes		Width interval		Height interval	
	$n_H$	$n_I$	min	max	min	max
360	22	12	80	80	140	140
380	22	12	36	100	140	172
400	22	12	120	120	140	140

Joist hanger's height = (blank – width)/2

**Joist hanger type Kombi Blank 420/440/460:** Face mount hanger with external flanges

2,0 mm thick pre-galvanized steel Grade DX51D + Z (min Z275) according to EN 10346:2009 with minimum  $R_{eH}$  of 250 MPa, minimum tensile strength  $R_m$  of 330 MPa and minimum ultimate strain  $A_{80}$  of 19 % with tolerances according to EN 10143:1993 or steel grade S320GD Z275 according to EN 10346:2009 with a minimum yield strength  $R_e$  of 320 MPa, a minimum tensile strength  $R_m$  of 390 MPa and a minimum ultimate strain  $A_{80}$  of 17 % or from stainless steel (1.4301, 1.4401, 1.4541, 1.4571 or 1.4016 according to EN 10088) with equivalent characteristics.

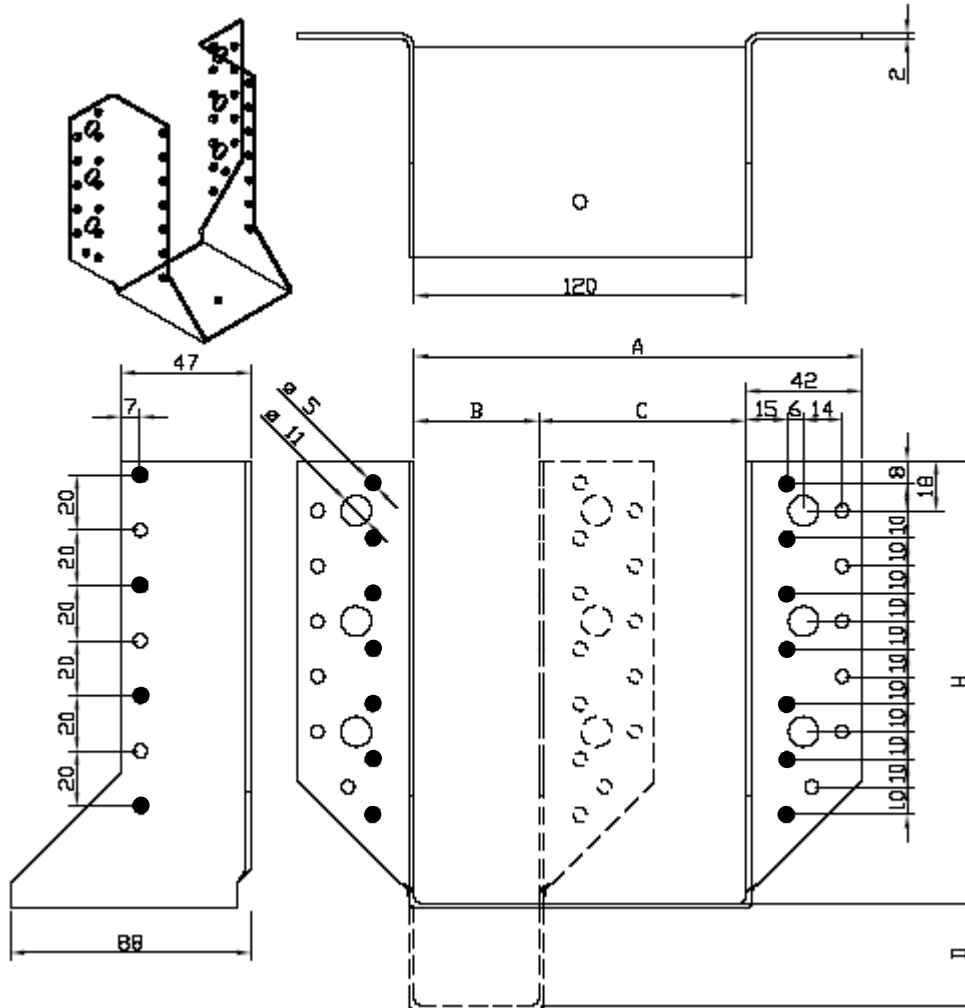

- Partial nailing; For  $B \leq 50$  mm staggered joist nailing; Drawing: Blank length 440 mm

Blank	Total n° of holes		Width interval		Height interval	
	$n_H$	$n_J$	min	max	min	max
420	26	14	100	100	160	160
440	26	14	45	120	160	197
460	26	14	140	140	160	160

Joist hanger's height = (blank – width)/2

**Joist hanger type Kombi Blank 500/540:** Face mount hanger with external flanges

2,0 mm thick pre-galvanized steel Grade DX51D + Z (min Z275) according to EN 10346:2009 with minimum  $R_{eH}$  of 250 MPa, minimum tensile strength  $R_m$  of 330 MPa and minimum ultimate strain  $A_{80}$  of 19 % with tolerances according to EN 10143:1993 or steel grade S320GD Z275 according to EN 10346:2009 with a minimum yield strength  $R_e$  of 320 MPa, a minimum tensile strength  $R_m$  of 390 MPa and a minimum ultimate strain  $A_{80}$  of 17 % or from stainless steel (1.4301, 1.4401, 1.4541, 1.4571 or 1.4016 according to EN 10088) with equivalent characteristics.

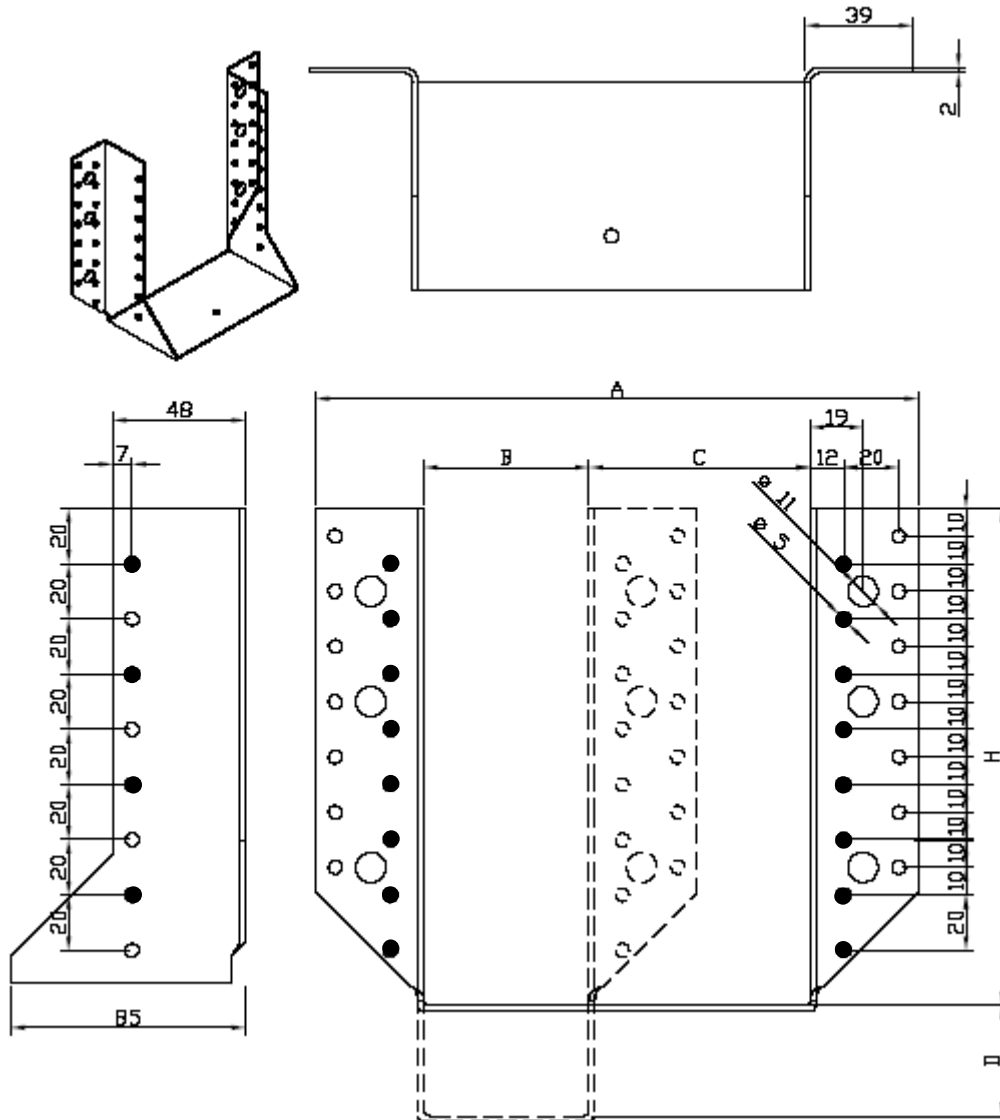

- Partial nailing; For  $B \leq 50$  mm staggered joist nailing; Drawing: Blank length 500 mm

Blank	Total n° of holes		Width interval		Height interval	
	$n_H$	$n_I$	min	max	min	max
500	30	16	60	140	180	220
540	34	18	140	140	200	200

Joist hanger's height = (blank – width)/2

**Joist hanger type innen blank 240:** Face mount hanger with interior flanges

2,0 mm thick pre-galvanized steel Grade DX51D + Z (min Z275) according to EN 10346:2009 with minimum  $R_{eH}$  of 250 MPa, minimum tensile strength  $R_m$  of 330 MPa and minimum ultimate strain  $A_{80}$  of 19 % with tolerances according to EN 10143:1993 or steel grade S320GD Z275 according to EN 10346:2009 with a minimum yield strength  $R_e$  of 320 MPa, a minimum tensile strength  $R_m$  of 390 MPa and a minimum ultimate strain  $A_{80}$  of 17 % or from stainless steel (1.4301, 1.4401, 1.4541, 1.4571 or 1.4016 according to EN 10088) with equivalent characteristics.

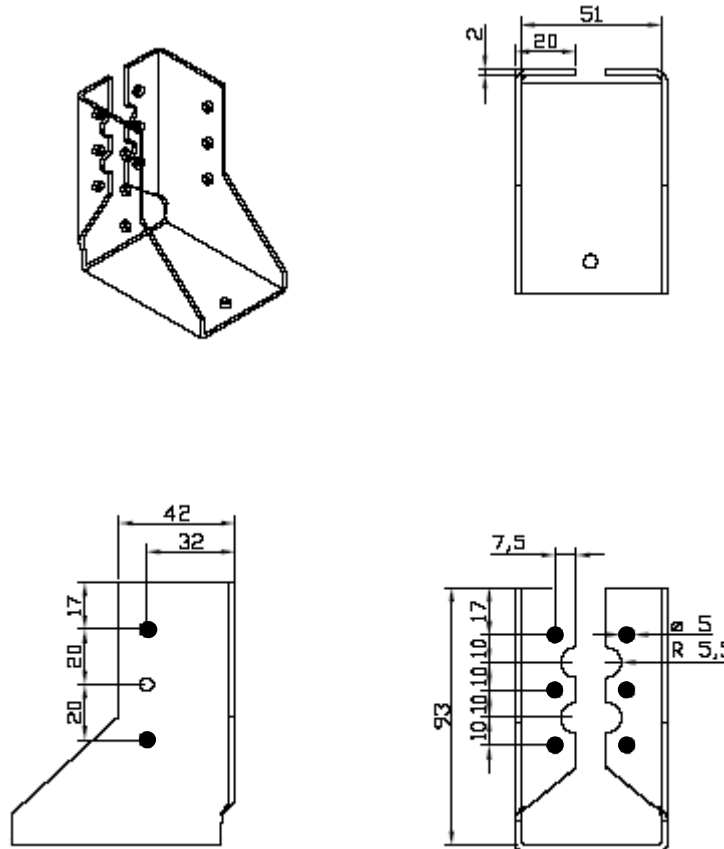

- Partial nailing; For  $B \leq 50$  mm staggered joist nailing; Drawing: Joist hanger 51 x 93

Blank	Total n° of holes		Width interval		Height interval	
	$n_H$	$n_J$	min	max	min	max
240	6	6	45	51	93	96

Joist hanger's height = (blank – width)/2



**Joist hanger type innen blank 260:** Face mount hanger with interior flanges

2,0 mm thick pre-galvanized steel Grade DX51D + Z (min Z275) according to EN 10346:2009 with minimum  $R_{eH}$  of 250 MPa, minimum tensile strength  $R_m$  of 330 MPa and minimum ultimate strain  $A_{80}$  of 19 % with tolerances according to EN 10143:1993 or steel grade S320GD Z275 according to EN 10346:2009 with a minimum yield strength  $R_e$  of 320 MPa, a minimum tensile strength  $R_m$  of 390 MPa and a minimum ultimate strain  $A_{80}$  of 17 % or from stainless steel (1.4301, 1.4401, 1.4541, 1.4571 or 1.4016 according to EN 10088) with equivalent characteristics.

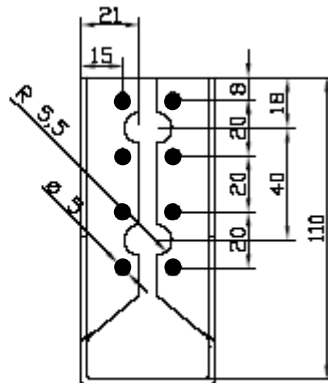
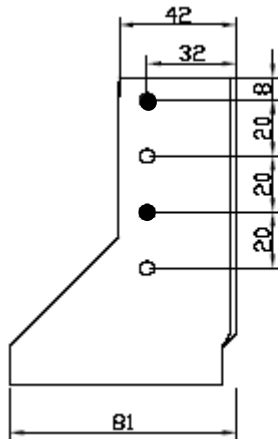
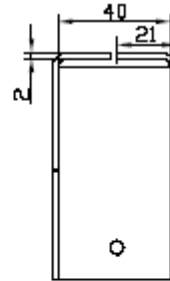

- Partial nailing; For  $B \leq 50$  mm staggered joist nailing; Drawing: Joist hanger 40 x 110

Blank	Total n° of holes		Width interval		Height interval	
	$n_H$	$n_J$	min	max	min	max
260	8	8	40	64	98	110

Joist hanger's height = (blank – width)/2

**Joist hanger type innen blank 320:** Face mount hanger with interior flanges

2,0 mm thick pre-galvanized steel Grade DX51D + Z (min Z275) according to EN 10346:2009 with minimum  $R_{eH}$  of 250 MPa, minimum tensile strength  $R_m$  of 330 MPa and minimum ultimate strain  $A_{80}$  of 19 % with tolerances according to EN 10143:1993 or steel grade S320GD Z275 according to EN 10346:2009 with a minimum yield strength  $R_e$  of 320 MPa, a minimum tensile strength  $R_m$  of 390 MPa and a minimum ultimate strain  $A_{80}$  of 17 % or from stainless steel (1.4301, 1.4401, 1.4541, 1.4571 or 1.4016 according to EN 10088) with equivalent characteristics.

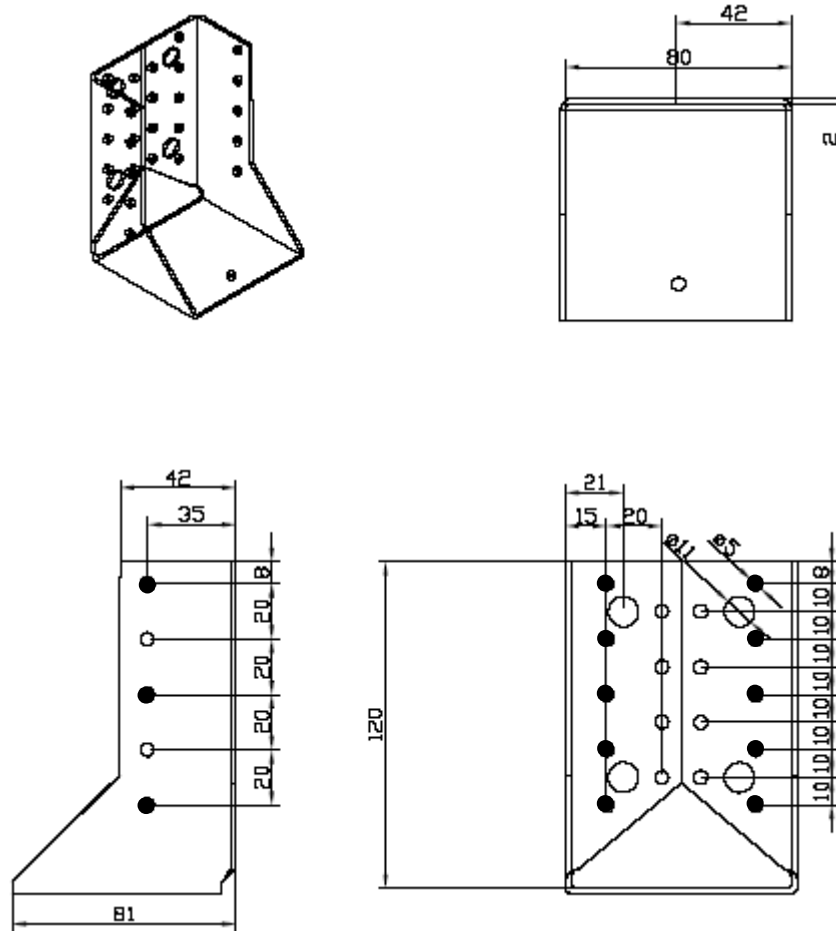

- Partial nailing; For  $B \leq 50$  mm staggered joist nailing; Drawing: Joist hanger 80 x 120

Blank	Total n° of holes		Width interval		Height interval	
	$n_H$	$n_J$	min	max	min	max
320	10/18	10	40	80	120	140

Joist hanger's height = (blank – width)/2

**Joist hanger type innen blank 380:** Face mount hanger with interior flanges

2,0 mm pre-galvanized steel Grade DX51D + Z (min Z275) according to EN 10346:2009 with minimum  $R_{eH}$  of 250 MPa, minimum tensile strength  $R_m$  of 330 MPa and minimum ultimate strain  $A_{80}$  of 19 % with tolerances according to EN 10143:1993 or steel grade S320GD Z275 according to EN 10346:2009 with a minimum yield strength  $R_e$  of 320 MPa, a minimum tensile strength  $R_m$  of 390 MPa and a minimum ultimate strain  $A_{80}$  of 17 % or from stainless steel (1.4301, 1.4401, 1.4541, 1.4571 or 1.4016 according to EN 10088) with equivalent characteristics.

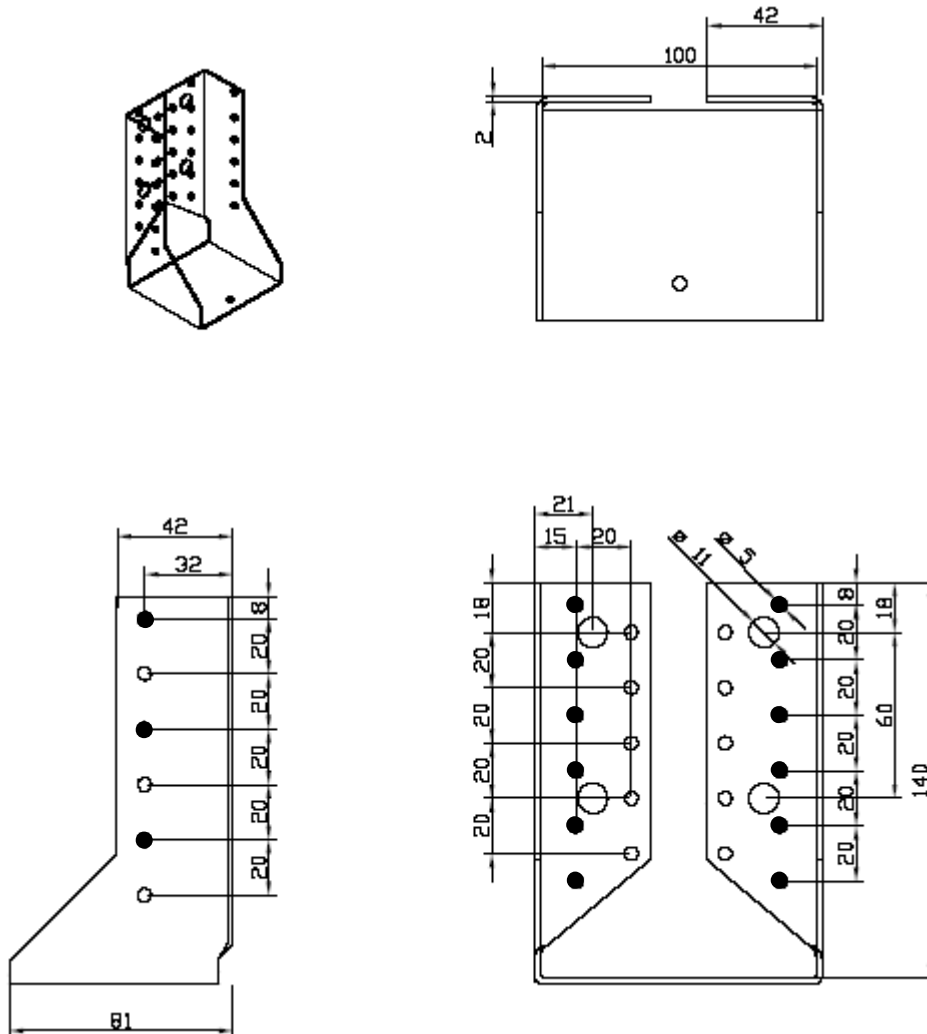

- Partial nailing; For  $B \leq 50$  mm staggered joist nailing; Drawing: Joist hanger 100 x 140

Blank	Total n° of holes		Width interval		Height interval	
	$n_H$	$n_I$	min	max	min	max
380	12/22	12	45	100	140	167

Joist hanger's height = (blank – width)/2

**Joist hanger type innen blank 440:** Face mount hanger with interior flanges

2,0 mm thick pre-galvanized steel Grade DX51D + Z (min Z275) according to EN 10346:2009 with minimum  $R_{eH}$  of 250 MPa, minimum tensile strength  $R_m$  of 330 MPa and minimum ultimate strain  $A_{80}$  of 19 % with tolerances according to EN 10143:1993 or steel grade S320GD Z275 according to EN 10346:2009 with a minimum yield strength  $R_e$  of 320 MPa, a minimum tensile strength  $R_m$  of 390 MPa and a minimum ultimate strain  $A_{80}$  of 17 % or from stainless steel (1.4301, 1.4401, 1.4541, 1.4571 or 1.4016 according to EN 10088) with equivalent characteristics.

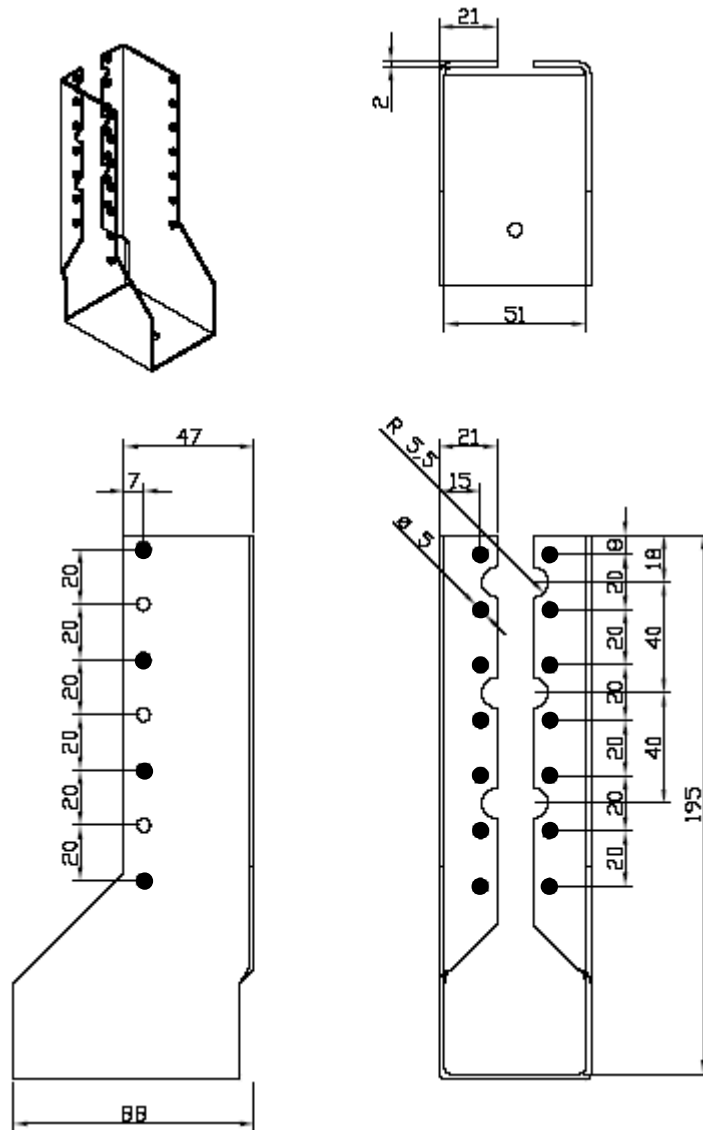

- Partial nailing; For  $B \leq 50$  mm staggered joist nailing; Drawing: Joist hanger 51 x 195

Blank	Total n° of holes		Width interval		Height interval	
	$n_H$	$n_I$	min	max	min	max
440	14/26	14	45	120	160	197

Joist hanger's height = (blank – width)/2

**Joist hanger type innen blank 500:** Face mount hanger with interior flanges

2,0 mm thick pre-galvanized steel Grade DX51D + Z (min Z275) according to EN 10346:2009 with minimum  $R_{eH}$  of 250 MPa, minimum tensile strength  $R_m$  of 330 MPa and minimum ultimate strain  $A_{80}$  of 19 % with tolerances according to EN 10143:1993 or steel grade S320GD Z275 according to EN 10346:2009 with a minimum yield strength  $R_e$  of 320 MPa, a minimum tensile strength  $R_m$  of 390 MPa and a minimum ultimate strain  $A_{80}$  of 17 % or from stainless steel (1.4301, 1.4401, 1.4541, 1.4571 or 1.4016 according to EN 10088) with equivalent characteristics.

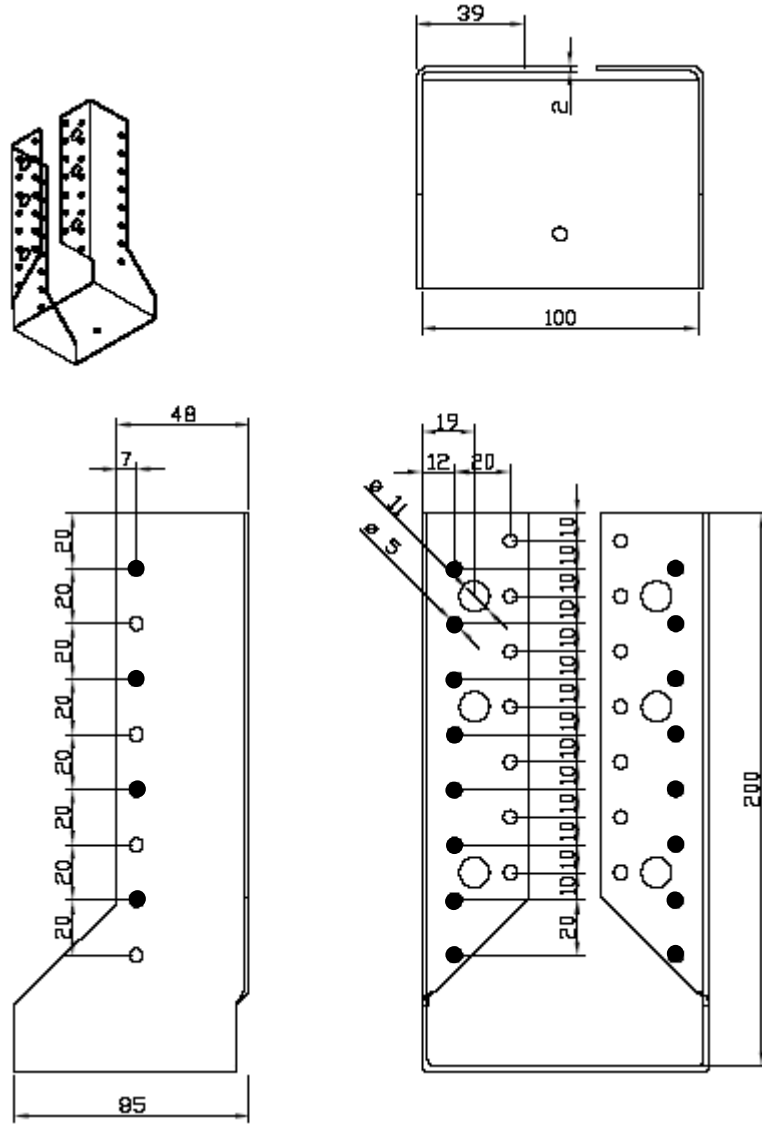

- Partial nailing; For  $B \leq 50$  mm staggered joist nailing; Drawing: Joist hanger 100 x 200

Blank	Total n° of holes		Width interval		Height interval	
	$n_H$	$n_I$	min	max	min	max
500	30	16	100	140	180	200

Joist hanger's height = (blank – width)/2

**Joist hanger:** Face mount hanger with external flanges

2,5 mm thick pre-galvanized steel Grade DX51D + Z (min Z275) according to EN 10346:2009 with minimum  $R_{eH}$  of 250 MPa, minimum tensile strength  $R_m$  of 330 MPa and minimum ultimate strain  $A_{80}$  of 19 % with tolerances according to EN 10143:1993 or steel grade S320GD Z275 according to EN 10346:2009 with a minimum yield strength  $R_e$  of 320 MPa, a minimum tensile strength  $R_m$  of 390 MPa and a minimum ultimate strain  $A_{80}$  of 17 % or from stainless steel (1.4301, 1.4401, 1.4541, 1.4571 or 1.4016 according to EN 10088) with equivalent characteristics.

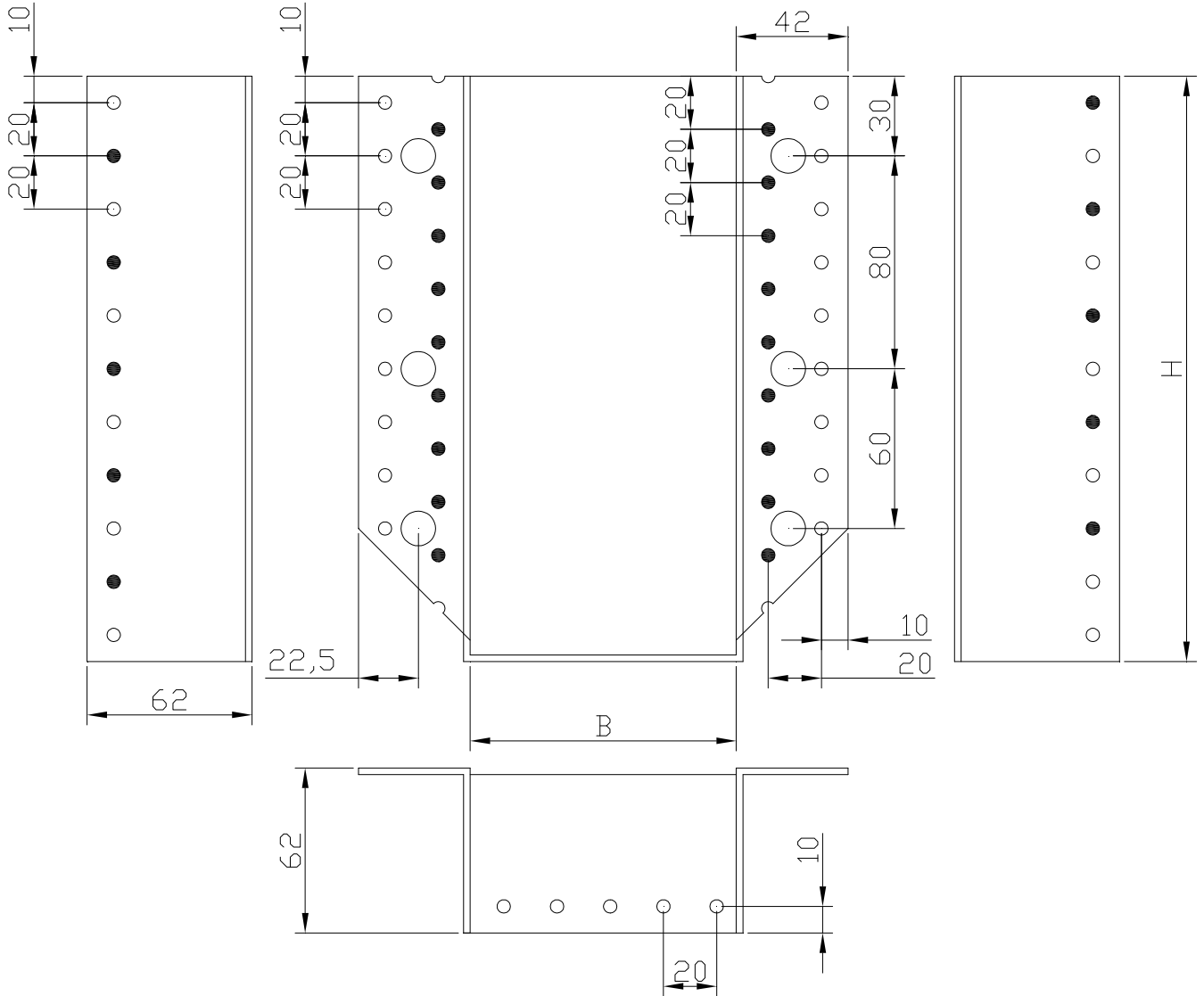

- Partial nailing; For  $B \leq 50$  mm staggered joist nailing; Drawing: Blank length 540 mm

Blank	Type	Total n° of holes for full nailing		Total n° of holes for partial nailing		Width interval		Height interval	
		$n_H$	$n_J$	$n_H$	$n_J$	min	max	min	max
540	100 x 220	36	20	18	10	51	100	220	245
580	100 x 240	40	22	20	11	51	100	240	265
620	100 x 260	44	24	22	12	51	100	260	285
660	100 x 280	48	26	24	13	51	100	280	305
700	100 x 300	52	28	26	14	51	100	300	325
740	100 x 320	56	30	28	15	51	100	320	345
480	120 x 180	28	16	14	8	51	120	180	215
520	120 x 200	32	18	16	9	51	120	200	235
560	120 x 220	36	20	18	10	51	120	220	255
600	120 x 240	40	22	20	11	51	120	240	275
640	120 x 260	44	24	22	12	51	120	260	295
680	120 x 280	48	26	24	13	51	120	280	315
720	120 x 300	52	28	26	14	51	120	300	335
760	120 x 320	56	30	28	15	51	120	320	355

500	140 x 180	28	16	14	8	51	140	180	225
540	140 x 200	32	18	16	9	51	140	200	245
580	140 x 220	36	20	18	10	51	140	220	265
620	140 x 240	40	22	20	11	51	140	240	285
660	140 x 260	44	24	22	12	51	140	260	305
700	140 x 280	48	26	24	13	51	140	280	325
740	140 x 300	52	28	26	14	51	140	300	345
780	140 x 320	56	30	28	15	51	140	320	365
560	160 x 200	32	18	16	9	51	160	200	255
600	160 x 220	36	20	18	10	51	160	220	275
640	160 x 240	40	22	20	11	51	160	240	295
680	160 x 260	44	24	22	12	51	160	260	315
720	160 x 280	48	26	24	13	51	160	280	335
760	160 x 300	52	28	26	14	51	160	300	355
800	160 x 320	56	30	28	15	51	160	320	375
620	180 x 220	36	20	18	10	51	180	220	285
660	180 x 240	40	22	20	11	51	180	240	305
700	180 x 260	44	24	22	12	51	180	260	325
740	180 x 280	48	26	24	13	51	180	280	345
780	180 x 300	52	28	26	14	51	180	300	365
820	180 x 320	56	30	28	15	51	180	320	385
640	200 x 220	36	20	18	10	51	200	220	295
680	200 x 240	40	22	20	11	51	200	240	315
720	200 x 260	44	24	22	12	51	200	260	335
760	200 x 280	48	26	24	13	51	200	280	355
800	200 x 300	52	28	26	14	51	200	300	375
840	200 x 320	56	30	28	15	51	200	320	395
660	220 x 220	36	20	18	10	51	220	220	305
700	220 x 240	40	22	20	11	51	220	240	325
740	220 x 260	44	24	22	12	51	220	260	345
780	220 x 280	48	26	24	13	51	220	280	365
820	220 x 300	52	28	26	14	51	220	300	385
860	220 x 320	56	30	28	15	51	220	320	405

Joist hanger's height = (blank – width)/2

**Fastener types and sizes**

<b>NAIL diameter</b>	<b>Length Min – max</b>	<b>Nail type</b>
4.0	35 - 100	Ringed shank nails according to EN 14592

<b>BOLT diameter</b>	<b>Corresponding hole diameter</b>	<b>Bolt type</b>
10.0	11.0	See specification of the manufacturer



## Annex B

### Characteristic load-carrying-capacities

#### Characteristic capacities of the joist hanger connections with nails

The downward and the upward directed forces are assumed to act in the middle of the joist. The lateral force is assumed to act at a distance  $e_{J,90}$  above the centre of gravity of the nails in the joist.

Two nail patterns are specified. A full nailing pattern, where there are nails in all the holes, and a partial nailing pattern, where the number of nails in the joist and the header are at least half the numbers specified for full nailing. The nails in the joist may be staggered and there shall always be a nail in the upper and the lower holes. The other nails are distributed evenly over the height. The nails in the header shall be put in the holes closest to the bend line.

For joist hangers with overlapping nails in the joist (see figure 8.5 in EN 1995-1-1) the width of the joist shall be at least  $l+4d$ , where  $l$  is the length of the nails and  $d$  is the diameter of the nails in the joist. For joist hangers with staggered nails in the joist the width shall be at least the penetration length of the nails.

#### B.1 Joist hangers fastened with nails

##### Force downward toward the bottom plate:

$$F_{Z,Rk} = \min \left\{ \frac{(n_J + 2) \cdot F_{v,J,Rk}}{\sqrt{\left(\frac{1}{n_H \cdot F_{v,H,Rk}}\right)^2 + \left(\frac{1}{k_{H,1} \cdot F_{ax,H,Rk}}\right)^2}} \right. \quad (B.1.1)$$

##### Force upward away from the bottom plate:

$$F_{Z,Rk} = \min \left\{ \frac{n_J \cdot F_{v,J,Rk}}{\sqrt{\left(\frac{1}{n_H \cdot F_{v,H,Rk}}\right)^2 + \left(\frac{1}{k_{H,2} \cdot F_{ax,H,Rk}}\right)^2}} \right. \quad (B.1.2)$$

##### Lateral force

$$F_{Y,Rk} = \min \left\{ \frac{n_J \cdot F_{v,J,Rk}}{\sqrt{\left(\frac{2 \cdot \sqrt{e_{J,0}^2 + e_{J,90}^2}}{B}\right)^2 + \left(\frac{F_{v,J,Rk}}{F_{ax,J,Rk}}\right)^2}} \right. \quad (B.1.3)$$

$$\left. \frac{F_{v,H,Rk}}{\sqrt{\left(\frac{1}{n_H} + \frac{e_H}{e_1}\right)^2 + \left(\frac{e_H}{e_2}\right)^2}} \right\}$$

$n_J$  total number of nails in both sides of the joist

$n_H$  total number of nails in the side of the header

$F_{v,Rk}$  characteristic lateral load-carrying capacity of a nail in the joist or in the header indicated by the indices J or H in N, for 2,0 mm or 2,5 mm steel plates, the Eurocode 5 equations for thick steel plates may be applied

$F_{ax,Rk}$  characteristic axial load-carrying capacity of a nail in the joist or in the header indicated by the indices J or H in N

$B$  width of the joist hanger in mm, see figure B1

$e_{J,90}$  distance of the lateral force above the centre of gravity of the nails in the joist in mm, see Tables B1 to B49.  $e_{J,90}$  must not be taken less than 0,2 times the depth of the joist hanger

$e_{J,0}$  joist hanger dimension in mm, see Tables B1 to B49

$e_1$  joist hanger dimension in mm, see Tables B1 to B49

$e_2$  joist hanger dimension in mm, see Tables B1 to B49

$k_{H,1}$  form factor, see Tables B1 to B49

$k_{H,2}$  form factor, see Tables B1 to B49

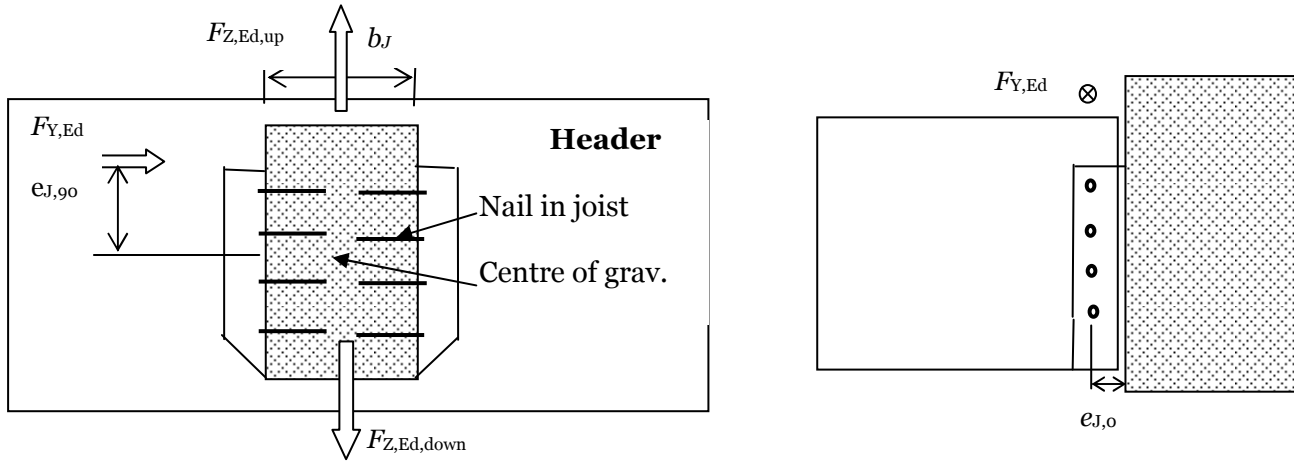

Figure B1: Definition of  $e_{J,90}$  and  $e_{J,0}$

### Combined forces

In case of combined forces the relevant of the following inequalities shall be fulfilled:

Downward force: 
$$\left( \frac{F_{\text{Down,Ed}}}{F_{\text{Down,Rk}}} \right)^2 + \left( \frac{F_{\text{lat,Ed}}}{F_{\text{lat,Rk}}} \right)^2 \leq 1,0 \quad (\text{B.1.4})$$

Upward force: 
$$\left( \frac{F_{\text{Up,Ed}}}{F_{\text{Up,Rk}}} \right)^2 + \left( \frac{F_{\text{lat,Ed}}}{F_{\text{lat,Rk}}} \right)^2 \leq 1,0 \quad (\text{B.1.5})$$

Table B1: Joist hanger type Kombi with external flanges: Form factors  $k_{H,1}$  and  $k_{H,2}$  and dimensions  $e_1$ ,  $e_2$  and  $e_{J,0}$ 

B [mm]	H [mm]	full nailing							partial nailing						
		$n_H$	$n_J$	$k_{H,1}$	$k_{H,2}$	$e_1$ [mm]	$e_2$ [mm]	$e_{J,0}$ [mm]	$n_H$	$n_J$	$k_{H,1}$	$k_{H,2}$	$e_1$ [mm]	$e_2$ [mm]	$e_{J,0}$ [mm]
60	80	10	6	10,2	2,98	1526	473	32	6	4	6,30	1,98	539	303	32
40	100	12	6	16,5	2,33	1139	522	32	6	4	7,90	1,71	350	253	32
45	96	12	6	15,2	2,45	1248	548	32	6	4	7,25	1,81	393	265	32
48	95	12	6	14,9	2,48	1317	563	32	6	4	7,09	1,84	420	273	32
51	93	12	6	14,3	2,55	1388	578	32	6	4	6,77	1,89	448	280	32
25	118	14	8	21,2	5,20	840	530	35	8	4	12,3	3,20	335	365	35
28	116	14	8	20,5	5,31	891	546	35	8	4	12,0	3,27	358	370	35
40	110	14	8	18,5	5,65	1118	610	35	8	4	10,8	3,48	460	394	35
45	105	14	8	16,8	5,98	1223	638	35	8	4	9,85	3,68	508	407	35
48	106	14	8	17,1	5,91	1288	655	35	8	4	10,0	3,64	539	415	35
51	105	14	8	16,8	5,98	1356	672	35	8	4	9,85	3,68	571	423	35
60	100	14	8	15,1	6,34	1572	725	35	8	4	8,93	3,90	673	449	35
64	98	14	8	14,5	6,50	1674	749	35	8	4	8,57	4,00	722	461	35
80	100	14	8	15,1	6,34	2118	847	35	8	4	8,93	3,90	940	513	35
60	120	18	10	22,7	11,4	1651	1016	35	10	6	13,0	6,72	706	628	35
32	144	18	10	32,9	9,25	1060	832	35	10	6	18,6	5,44	440	568	35
36	142	18	10	32,0	9,40	1134	856	35	10	6	18,1	5,53	472	572	35
38	141	18	10	31,6	9,48	1172	868	35	10	6	17,9	5,57	489	575	35
40	140	18	10	31,2	9,56	1211	881	35	10	6	17,6	5,62	506	579	35
45	137	18	10	29,9	9,80	1313	913	35	10	6	16,9	5,76	552	588	35
48	136	18	10	29,4	9,88	1376	933	35	10	6	16,7	5,81	580	595	35
51	135	18	10	29,0	10,0	1442	953	35	10	6	16,4	5,86	610	603	35
60	130	18	10	26,9	10,4	1651	1016	35	10	6	15,3	6,12	706	628	35
64	128	18	10	26,0	10,6	1750	1045	35	10	6	14,8	6,23	752	640	35
70	125	18	10	24,8	10,9	1905	1089	35	10	6	14,1	6,41	825	660	35
73	124	18	10	24,4	11,0	1986	1111	35	10	6	13,9	6,47	863	670	35
76	120	18	10	22,7	11,4	2068	1133	35	10	6	13,5	6,59	902	681	35
80	120	18	10	22,7	11,4	2181	1163	35	10	6	13,0	6,72	956	695	35
100	120	18	10	22,7	11,4	2801	1318	35	10	6	13,0	6,72	1256	773	35
80	140	22	12	31,9	18,0	2291	1527	35	12	6	17,8	10,3	1006	915	35
36	172	22	12	48,2	14,3	1263	1192	35	12	6	26,7	8,16	541	820	35
40	170	22	12	47,2	14,5	1339	1217	35	12	6	26,1	8,27	574	820	35
45	167	22	12	45,6	14,8	1439	1251	35	12	6	25,2	8,44	618	823	35
48	166	22	12	45,0	14,9	1501	1272	35	12	6	25,0	8,49	645	827	35
51	165	22	12	44,5	15,0	1566	1294	35	12	6	24,4	8,61	674	832	35
60	160	22	12	41,4	15,6	1771	1362	35	12	6	23,3	8,85	766	851	35
64	158	22	12	40,9	15,7	1868	1394	35	12	6	22,7	8,98	810	862	35
70	155	22	12	39,3	16,1	2020	1443	35	12	6	21,9	9,18	880	880	35
73	154	22	12	38,8	16,2	2099	1468	35	12	6	21,3	9,31	917	890	35
76	152	22	12	37,8	16,4	2180	1493	35	12	6	21,0	9,38	954	900	35
80	150	22	12	36,8	16,7	2291	1527	35	12	6	20,5	9,52	1006	915	35
86	147	22	12	35,3	17,1	2464	1580	35	12	6	19,7	9,75	1087	937	35
90	145	22	12	34,3	17,3	2584	1615	35	12	6	19,2	9,90	1144	953	35
98	141	22	12	32,3	17,9	2834	1687	35	12	6	18,1	10,2	1263	987	35
100	140	22	12	31,9	18,0	2899	1705	35	12	6	17,8	10,3	1294	995	35
120	140	22	12	31,9	18,0	3595	1892	35	12	6	17,8	10,3	1630	1087	35
100	160	26	14	37,2	22,9	3038	2144	40	14	8	20,5	12,8	1359	1255	40
45	197	26	14	56,5	18,2	1596	1665	40	14	8	30,8	10,2	701	1122	40
51	195	26	14	55,4	18,4	1721	1707	40	14	8	30,2	10,3	756	1120	40
60	190	26	14	52,7	18,9	1924	1776	40	14	8	28,8	10,6	846	1128	40

B [mm]	H [mm]	full nailing							partial nailing						
		n <sub>H</sub>	n <sub>J</sub>	k <sub>H,1</sub>	k <sub>H,2</sub>	e <sub>1</sub> [mm]	e <sub>2</sub> [mm]	e <sub>J,0</sub> [mm]	n <sub>H</sub>	n <sub>J</sub>	k <sub>H,1</sub>	k <sub>H,2</sub>	e <sub>1</sub> [mm]	e <sub>2</sub> [mm]	e <sub>J,0</sub> [mm]
73	184	26	14	49,5	19,6	2248	1886	40	14	8	27,1	11	992	1156	40
76	182	26	14	48,4	19,8	2328	1913	40	14	8	26,5	11,1	1029	1165	40
80	180	26	14	47,4	20,1	2438	1950	40	14	8	25,9	11,2	1079	1177	40
100	170	26	14	42,2	21,4	3038	2144	40	14	8	23,2	12	1359	1255	40
115	162	26	14	38,2	22,6	3544	2299	40	14	8	21,0	12,6	1600	1324	40
120	160	26	14	37,2	22,9	3724	2352	40	14	8	20,5	12,8	1686	1349	40
150	145	26	14	30,1	25,6	4917	2682	40	14	8	16,8	14,3	2263	1509	40
140	160	26	14	37,2	22,9	4498	2570	40	14	8	20,5	12,8	2059	1454	40
60	220	30	16	68,4	20,7	1880	2275	41	16	8	33,9	14,4	824	1472	41
80	210	30	16	62,4	21,7	2331	2428	41	16	8	30,8	15,2	1025	1478	41
90	205	30	16	59,5	22,3	2586	2519	41	16	8	29,3	15,6	1141	1501	41
100	200	30	16	56,6	23,0	2862	2617	41	16	8	27,8	16,1	1268	1534	41
115	190	30	16	50,9	24,3	3312	2776	41	16	8	24,9	17,1	1478	1595	41
120	190	30	16	50,9	24,3	3472	2831	41	16	8	24,9	17,1	1554	1619	41
127	186	30	16	48,7	24,9	3705	2910	41	16	8	23,8	17,5	1664	1653	41
140	180	30	16	45,5	25,8	4163	3061	41	16	8	22,1	18,2	1882	1722	41
140	200	34	18	57,0	34,5	4656	3652	41	18	10	27,8	23,4	2113	2061	41

Table B2: Joist hanger type innen with interior flanges: Form factors k<sub>H,1</sub> and k<sub>H,2</sub> and dimensions e<sub>1</sub>, e<sub>2</sub> and e<sub>J,0</sub>

B [mm]	H [mm]	full nailing							partial nailing						
		n <sub>H</sub>	n <sub>J</sub>	k <sub>H,1</sub>	k <sub>H,2</sub>	e <sub>1</sub> [mm]	e <sub>2</sub> [mm]	e <sub>J,0</sub> [mm]	n <sub>H</sub>	n <sub>J</sub>	k <sub>H,1</sub>	k <sub>H,2</sub>	e <sub>1</sub> [mm]	e <sub>2</sub> [mm]	e <sub>J,0</sub> [mm]
45	96	6	6	7,25	1,81	123	205	32	6	4	7,25	1,81	123	205	32
51	93	6	6	6,77	1,89	148	197	32	6	4	6,77	1,89	148	197	32
40	110	8	8	10,0	4,22	153	539	32	8	4	9,97	4,22	153	539	32
45	105	8	8	10,8	4,02	157	497	32	8	4	10,8	4,02	157	497	32
51	105	8	8	10,8	4,02	175	420	32	8	4	10,8	4,02	175	420	32
60	100	8	8	9,77	4,27	210	371	32	8	4	9,77	4,27	210	371	32
64	98	8	8	9,38	4,38	230	363	32	8	4	9,38	4,38	230	363	32
40	140	10	10	17,6	5,62	212	1213	35	10	6	17,6	5,62	212	1213	35
45	137	10	10	16,9	5,76	223	937	35	10	6	16,9	5,76	223	937	35
48	136	10	10	16,7	5,81	230	837	35	10	6	16,7	5,81	230	837	35
51	135	10	10	16,4	5,86	239	765	35	10	6	16,4	5,86	239	765	35
64	128	10	10	14,6	6,29	290	611	35	10	6	14,3	6,35	290	611	35
70	125	10	10	14,1	6,41	321	584	35	10	6	14,1	6,41	321	584	35
76	120	10	10	13,0	6,72	356	570	35	10	6	13,0	6,72	356	570	35
80	120	18	10	22,7	11,4	492	729	35	10	6	13,0	6,72	382	2184	35
45	167	12	12	27,6	9,23	302	1588	32	12	6	27,6	9,23	302	1588	32
48	166	12	12	27,3	9,29	309	1405	32	12	6	27,3	9,29	309	1405	32
51	164	12	12	26,7	9,42	318	1270	32	12	6	26,7	9,42	318	1270	32
60	160	12	12	25,4	9,68	349	1028	32	12	6	25,4	9,68	349	1028	32
70	155	12	12	23,9	10,0	396	900	32	12	6	23,9	10,0	396	900	32
76	152	12	12	23,0	10,3	430	860	32	12	6	23,0	10,3	430	860	32
80	150	22	12	40,2	18,2	625	1157	32	12	6	22,4	10,4	455	3250	32
90	145	22	12	37,5	18,9	687	1073	32	12	6	21,0	10,8	526	2191	32
100	140	22	12	34,8	19,7	770	1041	32	12	6	19,5	11,3	609	1790	32
45	197	14	14	30,8	10,2	399	2280	40	14	8	30,8	10,2	399	2280	40
51	195	14	14	30,2	10,3	416	1848	40	14	8	30,2	10,3	416	1848	40
60	190	14	14	28,8	10,6	449	1496	40	14	8	28,8	10,6	449	1496	40
73	183	14	14	26,8	11,0	513	1257	40	14	8	26,8	11,0	513	1257	40
76	182	14	14	26,5	11,1	531	1226	40	14	8	26,5	11,1	531	1226	40
80	180	26	14	47,4	20,1	787	1748	40	14	8	25,9	11,2	543	4658	40

B [mm]	H [mm]	full nailing							partial nailing						
		n <sub>H</sub>	n <sub>J</sub>	k <sub>H,1</sub>	k <sub>H,2</sub>	e <sub>1</sub> [mm]	e <sub>2</sub> [mm]	e <sub>J,0</sub> [mm]	n <sub>H</sub>	n <sub>J</sub>	k <sub>H,1</sub>	k <sub>H,2</sub>	e <sub>1</sub> [mm]	e <sub>2</sub> [mm]	e <sub>J,0</sub> [mm]
100	170	26	14	42,2	21,4	928	1505	40	14	8	23,2	12,0	693	2445	40
115	162	26	14	38,2	22,6	1091	1471	40	14	8	21,0	12,6	835	2046	40
120	160	26	14	37,2	22,9	1156	1476	40	14	8	20,5	12,8	889	1975	40
150	145	26	14	29,7	25,8	1660	1607	40	14	8	16,3	14,6	1270	1815	40
100	200	30	16	56,6	23,0	1135	2127	41	16	8	27,8	16,1	789	2960	41
115	190	30	16	50,9	24,3	1302	2056	41	16	8	24,9	17,1	929	2535	41
120	190	30	16	50,9	24,3	1368	2051	41	16	8	24,9	17,1	981	2453	41
140	180	30	16	45,5	25,8	1681	2101	41	16	8	22,1	18,2	1216	2280	41

Table B3: Joist hanger Blank 540 (100 x 220): Form factors k<sub>H,1</sub> and k<sub>H,2</sub> and dimensions e<sub>1</sub> and e<sub>2</sub>; e<sub>J,0</sub> = 52 mm

B [mm]	H [mm]	full nailing							partial nailing						
		n <sub>H</sub>	n <sub>J</sub>	k <sub>H,1</sub>	k <sub>H,2</sub>	e <sub>1</sub> [mm]	e <sub>2</sub> [mm]	n <sub>H</sub>	n <sub>J</sub>	k <sub>H,1</sub>	k <sub>H,2</sub>	e <sub>1</sub> [mm]	e <sub>2</sub> [mm]		
51	245	36	20	68,3	40,4	2138	3160	18	10	33,5	19,6	916	1955		
60	240	36	20	65,8	40,4	2328	3191	18	10	32,3	19,6	997	1899		
62	239	36	20	65,3	40,4	2372	3200	18	10	32,0	19,6	1016	1890		
64	238	36	20	64,7	40,4	2417	3211	18	10	31,7	19,6	1036	1883		
66	237	36	20	64,2	40,4	2464	3222	18	10	31,4	19,6	1056	1877		
68	236	36	20	63,6	40,4	2511	3233	18	10	31,2	19,6	1076	1871		
70	235	36	20	63,1	40,4	2558	3246	18	10	30,9	19,6	1097	1867		
72	234	36	20	62,5	40,4	2607	3259	18	10	30,6	19,6	1118	1864		
73	234	36	20	62,3	40,4	2632	3266	18	10	30,5	19,6	1129	1863		
74	233	36	20	62,0	40,4	2657	3273	18	10	30,4	19,6	1140	1862		
76	232	36	20	61,5	40,4	2707	3287	18	10	30,1	19,6	1163	1860		
78	231	36	20	60,9	40,4	2758	3302	18	10	29,8	19,6	1185	1859		
80	230	36	20	60,4	40,4	2810	3318	18	10	29,5	19,6	1208	1859		
82	229	36	20	59,9	40,4	2863	3334	18	10	29,3	19,6	1232	1860		
84	228	36	20	59,3	40,4	2917	3351	18	10	29,0	19,6	1256	1861		
86	227	36	20	58,8	40,4	2972	3368	18	10	28,7	19,6	1281	1863		
88	226	36	20	58,3	40,4	3027	3386	18	10	28,5	19,6	1306	1865		
90	225	36	20	57,7	40,4	3084	3404	18	10	28,2	19,6	1331	1868		
92	224	36	20	57,2	40,4	3141	3423	18	10	28,0	19,6	1357	1872		
94	223	36	20	56,7	40,4	3199	3442	18	10	27,7	19,6	1383	1876		
96	222	36	20	56,1	40,4	3258	3461	18	10	27,4	19,6	1410	1880		
98	221	36	20	55,6	40,4	3317	3481	18	10	27,2	19,6	1437	1885		
100	220	36	20	55,1	40,4	3378	3502	18	10	26,9	19,6	1465	1890		

Table B4: Joist hanger Blank 580 (100 x 240): Form factors k<sub>H,1</sub> and k<sub>H,2</sub> and dimensions e<sub>1</sub> and e<sub>2</sub>; e<sub>J,0</sub> = 52 mm

B [mm]	H [mm]	full nailing							partial nailing						
		n <sub>H</sub>	n <sub>J</sub>	k <sub>H,1</sub>	k <sub>H,2</sub>	e <sub>1</sub> [mm]	e <sub>2</sub> [mm]	n <sub>H</sub>	n <sub>J</sub>	k <sub>H,1</sub>	k <sub>H,2</sub>	e <sub>1</sub> [mm]	e <sub>2</sub> [mm]		
51	265	40	22	80,8	50,0	2392	3952	20	11	39,7	24,4	1046	2510		
60	260	40	22	78,0	50,0	2581	3954	20	11	38,3	24,4	1125	2411		
62	259	40	22	77,4	50,0	2625	3958	20	11	38,0	24,4	1144	2395		
64	258	40	22	76,8	50,0	2670	3963	20	11	37,7	24,4	1164	2380		
66	257	40	22	76,2	50,0	2716	3969	20	11	37,4	24,4	1183	2367		
68	256	40	22	75,6	50,0	2763	3976	20	11	37,1	24,4	1204	2355		
70	255	40	22	75,0	50,0	2810	3984	20	11	36,8	24,4	1224	2344		
72	254	40	22	74,4	50,0	2859	3994	20	11	36,5	24,4	1245	2335		
73	254	40	22	74,2	50,0	2883	3998	20	11	36,4	24,4	1256	2331		
74	253	40	22	73,9	50,0	2908	4003	20	11	36,2	24,4	1267	2327		
76	252	40	22	73,3	50,0	2958	4014	20	11	35,9	24,4	1289	2320		

B [mm]	H [mm]	full nailing						partial nailing					
		n <sub>H</sub>	n <sub>J</sub>	k <sub>H,1</sub>	k <sub>H,2</sub>	e <sub>1</sub> [mm]	e <sub>2</sub> [mm]	n <sub>H</sub>	n <sub>J</sub>	k <sub>H,1</sub>	k <sub>H,2</sub>	e <sub>1</sub> [mm]	e <sub>2</sub> [mm]
78	251	40	22	72,7	50,0	3009	4026	20	11	35,6	24,4	1311	2314
80	250	40	22	72,1	50,0	3061	4038	20	11	35,3	24,4	1334	2309
82	249	40	22	71,5	50,0	3113	4052	20	11	35,0	24,4	1358	2305
84	248	40	22	70,9	50,0	3167	4065	20	11	34,7	24,4	1381	2302
86	247	40	22	70,3	50,0	3221	4080	20	11	34,4	24,4	1406	2300
88	246	40	22	69,7	50,0	3276	4095	20	11	34,2	24,4	1430	2299
90	245	40	22	69,2	50,0	3332	4111	20	11	33,9	24,4	1455	2298
92	244	40	22	68,6	50,0	3389	4128	20	11	33,6	24,4	1481	2298
94	243	40	22	68,0	50,0	3447	4145	20	11	33,3	24,4	1507	2299
96	242	40	22	67,4	50,0	3505	4163	20	11	33,	24,4	1533	2300
98	241	40	22	66,8	50,0	3565	4181	20	11	32,0	24,4	1560	2302
100	240	40	22	66,3	50,0	3625	4200	20	11	32,4	24,4	1588	2305

Table B5: Joist hanger Blank 620 (100 x 260): Form factors k<sub>H,1</sub> and k<sub>H,2</sub> and dimensions e<sub>1</sub> and e<sub>2</sub>; e<sub>1,0</sub> = 52 mm

B [mm]	H [mm]	full nailing						partial nailing					
		n <sub>H</sub>	n <sub>J</sub>	k <sub>H,1</sub>	k <sub>H,2</sub>	e <sub>1</sub> [mm]	e <sub>2</sub> [mm]	n <sub>H</sub>	n <sub>J</sub>	k <sub>H,1</sub>	k <sub>H,2</sub>	e <sub>1</sub> [mm]	e <sub>2</sub> [mm]
51	285	44	24	94,3	60,6	2674	4883	22	12	46,3	29,6	1189	3172
60	280	44	24	91,3	60,6	2862	4846	22	12	44,8	29,6	1268	3019
62	279	44	24	90,6	60,6	2906	4843	22	12	44,5	29,6	1287	2993
64	278	44	24	90,0	60,6	2951	4841	22	12	44,2	29,6	1306	2968
66	277	44	24	89,3	60,6	2996	4840	22	12	43,9	29,6	1326	2946
68	276	44	24	88,7	60,6	3043	4841	22	12	43,5	29,6	1346	2925
70	275	44	24	88,0	60,6	3090	4843	22	12	43,2	29,6	1366	2906
72	274	44	24	87,4	60,6	3138	4846	22	12	42,9	29,6	1387	2889
73	274	44	24	87,0	60,6	3163	4848	22	12	42,7	29,6	1397	2881
74	273	44	24	86,7	60,6	3187	4850	22	12	42,6	29,6	1408	2874
76	272	44	24	86,1	60,6	3237	4856	22	12	42,2	29,6	1430	2860
78	271	44	24	85,4	60,6	3288	4862	22	12	41,9	29,6	1452	2847
80	270	44	24	84,8	60,6	3339	4870	22	12	41,6	29,6	1475	2836
82	269	44	24	84,1	60,6	3392	4879	22	12	41,3	29,6	1498	2826
84	268	44	24	83,5	60,6	3445	4888	22	12	41,0	29,6	1522	2818
86	267	44	24	82,9	60,6	3499	4899	22	12	40,6	29,6	1546	2810
88	266	44	24	82,2	60,6	3554	4910	22	12	40,3	29,6	1570	2803
90	265	44	24	81,6	60,6	3610	4922	22	12	40,0	29,6	1595	2798
92	264	44	24	81,0	60,6	3666	4935	22	12	39,7	29,6	1620	2793
94	263	44	24	80,3	60,6	3724	4949	22	12	39,4	29,6	1646	2790
96	262	44	24	79,7	60,6	3782	4964	22	12	39,1	29,6	1672	2787
98	261	44	24	79,1	60,6	3841	4979	22	12	38,8	29,6	1699	2785
100	260	44	24	78,4	60,6	3901	4995	22	12	38,4	29,6	1726	2783

Table B6: Joist hanger Blank 660 (100 x 280): Form factors k<sub>H,1</sub> and k<sub>H,2</sub> and dimensions e<sub>1</sub> and e<sub>2</sub>; e<sub>1,0</sub> = 52 mm

B [mm]	H [mm]	full nailing						partial nailing					
		n <sub>H</sub>	n <sub>J</sub>	k <sub>H,1</sub>	k <sub>H,2</sub>	e <sub>1</sub> [mm]	e <sub>2</sub> [mm]	n <sub>H</sub>	n <sub>J</sub>	k <sub>H,1</sub>	k <sub>H,2</sub>	e <sub>1</sub> [mm]	e <sub>2</sub> [mm]
51	305	48	26	109	72,3	2983	5967	24	13	53,5	35,4	1347	3951
60	300	48	26	106	72,3	3170	5881	24	13	51,9	35,4	1425	3732
62	299	48	26	105	72,3	3214	5867	24	13	51,6	35,4	1443	3692
64	298	48	26	104	72,3	3259	5856	24	13	51,2	35,4	1462	3656
66	297	48	26	103	72,3	3304	5846	24	13	50,8	35,4	1482	3622
68	296	48	26	103	72,3	3351	5838	24	13	50,5	35,4	1502	3591
70	295	48	26	102	72,3	3398	5832	24	13	50,1	35,4	1522	3562

B [mm]	H [mm]	full nailing						partial nailing					
		n <sub>H</sub>	n <sub>J</sub>	k <sub>H,1</sub>	k <sub>H,2</sub>	e <sub>1</sub> [mm]	e <sub>2</sub> [mm]	n <sub>H</sub>	n <sub>J</sub>	k <sub>H,1</sub>	k <sub>H,2</sub>	e <sub>1</sub> [mm]	e <sub>2</sub> [mm]
72	294	48	26	101	72,3	3446	5828	24	13	49,8	35,4	1543	3535
73	294	48	26	101	72,3	3470	5826	24	13	49,6	35,4	1553	3523
74	293	48	26	101	72,3	3495	5824	24	13	49,4	35,4	1564	3511
76	292	48	26	99,9	72,3	3544	5823	24	13	49,1	35,4	1585	3488
78	291	48	26	99,2	72,3	3595	5823	24	13	48,7	35,4	1607	3467
80	290	48	26	98,5	72,3	3646	5824	24	13	48,4	35,4	1630	3448
82	289	48	26	97,8	72,3	3698	5826	24	13	48,1	35,4	1653	3430
84	288	48	26	97,1	72,3	3751	5830	24	13	47,7	35,4	1676	3415
86	287	48	26	96,4	72,3	3805	5835	24	13	47,4	35,4	1700	3400
88	286	48	26	95,8	72,3	3860	5841	24	13	47,0	35,4	1724	3387
90	285	48	26	95,1	72,3	3915	5848	24	13	46,7	35,4	1749	3375
92	284	48	26	94,4	72,3	3972	5856	24	13	46,3	35,4	1774	3364
94	283	48	26	93,7	72,3	4029	5865	24	13	46,0	35,4	1799	3355
96	282	48	26	93,0	72,3	4087	5875	24	13	45,7	35,4	1825	3347
98	281	48	26	92,3	72,3	4146	5886	24	13	45,3	35,4	1852	3339
100	280	48	26	91,7	72,3	4205	5898	24	13	45,0	35,4	1879	3333

Table B7: Joist hanger Blank 700 (100 x 300): Form factors k<sub>H,1</sub> and k<sub>H,2</sub> and dimensions e<sub>1</sub> and e<sub>2</sub>; e<sub>J,0</sub> = 52 mm

B [mm]	H [mm]	full nailing						partial nailing					
		n <sub>H</sub>	n <sub>J</sub>	k <sub>H,1</sub>	k <sub>H,2</sub>	e <sub>1</sub> [mm]	e <sub>2</sub> [mm]	n <sub>H</sub>	n <sub>J</sub>	k <sub>H,1</sub>	k <sub>H,2</sub>	e <sub>1</sub> [mm]	e <sub>2</sub> [mm]
51	325	52	28	124	85,0	3320	7218	26	14	61,2	41,7	1518	4858
60	320	52	28	121	85,0	3506	7069	26	14	59,5	41,7	1596	4559
62	319	52	28	120	85,0	3550	7044	26	14	59,1	41,7	1614	4504
64	318	52	28	119	85,0	3595	7021	26	14	58,7	41,7	1633	4453
66	317	52	28	119	85,0	3640	7000	26	14	58,3	41,7	1652	4406
68	316	52	28	118	85,0	3686	6981	26	14	58,0	41,7	1672	4361
70	315	52	28	117	85,0	3733	6965	26	14	57,6	41,7	1692	4320
72	314	52	28	116	85,0	3781	6950	26	14	57,2	41,7	1713	4281
73	314	52	28	116	85,0	3805	6944	26	14	57,0	41,7	1723	4263
74	313	52	28	116	85,0	3830	6938	26	14	56,8	41,7	1734	4245
76	312	52	28	115	85,0	3879	6927	26	14	56,5	41,7	1755	4212
78	311	52	28	114	85,0	3930	6918	26	14	56,1	41,7	1777	4181
80	310	52	28	113	85,0	3981	6911	26	14	55,7	41,7	1799	4152
82	309	52	28	113	85,0	4033	6905	26	14	55,3	41,7	1822	4125
84	308	52	28	112	85,0	4086	6901	26	14	55,0	41,7	1845	4100
86	307	52	28	111	85,0	4139	6899	26	14	54,6	41,7	1869	4077
88	306	52	28	110	85,0	4194	6898	26	14	54,2	41,7	1893	4056
90	305	52	28	110	85,0	4249	6898	26	14	53,9	41,7	1917	4036
92	304	52	28	109	85,0	4305	6899	26	14	53,5	41,7	1942	4018
94	303	52	28	108	85,0	4362	6902	26	14	53,1	41,7	1968	4002
96	302	52	28	107	85,0	4420	6906	26	14	52,8	41,7	1993	3987
98	301	52	28	107	85,0	4479	6912	26	14	52,4	41,7	2020	3973
100	300	52	28	106	85,0	4538	6918	26	14	52,0	41,7	2046	3960

Table B8: Joist hanger Blank 740 (100 x 320): Form factors k<sub>H,1</sub> and k<sub>H,2</sub> and dimensions e<sub>1</sub> and e<sub>2</sub>; e<sub>J,0</sub> = 52 mm

B [mm]	H [mm]	full nailing						partial nailing					
		n <sub>H</sub>	n <sub>J</sub>	k <sub>H,1</sub>	k <sub>H,2</sub>	e <sub>1</sub> [mm]	e <sub>2</sub> [mm]	n <sub>H</sub>	n <sub>J</sub>	k <sub>H,1</sub>	k <sub>H,2</sub>	e <sub>1</sub> [mm]	e <sub>2</sub> [mm]
51	345	56	30	141	98,7	3684	8650	28	15	69,4	48,5	1703	5903
60	340	56	30	137	98,7	3870	8426	28	15	67,6	48,5	1780	5509
62	339	56	30	136	98,7	3913	8386	28	15	67,2	48,5	1798	5437

B [mm]	H [mm]	full nailing						partial nailing					
		n <sub>H</sub>	n <sub>J</sub>	k <sub>H,1</sub>	k <sub>H,2</sub>	e <sub>1</sub> [mm]	e <sub>2</sub> [mm]	n <sub>H</sub>	n <sub>J</sub>	k <sub>H,1</sub>	k <sub>H,2</sub>	e <sub>1</sub> [mm]	e <sub>2</sub> [mm]
64	338	56	30	136	98,7	3958	8348	28	15	66,8	48,5	1817	5368
66	337	56	30	135	98,7	4003	8314	28	15	66,4	48,5	1836	5304
68	336	56	30	134	98,7	4049	8282	28	15	65,9	48,5	1856	5245
70	335	56	30	133	98,7	4096	8253	28	15	65,5	48,5	1876	5188
72	334	56	30	132	98,7	4144	8226	28	15	65,1	48,5	1896	5136
73	334	56	30	132	98,7	4168	8214	28	15	64,9	48,5	1907	5111
74	333	56	30	132	98,7	4192	8202	28	15	64,7	48,5	1917	5086
76	332	56	30	131	98,7	4241	8180	28	15	64,3	48,5	1938	5040
78	331	56	30	130	98,7	4292	8160	28	15	63,9	48,5	1960	4997
80	330	56	30	129	98,7	4343	8143	28	15	63,5	48,5	1982	4956
82	329	56	30	128	98,7	4395	8127	28	15	63,1	48,5	2005	4918
84	328	56	30	128	98,7	4447	8113	28	15	62,7	48,5	2028	4882
86	327	56	30	127	98,7	4501	8101	28	15	62,3	48,5	2052	4849
88	326	56	30	126	98,7	4555	8091	28	15	62,0	48,5	2075	4818
90	325	56	30	125	98,7	4610	8083	28	15	61,6	48,5	2100	4789
92	324	56	30	124	98,7	4666	8076	28	15	61,2	48,5	2125	4762
94	323	56	30	124	98,7	4723	8071	28	15	60,8	48,5	2150	4737
96	322	56	30	123	98,7	4781	8068	28	15	60,4	48,5	2175	4713
98	321	56	30	122	98,7	4839	8065	28	15	60,0	48,5	2201	4692
100	320	56	30	121	98,7	4899	8065	28	15	59,6	48,5	2228	4671

Table B9: Joist hanger Blank 480 (120 x 180): Form factors k<sub>H,1</sub> and k<sub>H,2</sub> and dimensions e<sub>1</sub> and e<sub>2</sub>; e<sub>J,0</sub> = 52 mm

B [mm]	H [mm]	full nailing						partial nailing					
		n <sub>H</sub>	n <sub>J</sub>	k <sub>H,1</sub>	k <sub>H,2</sub>	e <sub>1</sub> [mm]	e <sub>2</sub> [mm]	n <sub>H</sub>	n <sub>J</sub>	k <sub>H,1</sub>	k <sub>H,2</sub>	e <sub>1</sub> [mm]	e <sub>2</sub> [mm]
51	215	28	16	50,9	24,2	1715	1939	14	8	25,0	11,7	701	1122
60	210	28	16	48,9	24,2	1908	2000	14	8	23,9	11,7	785	1121
62	209	28	16	48,4	24,2	1953	2015	14	8	23,7	11,7	805	1123
64	208	28	16	48,0	24,2	1999	2030	14	8	23,5	11,7	825	1125
66	207	28	16	47,5	24,2	2046	2046	14	8	23,3	11,7	846	1128
68	206	28	16	47,1	24,2	2094	2062	14	8	23,0	11,7	867	1131
70	205	28	16	46,6	24,2	2143	2079	14	8	22,8	11,7	889	1135
72	204	28	16	46,2	24,2	2192	2095	14	8	22,6	11,7	911	1139
73	204	28	16	46,0	24,2	2217	2104	14	8	22,5	11,7	922	1141
74	203	28	16	45,8	24,2	2243	2113	14	8	22,4	11,7	934	1143
76	202	28	16	45,3	24,2	2294	2130	14	8	22,1	11,7	957	1148
78	201	28	16	44,9	24,2	2346	2148	14	8	21,9	11,7	980	1153
80	200	28	16	44,4	24,2	2399	2166	14	8	21,7	11,7	1004	1159
82	199	28	16	44,0	24,2	2453	2184	14	8	21,5	11,7	1029	1165
84	198	28	16	43,5	24,2	2508	2203	14	8	21,3	11,7	1054	1171
86	197	28	16	43,1	24,2	2563	2221	14	8	21,0	11,7	1079	1177
88	196	28	16	42,7	24,2	2620	2240	14	8	20,8	11,7	1105	1184
90	195	28	16	42,2	24,2	2677	2260	14	8	20,6	11,7	1131	1191
92	194	28	16	41,8	24,2	2735	2279	14	8	20,4	11,7	1158	1198
94	193	28	16	41,4	24,2	2794	2299	14	8	20,2	11,7	1186	1206
96	192	28	16	40,9	24,2	2854	2319	14	8	19,9	11,7	1213	1213
98	191	28	16	40,5	24,2	2915	2339	14	8	19,7	11,7	1242	1221
100	190	28	16	40,1	24,2	2976	2359	14	8	19,5	11,7	1270	1229
102	189	28	16	39,6	24,2	3039	2380	14	8	19,3	11,7	1299	1238
104	188	28	16	39,2	24,2	3102	2400	14	8	19,1	11,7	1329	1246
106	187	28	16	38,8	24,2	3166	2421	14	8	18,9	11,7	1359	1255
108	186	28	16	38,4	24,2	3231	2442	14	8	18,7	11,7	1390	1263



B [mm]	H [mm]	full nailing						partial nailing					
		n <sub>H</sub>	n <sub>J</sub>	k <sub>H,1</sub>	k <sub>H,2</sub>	e <sub>1</sub> [mm]	e <sub>2</sub> [mm]	n <sub>H</sub>	n <sub>J</sub>	k <sub>H,1</sub>	k <sub>H,2</sub>	e <sub>1</sub> [mm]	e <sub>2</sub> [mm]
110	185	28	16	37,9	24,2	3297	2463	14	8	18,5	11,7	1421	1272
112	184	28	16	37,5	24,2	3364	2485	14	8	18,2	11,7	1452	1281
114	183	28	16	37,1	24,2	3432	2506	14	8	18,0	11,7	1484	1291
116	182	28	16	36,7	24,2	3500	2528	14	8	17,8	11,7	1517	1300
118	181	28	16	36,3	24,2	3569	2550	14	8	17,6	11,7	1550	1309
120	180	28	16	35,8	24,2	3640	2571	14	8	17,4	11,7	1583	1319

Table B10: Joist hanger Blank 520 (120 x 200): Form factors k<sub>H,1</sub> and k<sub>H,2</sub> and dimensions e<sub>1</sub> and e<sub>2</sub>; e<sub>J,0</sub> = 52 mm

B [mm]	H [mm]	full nailing						partial nailing					
		n <sub>H</sub>	n <sub>J</sub>	k <sub>H,1</sub>	k <sub>H,2</sub>	e <sub>1</sub> [mm]	e <sub>2</sub> [mm]	n <sub>H</sub>	n <sub>J</sub>	k <sub>H,1</sub>	k <sub>H,2</sub>	e <sub>1</sub> [mm]	e <sub>2</sub> [mm]
51	235	32	18	61,9	31,8	1912	2494	16	9	30,4	15,4	801	1496
60	230	32	18	59,6	31,8	2103	2544	16	9	29,2	15,4	883	1472
62	229	32	18	59,1	31,8	2148	2557	16	9	29,0	15,4	903	1469
64	228	32	18	58,6	31,8	2193	2571	16	9	28,7	15,4	923	1468
66	227	32	18	58,1	31,8	2240	2585	16	9	28,5	15,4	943	1467
68	226	32	18	57,6	31,8	2287	2599	16	9	28,2	15,4	964	1466
70	225	32	18	57,1	31,8	2336	2614	16	9	28,0	15,4	985	1467
72	224	32	18	56,6	31,8	2385	2630	16	9	27,7	15,4	1007	1468
73	224	32	18	56,4	31,8	2409	2638	16	9	27,6	15,4	1018	1469
74	223	32	18	56,1	31,8	2435	2646	16	9	27,5	15,4	1029	1470
76	222	32	18	55,6	31,8	2485	2663	16	9	27,2	15,4	1051	1472
78	221	32	18	55,1	31,8	2537	2680	16	9	27,0	15,4	1075	1475
80	220	32	18	54,6	31,8	2589	2697	16	9	26,7	15,4	1098	1478
82	219	32	18	54,1	31,8	2643	2715	16	9	26,5	15,4	1122	1482
84	218	32	18	53,6	31,8	2697	2733	16	9	26,2	15,4	1147	1486
86	217	32	18	53,1	31,8	2752	2752	16	9	26,0	15,4	1171	1491
88	216	32	18	52,6	31,8	2808	2771	16	9	25,7	15,4	1197	1496
90	215	32	18	52,1	31,8	2865	2790	16	9	25,5	15,4	1223	1501
92	214	32	18	51,7	31,8	2922	2810	16	9	25,2	15,4	1249	1507
94	213	32	18	51,2	31,8	2981	2830	16	9	25,0	15,4	1276	1513
96	212	32	18	50,7	31,8	3040	2850	16	9	24,8	15,4	1303	1520
98	211	32	18	50,2	31,8	3100	2871	16	9	24,5	15,4	1331	1527
100	210	32	18	49,7	31,8	3161	2891	16	9	24,3	15,4	1359	1534
102	209	32	18	49,2	31,8	3223	2912	16	9	24,0	15,4	1387	1541
104	208	32	18	48,8	31,8	3286	2934	16	9	23,8	15,4	1416	1549
106	207	32	18	48,3	31,8	3349	2955	16	9	23,6	15,4	1446	1557
108	206	32	18	47,8	31,8	3414	2977	16	9	23,3	15,4	1476	1565
110	205	32	18	47,3	31,8	3479	2999	16	9	23,1	15,4	1506	1573
112	204	32	18	46,8	31,8	3545	3021	16	9	22,8	15,4	1537	1582
114	203	32	18	46,4	31,8	3612	3044	16	9	22,6	15,4	1568	1591
116	202	32	18	45,9	31,8	3680	3067	16	9	22,4	15,4	1600	1600
118	201	32	18	45,4	31,8	3749	3090	16	9	22,1	15,4	1632	1609
120	200	32	18	45,0	31,8	3818	3113	16	9	21,9	15,4	1665	1619

Table B11: Joist hanger Blank 560 (120 x 220): Form factors k<sub>H,1</sub> and k<sub>H,2</sub> and dimensions e<sub>1</sub> and e<sub>2</sub>; e<sub>J,0</sub> = 52 mm

B [mm]	H [mm]	full nailing						partial nailing					
		n <sub>H</sub>	n <sub>J</sub>	k <sub>H,1</sub>	k <sub>H,2</sub>	e <sub>1</sub> [mm]	e <sub>2</sub> [mm]	n <sub>H</sub>	n <sub>J</sub>	k <sub>H,1</sub>	k <sub>H,2</sub>	e <sub>1</sub> [mm]	e <sub>2</sub> [mm]
51	255	36	20	73,9	40,4	2138	3160	18	10	36,3	19,6	916	1955
60	250	36	20	71,4	40,4	2328	3191	18	10	35,0	19,6	997	1899
62	249	36	20	70,8	40,4	2372	3200	18	10	34,8	19,6	1016	1890

B [mm]	H [mm]	full nailing						partial nailing					
		n <sub>H</sub>	n <sub>J</sub>	k <sub>H,1</sub>	k <sub>H,2</sub>	e <sub>1</sub> [mm]	e <sub>2</sub> [mm]	n <sub>H</sub>	n <sub>J</sub>	k <sub>H,1</sub>	k <sub>H,2</sub>	e <sub>1</sub> [mm]	e <sub>2</sub> [mm]
64	248	36	20	70,3	40,4	2417	3211	18	10	34,5	19,6	1036	1883
66	247	36	20	69,7	40,4	2464	3222	18	10	34,2	19,6	1056	1877
68	246	36	20	69,1	40,4	2511	3233	18	10	33,9	19,6	1076	1871
70	245	36	20	68,6	40,4	2558	3246	18	10	33,6	19,6	1097	1867
72	244	36	20	68,0	40,4	2607	3259	18	10	33,4	19,6	1118	1864
73	244	36	20	67,8	40,4	2632	3266	18	10	33,2	19,6	1129	1863
74	243	36	20	67,5	40,4	2657	3273	18	10	33,1	19,6	1140	1862
76	242	36	20	66,9	40,4	2707	3287	18	10	32,8	19,6	1163	1860
78	241	36	20	66,4	40,4	2758	3302	18	10	32,5	19,6	1185	1859
80	240	36	20	65,8	40,4	2810	3318	18	10	32,3	19,6	1208	1859
82	239	36	20	65,3	40,4	2863	3334	18	10	32,0	19,6	1232	1860
84	238	36	20	64,7	40,4	2917	3351	18	10	31,7	19,6	1256	1861
86	237	36	20	64,2	40,4	2972	3368	18	10	31,4	19,6	1281	1863
88	236	36	20	63,6	40,4	3027	3386	18	10	31,2	19,6	1306	1865
90	235	36	20	63,1	40,4	3084	3404	18	10	30,9	19,6	1331	1868
92	234	36	20	62,5	40,4	3141	3423	18	10	30,6	19,6	1357	1872
94	233	36	20	62,0	40,4	3199	3442	18	10	30,3	19,6	1383	1876
96	232	36	20	61,5	40,4	3258	3461	18	10	30,1	19,6	1410	1880
98	231	36	20	60,9	40,4	3317	3481	18	10	29,8	19,6	1437	1885
100	230	36	20	60,4	40,4	3378	3502	18	10	29,5	19,6	1465	1890
102	229	36	20	59,8	40,4	3439	3522	18	10	29,3	19,6	1493	1896
104	228	36	20	59,3	40,4	3502	3543	18	10	29,0	19,6	1522	1902
106	227	36	20	58,8	40,4	3565	3565	18	10	28,7	19,6	1551	1908
108	226	36	20	58,3	40,4	3629	3586	18	10	28,5	19,6	1580	1915
110	225	36	20	57,7	40,4	3693	3609	18	10	28,2	19,6	1610	1922
112	224	36	20	57,2	40,4	3759	3631	18	10	27,9	19,6	1640	1930
114	223	36	20	56,7	40,4	3826	3654	18	10	27,7	19,6	1671	1938
116	222	36	20	56,1	40,4	3893	3677	18	10	27,4	19,6	1703	1946
118	221	36	20	55,6	40,4	3961	3700	18	10	27,2	19,6	1734	1954
120	220	36	20	55,1	40,4	4030	3724	18	10	26,9	19,6	1766	1963

Table B12: Joist hanger Blank 600 (120 x 240): Form factors k<sub>H,1</sub> and k<sub>H,2</sub> and dimensions e<sub>1</sub> and e<sub>2</sub>; e<sub>J,0</sub> = 52 mm

B [mm]	H [mm]	full nailing						partial nailing					
		n <sub>H</sub>	n <sub>J</sub>	k <sub>H,1</sub>	k <sub>H,2</sub>	e <sub>1</sub> [mm]	e <sub>2</sub> [mm]	n <sub>H</sub>	n <sub>J</sub>	k <sub>H,1</sub>	k <sub>H,2</sub>	e <sub>1</sub> [mm]	e <sub>2</sub> [mm]
51	275	40	22	86,9	50,0	2392	3952	20	11	42,7	24,4	1046	2510
60	270	40	22	84,2	50,0	2581	3954	20	11	41,3	24,4	1125	2411
62	269	40	22	83,5	50,0	2625	3958	20	11	41,0	24,4	1144	2395
64	268	40	22	82,9	50,0	2670	3963	20	11	40,7	24,4	1164	2380
66	267	40	22	82,3	50,0	2716	3969	20	11	40,4	24,4	1183	2367
68	266	40	22	81,7	50,0	2763	3976	20	11	40,1	24,4	1204	2355
70	265	40	22	81,1	50,0	2810	3984	20	11	39,8	24,4	1224	2344
72	264	40	22	80,5	50,0	2859	3994	20	11	39,5	24,4	1245	2335
73	264	40	22	80,2	50,0	2883	3998	20	11	39,4	24,4	1256	2331
74	263	40	22	79,9	50,0	2908	4003	20	11	39,2	24,4	1267	2327
76	262	40	22	79,3	50,0	2958	4014	20	11	38,9	24,4	1289	2320
78	261	40	22	78,6	50,0	3009	4026	20	11	38,6	24,4	1311	2314
80	260	40	22	78,0	50,0	3061	4038	20	11	38,3	24,4	1334	2309
82	259	40	22	77,4	50,0	3113	4052	20	11	38,0	24,4	1358	2305
84	258	40	22	76,8	50,0	3167	4065	20	11	37,7	24,4	1381	2302
86	257	40	22	76,2	50,0	3221	4080	20	11	37,4	24,4	1406	2300
88	256	40	22	75,6	50,0	3276	4095	20	11	37,1	24,4	1430	2299

B [mm]	H [mm]	full nailing						partial nailing					
		n <sub>H</sub>	n <sub>J</sub>	k <sub>H,1</sub>	k <sub>H,2</sub>	e <sub>1</sub> [mm]	e <sub>2</sub> [mm]	n <sub>H</sub>	n <sub>J</sub>	k <sub>H,1</sub>	k <sub>H,2</sub>	e <sub>1</sub> [mm]	e <sub>2</sub> [mm]
90	255	40	22	75,0	50,0	3332	4111	20	11	36,8	24,4	1455	2298
92	254	40	22	74,4	50,0	3389	4128	20	11	36,5	24,4	1481	2298
94	253	40	22	73,8	50,0	3447	4145	20	11	36,2	24,4	1507	2299
96	252	40	22	73,3	50,0	3505	4163	20	11	35,9	24,4	1533	2300
98	251	40	22	72,7	50,0	3565	4181	20	11	35,6	24,4	1560	2302
100	250	40	22	72,1	50,0	3625	4200	20	11	35,3	24,4	1588	2305
102	249	40	22	71,5	50,0	3686	4219	20	11	35,0	24,4	1615	2308
104	248	40	22	70,9	50,0	3748	4239	20	11	34,7	24,4	1644	2311
106	247	40	22	70,3	50,0	3811	4259	20	11	34,4	24,4	1672	2315
108	246	40	22	69,7	50,0	3874	4280	20	11	34,1	24,4	1701	2320
110	245	40	22	69,1	50,0	3939	4301	20	11	33,9	24,4	1731	2325
112	244	40	22	68,6	50,0	4004	4322	20	11	33,6	24,4	1761	2331
114	243	40	22	68,0	50,0	4070	4344	20	11	33,3	24,4	1791	2337
116	242	40	22	67,4	50,0	4137	4367	20	11	33,0	24,4	1822	2343
118	241	40	22	66,8	50,0	4205	4389	20	11	32,7	24,4	1854	2350
120	240	40	22	66,3	50,0	4273	4413	20	11	32,4	24,4	1885	2357

Table B13: Joist hanger Blank 640 (120 x 260): Form factors k<sub>H,1</sub> and k<sub>H,2</sub> and dimensions e<sub>1</sub> and e<sub>2</sub>; e<sub>J,0</sub> = 52 mm

B [mm]	H [mm]	full nailing						partial nailing					
		n <sub>H</sub>	n <sub>J</sub>	k <sub>H,1</sub>	k <sub>H,2</sub>	e <sub>1</sub> [mm]	e <sub>2</sub> [mm]	n <sub>H</sub>	n <sub>J</sub>	k <sub>H,1</sub>	k <sub>H,2</sub>	e <sub>1</sub> [mm]	e <sub>2</sub> [mm]
51	295	44	24	101	60,6	2674	4883	22	12	49,7	29,6	1189	3172
60	290	44	24	97,9	60,6	2862	4846	22	12	48,2	29,6	1268	3019
62	289	44	24	97,3	60,6	2906	4843	22	12	47,8	29,6	1287	2993
64	288	44	24	96,6	60,6	2951	4841	22	12	47,5	29,6	1306	2968
66	287	44	24	95,9	60,6	2996	4840	22	12	47,2	29,6	1326	2946
68	286	44	24	95,3	60,6	3043	4841	22	12	46,8	29,6	1346	2925
70	285	44	24	94,6	60,6	3090	4843	22	12	46,5	29,6	1366	2906
72	284	44	24	93,9	60,6	3138	4846	22	12	46,2	29,6	1387	2889
73	284	44	24	93,6	60,6	3163	4848	22	12	46,0	29,6	1397	2881
74	283	44	24	93,3	60,6	3187	4850	22	12	45,8	29,6	1408	2874
76	282	44	24	92,6	60,6	3237	4856	22	12	45,5	29,6	1430	2860
78	281	44	24	91,9	60,6	3288	4862	22	12	45,2	29,6	1452	2847
80	280	44	24	91,3	60,6	3339	4870	22	12	44,8	29,6	1475	2836
82	279	44	24	90,6	60,6	3392	4879	22	12	44,5	29,6	1498	2826
84	278	44	24	90,0	60,6	3445	4888	22	12	44,2	29,6	1522	2818
86	277	44	24	89,3	60,6	3499	4899	22	12	43,9	29,6	1546	2810
88	276	44	24	88,7	60,6	3554	4910	22	12	43,5	29,6	1570	2803
90	275	44	24	88,0	60,6	3610	4922	22	12	43,2	29,6	1595	2798
92	274	44	24	87,4	60,6	3666	4935	22	12	42,9	29,6	1620	2793
94	273	44	24	86,7	60,6	3724	4949	22	12	42,6	29,6	1646	2790
96	272	44	24	86,1	60,6	3782	4964	22	12	42,2	29,6	1672	2787
98	271	44	24	85,4	60,6	3841	4979	22	12	41,9	29,6	1699	2785
100	270	44	24	84,8	60,6	3901	4995	22	12	41,6	29,6	1726	2783
102	269	44	24	84,1	60,6	3962	5012	22	12	41,3	29,6	1753	2783
104	268	44	24	83,5	60,6	4023	5029	22	12	41,0	29,6	1781	2783
106	267	44	24	82,9	60,6	4086	5047	22	12	40,6	29,6	1810	2784
108	266	44	24	82,2	60,6	4149	5066	22	12	40,3	29,6	1838	2785
110	265	44	24	81,6	60,6	4213	5085	22	12	40,0	29,6	1868	2787
112	264	44	24	81,0	60,6	4278	5105	22	12	39,7	29,6	1897	2790
114	263	44	24	80,3	60,6	4344	5125	22	12	39,4	29,6	1927	2793
116	262	44	24	79,7	60,6	4410	5146	22	12	39,1	29,6	1958	2797

B [mm]	H [mm]	full nailing						partial nailing					
		n <sub>H</sub>	n <sub>J</sub>	k <sub>H,1</sub>	k <sub>H,2</sub>	e <sub>1</sub> [mm]	e <sub>2</sub> [mm]	n <sub>H</sub>	n <sub>J</sub>	k <sub>H,1</sub>	k <sub>H,2</sub>	e <sub>1</sub> [mm]	e <sub>2</sub> [mm]
118	261	44	24	79,1	60,6	4478	5167	22	12	38,8	29,6	1989	2801
120	260	44	24	78,4	60,6	4546	5189	22	12	38,4	29,6	2020	2806

Table B14: Joist hanger Blank 680 (120 x 280): Form factors k<sub>H,1</sub> and k<sub>H,2</sub> and dimensions e<sub>1</sub> and e<sub>2</sub>; e<sub>J,0</sub> = 52 mm

B [mm]	H [mm]	full nailing						partial nailing					
		n <sub>H</sub>	n <sub>J</sub>	k <sub>H,1</sub>	k <sub>H,2</sub>	e <sub>1</sub> [mm]	e <sub>2</sub> [mm]	n <sub>H</sub>	n <sub>J</sub>	k <sub>H,1</sub>	k <sub>H,2</sub>	e <sub>1</sub> [mm]	e <sub>2</sub> [mm]
51	315	48	26	116	72,3	2983	5967	24	13	57,1	35,4	1347	3951
60	310	48	26	113	72,3	3170	5881	24	13	55,5	35,4	1425	3732
62	309	48	26	112	72,3	3214	5867	24	13	55,1	35,4	1443	3692
64	308	48	26	111	72,3	3259	5856	24	13	54,8	35,4	1462	3656
66	307	48	26	111	72,3	3304	5846	24	13	54,4	35,4	1482	3622
68	306	48	26	110	72,3	3351	5838	24	13	54,1	35,4	1502	3591
70	305	48	26	109	72,3	3398	5832	24	13	53,7	35,4	1522	3562
72	304	48	26	108	72,3	3446	5828	24	13	53,3	35,4	1543	3535
73	304	48	26	108	72,3	3470	5826	24	13	53,2	35,4	1553	3523
74	303	48	26	108	72,3	3495	5824	24	13	53,0	35,4	1564	3511
76	302	48	26	107	72,3	3544	5823	24	13	52,6	35,4	1585	3488
78	301	48	26	106	72,3	3595	5823	24	13	52,3	35,4	1607	3467
80	300	48	26	106	72,3	3646	5824	24	13	51,9	35,4	1630	3448
82	299	48	26	105	72,3	3698	5826	24	13	51,6	35,4	1653	3430
84	298	48	26	104	72,3	3751	5830	24	13	51,2	35,4	1676	3415
86	297	48	26	103	72,3	3805	5835	24	13	50,8	35,4	1700	3400
88	296	48	26	103	72,3	3860	5841	24	13	50,5	35,4	1724	3387
90	295	48	26	102	72,3	3915	5848	24	13	50,1	35,4	1749	3375
92	294	48	26	101	72,3	3972	5856	24	13	49,8	35,4	1774	3364
94	293	48	26	101	72,3	4029	5865	24	13	49,4	35,4	1799	3355
96	292	48	26	99,9	72,3	4087	5875	24	13	49,1	35,4	1825	3347
98	291	48	26	99,2	72,3	4146	5886	24	13	48,7	35,4	1852	3339
100	290	48	26	98,5	72,3	4205	5898	24	13	48,4	35,4	1879	3333
102	289	48	26	97,8	72,3	4266	5911	24	13	48,1	35,4	1906	3328
104	288	48	26	97,1	72,3	4327	5924	24	13	47,7	35,4	1934	3324
106	287	48	26	96,4	72,3	4390	5939	24	13	47,4	35,4	1962	3320
108	286	48	26	95,8	72,3	4453	5954	24	13	47,0	35,4	1990	3317
110	285	48	26	95,1	72,3	4516	5970	24	13	46,7	35,4	2019	3315
112	284	48	26	94,4	72,3	4581	5987	24	13	46,3	35,4	2049	3314
114	283	48	26	93,7	72,3	4647	6004	24	13	46,0	35,4	2079	3314
116	282	48	26	93,0	72,3	4713	6022	24	13	45,7	35,4	2109	3314
118	281	48	26	92,3	72,3	4780	6041	24	13	45,3	35,4	2140	3315
120	280	48	26	91,7	72,3	4848	6060	24	13	45,0	35,4	2171	3317

Table B15: Joist hanger Blank 720 (120 x 300): Form factors k<sub>H,1</sub> and k<sub>H,2</sub> and dimensions e<sub>1</sub> and e<sub>2</sub>; e<sub>J,0</sub> = 52 mm

B [mm]	H [mm]	full nailing						partial nailing					
		n <sub>H</sub>	n <sub>J</sub>	k <sub>H,1</sub>	k <sub>H,2</sub>	e <sub>1</sub> [mm]	e <sub>2</sub> [mm]	n <sub>H</sub>	n <sub>J</sub>	k <sub>H,1</sub>	k <sub>H,2</sub>	e <sub>1</sub> [mm]	e <sub>2</sub> [mm]
51	335	52	28	132	85,0	3320	7218	26	14	65,1	41,7	1518	4858
60	330	52	28	129	85,0	3506	7069	26	14	63,3	41,7	1596	4559
62	329	52	28	128	85,0	3550	7044	26	14	62,9	41,7	1614	4504
64	328	52	28	127	85,0	3595	7021	26	14	62,6	41,7	1633	4453
66	327	52	28	126	85,0	3640	7000	26	14	62,2	41,7	1652	4406
68	326	52	28	125	85,0	3686	6981	26	14	61,8	41,7	1672	4361
70	325	52	28	125	85,0	3733	6965	26	14	61,4	41,7	1692	4320

B [mm]	H [mm]	full nailing						partial nailing					
		n <sub>H</sub>	n <sub>J</sub>	k <sub>H,1</sub>	k <sub>H,2</sub>	e <sub>1</sub> [mm]	e <sub>2</sub> [mm]	n <sub>H</sub>	n <sub>J</sub>	k <sub>H,1</sub>	k <sub>H,2</sub>	e <sub>1</sub> [mm]	e <sub>2</sub> [mm]
72	324	52	28	124	85,0	3781	6950	26	14	61,0	41,7	1713	4281
73	324	52	28	124	85,0	3805	6944	26	14	60,8	41,7	1723	4263
74	323	52	28	123	85,0	3830	6938	26	14	60,6	41,7	1734	4245
76	322	52	28	122	85,0	3879	6927	26	14	60,2	41,7	1755	4212
78	321	52	28	122	85,0	3930	6918	26	14	59,9	41,7	1777	4181
80	320	52	28	121	85,0	3981	6911	26	14	59,5	41,7	1799	4152
82	319	52	28	120	85,0	4033	6905	26	14	59,1	41,7	1822	4125
84	318	52	28	119	85,0	4086	6901	26	14	58,7	41,7	1845	4100
86	317	52	28	119	85,0	4139	6899	26	14	58,3	41,7	1869	4077
88	316	52	28	118	85,0	4194	6898	26	14	58,0	41,7	1893	4056
90	315	52	28	117	85,0	4249	6898	26	14	57,6	41,7	1917	4036
92	314	52	28	116	85,0	4305	6899	26	14	57,2	41,7	1942	4018
94	313	52	28	116	85,0	4362	6902	26	14	56,8	41,7	1968	4002
96	312	52	28	115	85,0	4420	6906	26	14	56,5	41,7	1993	3987
98	311	52	28	114	85,0	4479	6912	26	14	56,1	41,7	2020	3973
100	310	52	28	113	85,0	4538	6918	26	14	55,7	41,7	2046	3960
102	309	52	28	113	85,0	4598	6925	26	14	55,3	41,7	2073	3949
104	308	52	28	112	85,0	4660	6934	26	14	55,0	41,7	2101	3939
106	307	52	28	111	85,0	4722	6944	26	14	54,6	41,7	2129	3930
108	306	52	28	110	85,0	4784	6954	26	14	54,2	41,7	2157	3922
110	305	52	28	110	85,0	4848	6966	26	14	53,9	41,7	2186	3915
112	304	52	28	109	85,0	4913	6978	26	14	53,5	41,7	2215	3909
114	303	52	28	108	85,0	4978	6991	26	14	53,1	41,7	2245	3904
116	302	52	28	107	85,0	5044	7006	26	14	52,8	41,7	2275	3900
118	301	52	28	107	85,0	5111	7021	26	14	52,4	41,7	2306	3897
120	300	52	28	106	85,0	5179	7036	26	14	52,0	41,7	2337	3894

Table B16: Joist hanger Blank 760 (120 x 320): Form factors k<sub>H,1</sub> and k<sub>H,2</sub> and dimensions e<sub>1</sub> and e<sub>2</sub>; e<sub>1,0</sub> = 52 mm

B [mm]	H [mm]	full nailing						partial nailing					
		n <sub>H</sub>	n <sub>J</sub>	k <sub>H,1</sub>	k <sub>H,2</sub>	e <sub>1</sub> [mm]	e <sub>2</sub> [mm]	n <sub>H</sub>	n <sub>J</sub>	k <sub>H,1</sub>	k <sub>H,2</sub>	e <sub>1</sub> [mm]	e <sub>2</sub> [mm]
51	355	56	30	149	98,7	3684	8650	28	15	73,6	48,5	1703	5903
60	350	56	30	145	98,7	3870	8426	28	15	71,7	48,5	1780	5509
62	349	56	30	145	98,7	3913	8386	28	15	71,3	48,5	1798	5437
64	348	56	30	144	98,7	3958	8348	28	15	70,9	48,5	1817	5368
66	347	56	30	143	98,7	4003	8314	28	15	70,4	48,5	1836	5304
68	346	56	30	142	98,7	4049	8282	28	15	70,0	48,5	1856	5245
70	345	56	30	141	98,7	4096	8253	28	15	69,6	48,5	1876	5188
72	344	56	30	140	98,7	4144	8226	28	15	69,2	48,5	1896	5136
73	344	56	30	140	98,7	4168	8214	28	15	69,0	48,5	1907	5111
74	343	56	30	140	98,7	4192	8202	28	15	68,8	48,5	1917	5086
76	342	56	30	139	98,7	4241	8180	28	15	68,4	48,5	1938	5040
78	341	56	30	138	98,7	4292	8160	28	15	68,0	48,5	1960	4997
80	340	56	30	137	98,7	4343	8143	28	15	67,6	48,5	1982	4956
82	339	56	30	136	98,7	4395	8127	28	15	67,2	48,5	2005	4918
84	338	56	30	136	98,7	4447	8113	28	15	66,8	48,5	2028	4882
86	337	56	30	135	98,7	4501	8101	28	15	66,4	48,5	2052	4849
88	336	56	30	134	98,7	4555	8091	28	15	65,9	48,5	2075	4818
90	335	56	30	133	98,7	4610	8083	28	15	65,5	48,5	2100	4789
92	334	56	30	132	98,7	4666	8076	28	15	65,1	48,5	2125	4762
94	333	56	30	131	98,7	4723	8071	28	15	64,7	48,5	2150	4737
96	332	56	30	131	98,7	4781	8068	28	15	64,3	48,5	2175	4713

B [mm]	H [mm]	full nailing						partial nailing					
		n <sub>H</sub>	n <sub>J</sub>	k <sub>H,1</sub>	k <sub>H,2</sub>	e <sub>1</sub> [mm]	e <sub>2</sub> [mm]	n <sub>H</sub>	n <sub>J</sub>	k <sub>H,1</sub>	k <sub>H,2</sub>	e <sub>1</sub> [mm]	e <sub>2</sub> [mm]
98	331	56	30	130	98,7	4839	8065	28	15	63,9	48,5	2201	4692
100	330	56	30	129	98,7	4899	8065	28	15	63,5	48,5	2228	4671
102	329	56	30	128	98,7	4959	8065	28	15	63,1	48,5	2255	4653
104	328	56	30	127	98,7	5020	8067	28	15	62,7	48,5	2282	4636
106	327	56	30	127	98,7	5081	8071	28	15	62,3	48,5	2310	4620
108	326	56	30	126	98,7	5144	8075	28	15	62,0	48,5	2338	4606
110	325	56	30	125	98,7	5208	8081	28	15	61,6	48,5	2367	4592
112	324	56	30	124	98,7	5272	8088	28	15	61,2	48,5	2396	4580
114	323	56	30	124	98,7	5337	8095	28	15	60,8	48,5	2425	4570
116	322	56	30	123	98,7	5403	8104	28	15	60,4	48,5	2455	4560
118	321	56	30	122	98,7	5470	8114	28	15	60,0	48,5	2486	4551
120	320	56	30	121	98,7	5537	8125	28	15	59,6	48,5	2517	4544

Table B17: Joist hanger Blank 500 (140 x 180): Form factors k<sub>H,1</sub> and k<sub>H,2</sub> and dimensions e<sub>1</sub> and e<sub>2</sub>; e<sub>1,0</sub> = 52 mm

B [mm]	H [mm]	full nailing						partial nailing					
		n <sub>H</sub>	n <sub>J</sub>	k <sub>H,1</sub>	k <sub>H,2</sub>	e <sub>1</sub> [mm]	e <sub>2</sub> [mm]	n <sub>H</sub>	n <sub>J</sub>	k <sub>H,1</sub>	k <sub>H,2</sub>	e <sub>1</sub> [mm]	e <sub>2</sub> [mm]
51	225	28	16	55,5	24,2	1715	1939	14	8	27,3	11,7	701	1122
60	220	28	16	53,4	24,2	1908	2000	14	8	26,2	11,7	785	1121
62	219	28	16	53,0	24,2	1953	2015	14	8	26,0	11,7	805	1123
64	218	28	16	52,5	24,2	1999	2030	14	8	25,8	11,7	825	1125
66	217	28	16	52,1	24,2	2046	2046	14	8	25,5	11,7	846	1128
68	216	28	16	51,6	24,2	2094	2062	14	8	25,3	11,7	867	1131
70	215	28	16	51,2	24,2	2143	2079	14	8	25,1	11,7	889	1135
72	214	28	16	50,7	24,2	2192	2095	14	8	24,8	11,7	911	1139
73	214	28	16	50,5	24,2	2217	2104	14	8	24,7	11,7	922	1141
74	213	28	16	50,2	24,2	2243	2113	14	8	24,6	11,7	934	1143
76	212	28	16	49,8	24,2	2294	2130	14	8	24,4	11,7	957	1148
78	211	28	16	49,3	24,2	2346	2148	14	8	24,2	11,7	980	1153
80	210	28	16	48,9	24,2	2399	2166	14	8	23,9	11,7	1004	1159
82	209	28	16	48,4	24,2	2453	2184	14	8	23,7	11,7	1029	1165
84	208	28	16	48,0	24,2	2508	2203	14	8	23,5	11,7	1054	1171
86	207	28	16	47,5	24,2	2563	2221	14	8	23,3	11,7	1079	1177
88	206	28	16	47,1	24,2	2620	2240	14	8	23,0	11,7	1105	1184
90	205	28	16	46,6	24,2	2677	2260	14	8	22,8	11,7	1131	1191
92	204	28	16	46,2	24,2	2735	2279	14	8	22,6	11,7	1158	1198
94	203	28	16	45,8	24,2	2794	2299	14	8	22,4	11,7	1186	1206
96	202	28	16	45,3	24,2	2854	2319	14	8	22,1	11,7	1213	1213
98	201	28	16	44,9	24,2	2915	2339	14	8	21,9	11,7	1242	1221
100	200	28	16	44,4	24,2	2976	2359	14	8	21,7	11,7	1270	1229
102	199	28	16	44,0	24,2	3039	2380	14	8	21,5	11,7	1299	1238
104	198	28	16	43,5	24,2	3102	2400	14	8	21,3	11,7	1329	1246
106	197	28	16	43,1	24,2	3166	2421	14	8	21,0	11,7	1359	1255
108	196	28	16	42,7	24,2	3231	2442	14	8	20,8	11,7	1390	1263
110	195	28	16	42,2	24,2	3297	2463	14	8	20,6	11,7	1421	1272
112	194	28	16	41,8	24,2	3364	2485	14	8	20,4	11,7	1452	1281
114	193	28	16	41,4	24,2	3432	2506	14	8	20,2	11,7	1484	1291
116	192	28	16	40,9	24,2	3500	2528	14	8	19,9	11,7	1517	1300
118	191	28	16	40,5	24,2	3569	2550	14	8	19,7	11,7	1550	1309
120	190	28	16	40,1	24,2	3640	2571	14	8	19,5	11,7	1583	1319
122	189	28	16	39,6	24,2	3711	2593	14	8	19,3	11,7	1617	1329
124	188	28	16	39,2	24,2	3783	2616	14	8	19,1	11,7	1651	1339

B [mm]	H [mm]	full nailing						partial nailing					
		n <sub>H</sub>	n <sub>J</sub>	k <sub>H,1</sub>	k <sub>H,2</sub>	e <sub>1</sub> [mm]	e <sub>2</sub> [mm]	n <sub>H</sub>	n <sub>J</sub>	k <sub>H,1</sub>	k <sub>H,2</sub>	e <sub>1</sub> [mm]	e <sub>2</sub> [mm]
126	187	28	16	38,8	24,2	3855	2638	14	8	18,9	11,7	1686	1349
128	186	28	16	38,4	24,2	3929	2660	14	8	18,7	11,7	1721	1359
130	185	28	16	37,9	24,2	4004	2683	14	8	18,5	11,7	1757	1369
132	184	28	16	37,5	24,2	4079	2705	14	8	18,2	11,7	1793	1379
134	183	28	16	37,1	24,2	4155	2728	14	8	18,0	11,7	1830	1390
136	182	28	16	36,7	24,2	4232	2751	14	8	17,8	11,7	1867	1400
138	181	28	16	36,3	24,2	4310	2774	14	8	17,6	11,7	1904	1411
140	180	28	16	35,8	24,2	4389	2797	14	8	17,4	11,7	1942	1421

Table B18: Joist hanger Blank 540 (140 x 200): Form factors k<sub>H,1</sub> and k<sub>H,2</sub> and dimensions e<sub>1</sub> and e<sub>2</sub>; e<sub>J,0</sub> = 52 mm

B [mm]	H [mm]	full nailing						partial nailing					
		n <sub>H</sub>	n <sub>J</sub>	k <sub>H,1</sub>	k <sub>H,2</sub>	e <sub>1</sub> [mm]	e <sub>2</sub> [mm]	n <sub>H</sub>	n <sub>J</sub>	k <sub>H,1</sub>	k <sub>H,2</sub>	e <sub>1</sub> [mm]	e <sub>2</sub> [mm]
51	245	32	18	67,1	31,8	1912	2494	16	9	33,0	15,4	801	1496
60	240	32	18	64,8	31,8	2103	2544	16	9	31,8	15,4	883	1472
62	239	32	18	64,2	31,8	2148	2557	16	9	31,5	15,4	903	1469
64	238	32	18	63,7	31,8	2193	2571	16	9	31,3	15,4	923	1468
66	237	32	18	63,2	31,8	2240	2585	16	9	31,0	15,4	943	1467
68	236	32	18	62,7	31,8	2287	2599	16	9	30,8	15,4	964	1466
70	235	32	18	62,2	31,8	2336	2614	16	9	30,5	15,4	985	1467
72	234	32	18	61,7	31,8	2385	2630	16	9	30,3	15,4	1007	1468
73	234	32	18	61,4	31,8	2409	2638	16	9	30,1	15,4	1018	1469
74	233	32	18	61,2	31,8	2435	2646	16	9	30,0	15,4	1029	1470
76	232	32	18	60,7	31,8	2485	2663	16	9	29,7	15,4	1051	1472
78	231	32	18	60,1	31,8	2537	2680	16	9	29,5	15,4	1075	1475
80	230	32	18	59,6	31,8	2589	2697	16	9	29,2	15,4	1098	1478
82	229	32	18	59,1	31,8	2643	2715	16	9	29,0	15,4	1122	1482
84	228	32	18	58,6	31,8	2697	2733	16	9	28,7	15,4	1147	1486
86	227	32	18	58,1	31,8	2752	2752	16	9	28,5	15,4	1171	1491
88	226	32	18	57,6	31,8	2808	2771	16	9	28,2	15,4	1197	1496
90	225	32	18	57,1	31,8	2865	2790	16	9	28,0	15,4	1223	1501
92	224	32	18	56,6	31,8	2922	2810	16	9	27,7	15,4	1249	1507
94	223	32	18	56,1	31,8	2981	2830	16	9	27,5	15,4	1276	1513
96	222	32	18	55,6	31,8	3040	2850	16	9	27,2	15,4	1303	1520
98	221	32	18	55,1	31,8	3100	2871	16	9	27,0	15,4	1331	1527
100	220	32	18	54,6	31,8	3161	2891	16	9	26,7	15,4	1359	1534
102	219	32	18	54,1	31,8	3223	2912	16	9	26,5	15,4	1387	1541
104	218	32	18	53,6	31,8	3286	2934	16	9	26,2	15,4	1416	1549
106	217	32	18	53,1	31,8	3349	2955	16	9	26,0	15,4	1446	1557
108	216	32	18	52,6	31,8	3414	2977	16	9	25,7	15,4	1476	1565
110	215	32	18	52,1	31,8	3479	2999	16	9	25,5	15,4	1506	1573
112	214	32	18	51,7	31,8	3545	3021	16	9	25,2	15,4	1537	1582
114	213	32	18	51,2	31,8	3612	3044	16	9	25,0	15,4	1568	1591
116	212	32	18	50,7	31,8	3680	3067	16	9	24,8	15,4	1600	1600
118	211	32	18	50,2	31,8	3749	3090	16	9	24,5	15,4	1632	1609
120	210	32	18	49,7	31,8	3818	3113	16	9	24,3	15,4	1665	1619
122	209	32	18	49,2	31,8	3889	3136	16	9	24,0	15,4	1698	1628
124	208	32	18	48,8	31,8	3960	3159	16	9	23,8	15,4	1732	1638
126	207	32	18	48,3	31,8	4032	3183	16	9	23,6	15,4	1766	1648
128	206	32	18	47,8	31,8	4105	3207	16	9	23,3	15,4	1800	1658
130	205	32	18	47,3	31,8	4179	3231	16	9	23,1	15,4	1835	1668
132	204	32	18	46,8	31,8	4253	3255	16	9	22,8	15,4	1871	1679

B [mm]	H [mm]	full nailing						partial nailing					
		n <sub>H</sub>	n <sub>J</sub>	k <sub>H,1</sub>	k <sub>H,2</sub>	e <sub>1</sub> [mm]	e <sub>2</sub> [mm]	n <sub>H</sub>	n <sub>J</sub>	k <sub>H,1</sub>	k <sub>H,2</sub>	e <sub>1</sub> [mm]	e <sub>2</sub> [mm]
134	203	32	18	46,4	31,8	4329	3280	16	9	22,6	15,4	1907	1689
136	202	32	18	45,9	31,8	4405	3304	16	9	22,4	15,4	1943	1700
138	201	32	18	45,4	31,8	4483	3329	16	9	22,1	15,4	1980	1711
140	200	32	18	45,0	31,8	4561	3353	16	9	21,9	15,4	2017	1722

Table B19: Joist hanger Blank 580 (140 x 220): Form factors k<sub>H,1</sub> and k<sub>H,2</sub> and dimensions e<sub>1</sub> and e<sub>2</sub>; e<sub>J,0</sub> = 52 mm

B [mm]	H [mm]	full nailing						partial nailing					
		n <sub>H</sub>	n <sub>J</sub>	k <sub>H,1</sub>	k <sub>H,2</sub>	e <sub>1</sub> [mm]	e <sub>2</sub> [mm]	n <sub>H</sub>	n <sub>J</sub>	k <sub>H,1</sub>	k <sub>H,2</sub>	e <sub>1</sub> [mm]	e <sub>2</sub> [mm]
51	265	36	20	79,7	40,4	2138	3160	18	10	39,2	19,6	916	1955
60	260	36	20	77,1	40,4	2328	3191	18	10	37,9	19,6	997	1899
62	259	36	20	76,5	40,4	2372	3200	18	10	37,6	19,6	1016	1890
64	258	36	20	75,9	40,4	2417	3211	18	10	37,3	19,6	1036	1883
66	257	36	20	75,4	40,4	2464	3222	18	10	37,0	19,6	1056	1877
68	256	36	20	74,8	40,4	2511	3233	18	10	36,7	19,6	1076	1871
70	255	36	20	74,2	40,4	2558	3246	18	10	36,4	19,6	1097	1867
72	254	36	20	73,6	40,4	2607	3259	18	10	36,2	19,6	1118	1864
73	254	36	20	73,4	40,4	2632	3266	18	10	36,0	19,6	1129	1863
74	253	36	20	73,1	40,4	2657	3273	18	10	35,9	19,6	1140	1862
76	252	36	20	72,5	40,4	2707	3287	18	10	35,6	19,6	1163	1860
78	251	36	20	72,0	40,4	2758	3302	18	10	35,3	19,6	1185	1859
80	250	36	20	71,4	40,4	2810	3318	18	10	35,0	19,6	1208	1859
82	249	36	20	70,8	40,4	2863	3334	18	10	34,8	19,6	1232	1860
84	248	36	20	70,3	40,4	2917	3351	18	10	34,5	19,6	1256	1861
86	247	36	20	69,7	40,4	2972	3368	18	10	34,2	19,6	1281	1863
88	246	36	20	69,1	40,4	3027	3386	18	10	33,9	19,6	1306	1865
90	245	36	20	68,6	40,4	3084	3404	18	10	33,6	19,6	1331	1868
92	244	36	20	68,0	40,4	3141	3423	18	10	33,4	19,6	1357	1872
94	243	36	20	67,5	40,4	3199	3442	18	10	33,1	19,6	1383	1876
96	242	36	20	66,9	40,4	3258	3461	18	10	32,8	19,6	1410	1880
98	241	36	20	66,4	40,4	3317	3481	18	10	32,5	19,6	1437	1885
100	240	36	20	65,8	40,4	3378	3502	18	10	32,3	19,6	1465	1890
102	239	36	20	65,3	40,4	3439	3522	18	10	32,0	19,6	1493	1896
104	238	36	20	64,7	40,4	3502	3543	18	10	31,7	19,6	1522	1902
106	237	36	20	64,2	40,4	3565	3565	18	10	31,4	19,6	1551	1908
108	236	36	20	63,6	40,4	3629	3586	18	10	31,2	19,6	1580	1915
110	235	36	20	63,1	40,4	3693	3609	18	10	30,9	19,6	1610	1922
112	234	36	20	62,5	40,4	3759	3631	18	10	30,6	19,6	1640	1930
114	233	36	20	62,0	40,4	3826	3654	18	10	30,3	19,6	1671	1938
116	232	36	20	61,5	40,4	3893	3677	18	10	30,1	19,6	1703	1946
118	231	36	20	60,9	40,4	3961	3700	18	10	29,8	19,6	1734	1954
120	230	36	20	60,4	40,4	4030	3724	18	10	29,5	19,6	1766	1963
122	229	36	20	59,8	40,4	4100	3747	18	10	29,3	19,6	1799	1972
124	228	36	20	59,3	40,4	4171	3771	18	10	29,0	19,6	1832	1981
126	227	36	20	58,8	40,4	4242	3796	18	10	28,7	19,6	1866	1990
128	226	36	20	58,3	40,4	4315	3820	18	10	28,5	19,6	1900	2000
130	225	36	20	57,7	40,4	4388	3845	18	10	28,2	19,6	1934	2009
132	224	36	20	57,2	40,4	4462	3870	18	10	27,9	19,6	1969	2019
134	223	36	20	56,7	40,4	4537	3896	18	10	27,7	19,6	2004	2030
136	222	36	20	56,1	40,4	4613	3921	18	10	27,4	19,6	2040	2040
138	221	36	20	55,6	40,4	4690	3947	18	10	27,2	19,6	2076	2051
140	220	36	20	55,1	40,4	4767	3973	18	10	26,9	19,6	2113	2061



Table B20: Joist hanger Blank 620 (140 x 240): Form factors  $k_{H,1}$  and  $k_{H,2}$  and dimensions  $e_1$  and  $e_2$ ;  $e_{J,0} = 52$  mm

B [mm]	H [mm]	full nailing						partial nailing					
		$n_H$	$n_J$	$k_{H,1}$	$k_{H,2}$	$e_1$ [mm]	$e_2$ [mm]	$n_H$	$n_J$	$k_{H,1}$	$k_{H,2}$	$e_1$ [mm]	$e_2$ [mm]
51	285	40	22	93,2	50,0	2392	3952	20	11	45,9	24,4	1046	2510
60	280	40	22	90,4	50,0	2581	3954	20	11	44,5	24,4	1125	2411
62	279	40	22	89,8	50,0	2625	3958	20	11	44,1	24,4	1144	2395
64	278	40	22	89,1	50,0	2670	3963	20	11	43,8	24,4	1164	2380
66	277	40	22	88,5	50,0	2716	3969	20	11	43,5	24,4	1183	2367
68	276	40	22	87,9	50,0	2763	3976	20	11	43,2	24,4	1204	2355
70	275	40	22	87,3	50,0	2810	3984	20	11	42,9	24,4	1224	2344
72	274	40	22	86,6	50,0	2859	3994	20	11	42,6	24,4	1245	2335
73	274	40	22	86,3	50,0	2883	3998	20	11	42,4	24,4	1256	2331
74	273	40	22	86,0	50,0	2908	4003	20	11	42,3	24,4	1267	2327
76	272	40	22	85,4	50,0	2958	4014	20	11	42,0	24,4	1289	2320
78	271	40	22	84,8	50,0	3009	4026	20	11	41,7	24,4	1311	2314
80	270	40	22	84,2	50,0	3061	4038	20	11	41,3	24,4	1334	2309
82	269	40	22	83,5	50,0	3113	4052	20	11	41,0	24,4	1358	2305
84	268	40	22	82,9	50,0	3167	4065	20	11	40,7	24,4	1381	2302
86	267	40	22	82,3	50,0	3221	4080	20	11	40,4	24,4	1406	2300
88	266	40	22	81,7	50,0	3276	4095	20	11	40,1	24,4	1430	2299
90	265	40	22	81,1	50,0	3332	4111	20	11	39,8	24,4	1455	2298
92	264	40	22	80,5	50,0	3389	4128	20	11	39,5	24,4	1481	2298
94	263	40	22	79,9	50,0	3447	4145	20	11	39,2	24,4	1507	2299
96	262	40	22	79,3	50,0	3505	4163	20	11	38,9	24,4	1533	2300
98	261	40	22	78,6	50,0	3565	4181	20	11	38,6	24,4	1560	2302
100	260	40	22	78,0	50,0	3625	4200	20	11	38,3	24,4	1588	2305
102	259	40	22	77,4	50,0	3686	4219	20	11	38,0	24,4	1615	2308
104	258	40	22	76,8	50,0	3748	4239	20	11	37,7	24,4	1644	2311
106	257	40	22	76,2	50,0	3811	4259	20	11	37,4	24,4	1672	2315
108	256	40	22	75,6	50,0	3874	4280	20	11	37,1	24,4	1701	2320
110	255	40	22	75,0	50,0	3939	4301	20	11	36,8	24,4	1731	2325
112	254	40	22	74,4	50,0	4004	4322	20	11	36,5	24,4	1761	2331
114	253	40	22	73,8	50,0	4070	4344	20	11	36,2	24,4	1791	2337
116	252	40	22	73,3	50,0	4137	4367	20	11	35,9	24,4	1822	2343
118	251	40	22	72,7	50,0	4205	4389	20	11	35,6	24,4	1854	2350
120	250	40	22	72,1	50,0	4273	4413	20	11	35,3	24,4	1885	2357
122	249	40	22	71,5	50,0	4343	4436	20	11	35,0	24,4	1918	2364
124	248	40	22	70,9	50,0	4413	4460	20	11	34,7	24,4	1950	2372
126	247	40	22	70,3	50,0	4484	4484	20	11	34,4	24,4	1983	2380
128	246	40	22	69,7	50,0	4556	4509	20	11	34,1	24,4	2017	2388
130	245	40	22	69,1	50,0	4629	4534	20	11	33,9	24,4	2051	2397
132	244	40	22	68,6	50,0	4703	4559	20	11	33,6	24,4	2085	2406
134	243	40	22	68,0	50,0	4777	4584	20	11	33,3	24,4	2120	2415
136	242	40	22	67,4	50,0	4853	4610	20	11	33,0	24,4	2156	2425
138	241	40	22	66,8	50,0	4929	4636	20	11	32,7	24,4	2191	2435
140	240	40	22	66,3	50,0	5006	4662	20	11	32,4	24,4	2228	2445

Table B21: Joist hanger Blank 760 (140 x 260): Form factors  $k_{H,1}$  and  $k_{H,2}$  and dimensions  $e_1$  and  $e_2$ ;  $e_{J,0} = 52$  mm

B [mm]	H [mm]	full nailing						partial nailing					
		$n_H$	$n_J$	$k_{H,1}$	$k_{H,2}$	$e_1$ [mm]	$e_2$ [mm]	$n_H$	$n_J$	$k_{H,1}$	$k_{H,2}$	$e_1$ [mm]	$e_2$ [mm]
51	305	44	24	108	60,6	2674	4883	22	12	53,1	29,6	1189	3172
60	300	44	24	105	60,6	2862	4846	22	12	51,6	29,6	1268	3019

B [mm]	H [mm]	full nailing						partial nailing					
		n <sub>H</sub>	n <sub>J</sub>	k <sub>H,1</sub>	k <sub>H,2</sub>	e <sub>1</sub> [mm]	e <sub>2</sub> [mm]	n <sub>H</sub>	n <sub>J</sub>	k <sub>H,1</sub>	k <sub>H,2</sub>	e <sub>1</sub> [mm]	e <sub>2</sub> [mm]
62	299	44	24	104	60,6	2906	4843	22	12	51,2	29,6	1287	2993
64	298	44	24	103	60,6	2951	4841	22	12	50,9	29,6	1306	2968
66	297	44	24	103	60,6	2996	4840	22	12	50,5	29,6	1326	2946
68	296	44	24	102	60,6	3043	4841	22	12	50,2	29,6	1346	2925
70	295	44	24	101	60,6	3090	4843	22	12	49,9	29,6	1366	2906
72	294	44	24	101	60,6	3138	4846	22	12	49,5	29,6	1387	2889
73	294	44	24	100	60,6	3163	4848	22	12	49,3	29,6	1397	2881
74	293	44	24	100	60,6	3187	4850	22	12	49,2	29,6	1408	2874
76	292	44	24	99,3	60,6	3237	4856	22	12	48,8	29,6	1430	2860
78	291	44	24	98,6	60,6	3288	4862	22	12	48,5	29,6	1452	2847
80	290	44	24	97,9	60,6	3339	4870	22	12	48,2	29,6	1475	2836
82	289	44	24	97,3	60,6	3392	4879	22	12	47,8	29,6	1498	2826
84	288	44	24	96,6	60,6	3445	4888	22	12	47,5	29,6	1522	2818
86	287	44	24	95,9	60,6	3499	4899	22	12	47,2	29,6	1546	2810
88	286	44	24	95,3	60,6	3554	4910	22	12	46,8	29,6	1570	2803
90	285	44	24	94,6	60,6	3610	4922	22	12	46,5	29,6	1595	2798
92	284	44	24	93,9	60,6	3666	4935	22	12	46,2	29,6	1620	2793
94	283	44	24	93,3	60,6	3724	4949	22	12	45,8	29,6	1646	2790
96	282	44	24	92,6	60,6	3782	4964	22	12	45,5	29,6	1672	2787
98	281	44	24	91,9	60,6	3841	4979	22	12	45,2	29,6	1699	2785
100	280	44	24	91,3	60,6	3901	4995	22	12	44,8	29,6	1726	2783
102	279	44	24	90,6	60,6	3962	5012	22	12	44,5	29,6	1753	2783
104	278	44	24	90,0	60,6	4023	5029	22	12	44,2	29,6	1781	2783
106	277	44	24	89,3	60,6	4086	5047	22	12	43,9	29,6	1810	2784
108	276	44	24	88,7	60,6	4149	5066	22	12	43,5	29,6	1838	2785
110	275	44	24	88,0	60,6	4213	5085	22	12	43,2	29,6	1868	2787
112	274	44	24	87,4	60,6	4278	5105	22	12	42,9	29,6	1897	2790
114	273	44	24	86,7	60,6	4344	5125	22	12	42,6	29,6	1927	2793
116	272	44	24	86,1	60,6	4410	5146	22	12	42,2	29,6	1958	2797
118	271	44	24	85,4	60,6	4478	5167	22	12	41,9	29,6	1989	2801
120	270	44	24	84,8	60,6	4546	5189	22	12	41,6	29,6	2020	2806
122	269	44	24	84,1	60,6	4615	5211	22	12	41,3	29,6	2052	2811
124	268	44	24	83,5	60,6	4685	5234	22	12	41,0	29,6	2085	2817
126	267	44	24	82,9	60,6	4756	5257	22	12	40,6	29,6	2118	2823
128	266	44	24	82,2	60,6	4828	5280	22	12	40,3	29,6	2151	2830
130	265	44	24	81,6	60,6	4900	5304	22	12	40,0	29,6	2184	2837
132	264	44	24	81,0	60,6	4974	5329	22	12	39,7	29,6	2218	2844
134	263	44	24	80,3	60,6	5048	5354	22	12	39,4	29,6	2253	2852
136	262	44	24	79,7	60,6	5123	5379	22	12	39,1	29,6	2288	2860
138	261	44	24	79,1	60,6	5199	5405	22	12	38,8	29,6	2323	2868
140	260	44	24	78,4	60,6	5275	5431	22	12	38,4	29,6	2359	2877

Table B22: Joist hanger Blank 700 (140 x 280): Form factors k<sub>H,1</sub> and k<sub>H,2</sub> and dimensions e<sub>1</sub> and e<sub>2</sub>; e<sub>J,0</sub> = 52 mm

B [mm]	H [mm]	full nailing						partial nailing					
		n <sub>H</sub>	n <sub>J</sub>	k <sub>H,1</sub>	k <sub>H,2</sub>	e <sub>1</sub> [mm]	e <sub>2</sub> [mm]	n <sub>H</sub>	n <sub>J</sub>	k <sub>H,1</sub>	k <sub>H,2</sub>	e <sub>1</sub> [mm]	e <sub>2</sub> [mm]
51	325	48	26	123	72,3	2983	5967	24	13	60,8	35,4	1347	3951
60	320	48	26	120	72,3	3170	5881	24	13	59,2	35,4	1425	3732
62	319	48	26	119	72,3	3214	5867	24	13	58,8	35,4	1443	3692
64	318	48	26	119	72,3	3259	5856	24	13	58,4	35,4	1462	3656
66	317	48	26	118	72,3	3304	5846	24	13	58,0	35,4	1482	3622
68	316	48	26	117	72,3	3351	5838	24	13	57,7	35,4	1502	3591

B [mm]	H [mm]	full nailing						partial nailing					
		n <sub>H</sub>	n <sub>J</sub>	k <sub>H,1</sub>	k <sub>H,2</sub>	e <sub>1</sub> [mm]	e <sub>2</sub> [mm]	n <sub>H</sub>	n <sub>J</sub>	k <sub>H,1</sub>	k <sub>H,2</sub>	e <sub>1</sub> [mm]	e <sub>2</sub> [mm]
70	315	48	26	116	72,3	3398	5832	24	13	57,3	35,4	1522	3562
72	314	48	26	116	72,3	3446	5828	24	13	56,9	35,4	1543	3535
73	314	48	26	115	72,3	3470	5826	24	13	56,8	35,4	1553	3523
74	313	48	26	115	72,3	3495	5824	24	13	56,6	35,4	1564	3511
76	312	48	26	114	72,3	3544	5823	24	13	56,2	35,4	1585	3488
78	311	48	26	113	72,3	3595	5823	24	13	55,9	35,4	1607	3467
80	310	48	26	113	72,3	3646	5824	24	13	55,5	35,4	1630	3448
82	309	48	26	112	72,3	3698	5826	24	13	55,1	35,4	1653	3430
84	308	48	26	111	72,3	3751	5830	24	13	54,8	35,4	1676	3415
86	307	48	26	111	72,3	3805	5835	24	13	54,4	35,4	1700	3400
88	306	48	26	110	72,3	3860	5841	24	13	54,1	35,4	1724	3387
90	305	48	26	109	72,3	3915	5848	24	13	53,7	35,4	1749	3375
92	304	48	26	108	72,3	3972	5856	24	13	53,3	35,4	1774	3364
94	303	48	26	108	72,3	4029	5865	24	13	53,0	35,4	1799	3355
96	302	48	26	107	72,3	4087	5875	24	13	52,6	35,4	1825	3347
98	301	48	26	106	72,3	4146	5886	24	13	52,3	35,4	1852	3339
100	300	48	26	106	72,3	4205	5898	24	13	51,9	35,4	1879	3333
102	299	48	26	105	72,3	4266	5911	24	13	51,6	35,4	1906	3328
104	298	48	26	104	72,3	4327	5924	24	13	51,2	35,4	1934	3324
106	297	48	26	103	72,3	4390	5939	24	13	50,8	35,4	1962	3320
108	296	48	26	103	72,3	4453	5954	24	13	50,5	35,4	1990	3317
110	295	48	26	102	72,3	4516	5970	24	13	50,1	35,4	2019	3315
112	294	48	26	101	72,3	4581	5987	24	13	49,8	35,4	2049	3314
114	293	48	26	101	72,3	4647	6004	24	13	49,4	35,4	2079	3314
116	292	48	26	99,9	72,3	4713	6022	24	13	49,1	35,4	2109	3314
118	291	48	26	99,2	72,3	4780	6041	24	13	48,7	35,4	2140	3315
120	290	48	26	98,5	72,3	4848	6060	24	13	48,4	35,4	2171	3317
122	289	48	26	97,8	72,3	4917	6080	24	13	48,1	35,4	2203	3319
124	288	48	26	97,1	72,3	4987	6101	24	13	47,7	35,4	2235	3322
126	287	48	26	96,4	72,3	5057	6122	24	13	47,4	35,4	2267	3325
128	286	48	26	95,8	72,3	5129	6144	24	13	47,0	35,4	2300	3329
130	285	48	26	95,1	72,3	5201	6166	24	13	46,7	35,4	2334	3334
132	284	48	26	94,4	72,3	5274	6189	24	13	46,3	35,4	2367	3339
134	283	48	26	93,7	72,3	5348	6212	24	13	46,0	35,4	2402	3344
136	282	48	26	93,0	72,3	5423	6236	24	13	45,7	35,4	2436	3350
138	281	48	26	92,3	72,3	5498	6260	24	13	45,3	35,4	2471	3356
140	280	48	26	91,7	72,3	5575	6285	24	13	45,0	35,4	2507	3363

Table B23: Joist hanger Blank 740 (140 x 300): Form factors k<sub>H,1</sub> and k<sub>H,2</sub> and dimensions e<sub>1</sub> and e<sub>2</sub>; e<sub>J,0</sub> = 52 mm

B [mm]	H [mm]	full nailing						partial nailing					
		n <sub>H</sub>	n <sub>J</sub>	k <sub>H,1</sub>	k <sub>H,2</sub>	e <sub>1</sub> [mm]	e <sub>2</sub> [mm]	n <sub>H</sub>	n <sub>J</sub>	k <sub>H,1</sub>	k <sub>H,2</sub>	e <sub>1</sub> [mm]	e <sub>2</sub> [mm]
51	345	52	28	140	85,0	3320	7218	26	14	69,0	41,7	1518	4858
60	340	52	28	136	85,0	3506	7069	26	14	67,3	41,7	1596	4559
62	339	52	28	136	85,0	3550	7044	26	14	66,9	41,7	1614	4504
64	338	52	28	135	85,0	3595	7021	26	14	66,5	41,7	1633	4453
66	337	52	28	134	85,0	3640	7000	26	14	66,1	41,7	1652	4406
68	336	52	28	133	85,0	3686	6981	26	14	65,7	41,7	1672	4361
70	335	52	28	132	85,0	3733	6965	26	14	65,3	41,7	1692	4320
72	334	52	28	132	85,0	3781	6950	26	14	64,9	41,7	1713	4281
73	334	52	28	131	85,0	3805	6944	26	14	64,7	41,7	1723	4263
74	333	52	28	131	85,0	3830	6938	26	14	64,5	41,7	1734	4245

B [mm]	H [mm]	full nailing						partial nailing					
		n <sub>H</sub>	n <sub>J</sub>	k <sub>H,1</sub>	k <sub>H,2</sub>	e <sub>1</sub> [mm]	e <sub>2</sub> [mm]	n <sub>H</sub>	n <sub>J</sub>	k <sub>H,1</sub>	k <sub>H,2</sub>	e <sub>1</sub> [mm]	e <sub>2</sub> [mm]
76	332	52	28	130	85,0	3879	6927	26	14	64,1	41,7	1755	4212
78	331	52	28	129	85,0	3930	6918	26	14	63,7	41,7	1777	4181
80	330	52	28	129	85,0	3981	6911	26	14	63,3	41,7	1799	4152
82	329	52	28	128	85,0	4033	6905	26	14	62,9	41,7	1822	4125
84	328	52	28	127	85,0	4086	6901	26	14	62,6	41,7	1845	4100
86	327	52	28	126	85,0	4139	6899	26	14	62,2	41,7	1869	4077
88	326	52	28	125	85,0	4194	6898	26	14	61,8	41,7	1893	4056
90	325	52	28	125	85,0	4249	6898	26	14	61,4	41,7	1917	4036
92	324	52	28	124	85,0	4305	6899	26	14	61,0	41,7	1942	4018
94	323	52	28	123	85,0	4362	6902	26	14	60,6	41,7	1968	4002
96	322	52	28	122	85,0	4420	6906	26	14	60,2	41,7	1993	3987
98	321	52	28	122	85,0	4479	6912	26	14	59,9	41,7	2020	3973
100	320	52	28	121	85,0	4538	6918	26	14	59,5	41,7	2046	3960
102	319	52	28	120	85,0	4598	6925	26	14	59,1	41,7	2073	3949
104	318	52	28	119	85,0	4660	6934	26	14	58,7	41,7	2101	3939
106	317	52	28	119	85,0	4722	6944	26	14	58,3	41,7	2129	3930
108	316	52	28	118	85,0	4784	6954	26	14	58,0	41,7	2157	3922
110	315	52	28	117	85,0	4848	6966	26	14	57,6	41,7	2186	3915
112	314	52	28	116	85,0	4913	6978	26	14	57,2	41,7	2215	3909
114	313	52	28	116	85,0	4978	6991	26	14	56,8	41,7	2245	3904
116	312	52	28	115	85,0	5044	7006	26	14	56,5	41,7	2275	3900
118	311	52	28	114	85,0	5111	7021	26	14	56,1	41,7	2306	3897
120	310	52	28	113	85,0	5179	7036	26	14	55,7	41,7	2337	3894
122	309	52	28	113	85,0	5247	7053	26	14	55,3	41,7	2368	3893
124	308	52	28	112	85,0	5317	7070	26	14	55,0	41,7	2400	3892
126	307	52	28	111	85,0	5387	7088	26	14	54,6	41,7	2432	3891
128	306	52	28	110	85,0	5458	7107	26	14	54,2	41,7	2465	3892
130	305	52	28	110	85,0	5530	7127	26	14	53,9	41,7	2498	3893
132	304	52	28	109	85,0	5603	7147	26	14	53,5	41,7	2532	3895
134	303	52	28	108	85,0	5677	7168	26	14	53,1	41,7	2566	3897
136	302	52	28	107	85,0	5751	7189	26	14	52,8	41,7	2600	3900
138	301	52	28	107	85,0	5826	7211	26	14	52,4	41,7	2635	3904
140	300	52	28	106	85,0	5903	7234	26	14	52,0	41,7	2670	3908

Table B24: Joist hanger Blank 780 (140 x 320): Form factors k<sub>H,1</sub> and k<sub>H,2</sub> and dimensions e<sub>1</sub> and e<sub>2</sub>; e<sub>1,0</sub> = 52 mm

B [mm]	H [mm]	full nailing						partial nailing					
		n <sub>H</sub>	n <sub>J</sub>	k <sub>H,1</sub>	k <sub>H,2</sub>	e <sub>1</sub> [mm]	e <sub>2</sub> [mm]	n <sub>H</sub>	n <sub>J</sub>	k <sub>H,1</sub>	k <sub>H,2</sub>	e <sub>1</sub> [mm]	e <sub>2</sub> [mm]
51	365	56	30	158	98,7	3684	8650	28	15	77,8	48,5	1703	5903
60	360	56	30	154	98,7	3870	8426	28	15	75,9	48,5	1780	5509
62	359	56	30	153	98,7	3913	8386	28	15	75,5	48,5	1798	5437
64	358	56	30	152	98,7	3958	8348	28	15	75,0	48,5	1817	5368
66	357	56	30	151	98,7	4003	8314	28	15	74,6	48,5	1836	5304
68	356	56	30	150	98,7	4049	8282	28	15	74,2	48,5	1856	5245
70	355	56	30	150	98,7	4096	8253	28	15	73,8	48,5	1876	5188
72	354	56	30	149	98,7	4144	8226	28	15	73,4	48,5	1896	5136
73	354	56	30	148	98,7	4168	8214	28	15	73,1	48,5	1907	5111
74	353	56	30	148	98,7	4192	8202	28	15	72,9	48,5	1917	5086
76	352	56	30	147	98,7	4241	8180	28	15	72,5	48,5	1938	5040
78	351	56	30	146	98,7	4292	8160	28	15	72,1	48,5	1960	4997
80	350	56	30	145	98,7	4343	8143	28	15	71,7	48,5	1982	4956
82	349	56	30	145	98,7	4395	8127	28	15	71,3	48,5	2005	4918

B [mm]	H [mm]	full nailing						partial nailing					
		n <sub>H</sub>	n <sub>J</sub>	k <sub>H,1</sub>	k <sub>H,2</sub>	e <sub>1</sub> [mm]	e <sub>2</sub> [mm]	n <sub>H</sub>	n <sub>J</sub>	k <sub>H,1</sub>	k <sub>H,2</sub>	e <sub>1</sub> [mm]	e <sub>2</sub> [mm]
84	348	56	30	144	98,7	4447	8113	28	15	70,9	48,5	2028	4882
86	347	56	30	143	98,7	4501	8101	28	15	70,4	48,5	2052	4849
88	346	56	30	142	98,7	4555	8091	28	15	70,0	48,5	2075	4818
90	345	56	30	141	98,7	4610	8083	28	15	69,6	48,5	2100	4789
92	344	56	30	140	98,7	4666	8076	28	15	69,2	48,5	2125	4762
94	343	56	30	140	98,7	4723	8071	28	15	68,8	48,5	2150	4737
96	342	56	30	139	98,7	4781	8068	28	15	68,4	48,5	2175	4713
98	341	56	30	138	98,7	4839	8065	28	15	68,0	48,5	2201	4692
100	340	56	30	137	98,7	4899	8065	28	15	67,6	48,5	2228	4671
102	339	56	30	136	98,7	4959	8065	28	15	67,2	48,5	2255	4653
104	338	56	30	136	98,7	5020	8067	28	15	66,8	48,5	2282	4636
106	337	56	30	135	98,7	5081	8071	28	15	66,4	48,5	2310	4620
108	336	56	30	134	98,7	5144	8075	28	15	65,9	48,5	2338	4606
110	335	56	30	133	98,7	5208	8081	28	15	65,5	48,5	2367	4592
112	334	56	30	132	98,7	5272	8088	28	15	65,1	48,5	2396	4580
114	333	56	30	131	98,7	5337	8095	28	15	64,7	48,5	2425	4570
116	332	56	30	131	98,7	5403	8104	28	15	64,3	48,5	2455	4560
118	331	56	30	130	98,7	5470	8114	28	15	63,9	48,5	2486	4551
120	330	56	30	129	98,7	5537	8125	28	15	63,5	48,5	2517	4544
122	329	56	30	128	98,7	5606	8137	28	15	63,1	48,5	2548	4537
124	328	56	30	127	98,7	5675	8150	28	15	62,7	48,5	2579	4531
126	327	56	30	127	98,7	5745	8164	28	15	62,3	48,5	2612	4527
128	326	56	30	126	98,7	5816	8179	28	15	62,0	48,5	2644	4523
130	325	56	30	125	98,7	5888	8194	28	15	61,6	48,5	2677	4520
132	324	56	30	124	98,7	5960	8211	28	15	61,2	48,5	2710	4517
134	323	56	30	124	98,7	6034	8228	28	15	60,8	48,5	2744	4516
136	322	56	30	123	98,7	6108	8246	28	15	60,4	48,5	2778	4515
138	321	56	30	122	98,7	6183	8265	28	15	60,0	48,5	2813	4515
140	320	56	30	121	98,7	6259	8284	28	15	59,6	48,5	2848	4516

Table B25: Joist hanger Blank 560 (160 x 200): Form factors k<sub>H,1</sub> and k<sub>H,2</sub> and dimensions e<sub>1</sub> and e<sub>2</sub>; e<sub>J,0</sub> = 52 mm

B [mm]	H [mm]	full nailing						partial nailing					
		n <sub>H</sub>	n <sub>J</sub>	k <sub>H,1</sub>	k <sub>H,2</sub>	e <sub>1</sub> [mm]	e <sub>2</sub> [mm]	n <sub>H</sub>	n <sub>J</sub>	k <sub>H,1</sub>	k <sub>H,2</sub>	e <sub>1</sub> [mm]	e <sub>2</sub> [mm]
51	255	32	18	72,3	31,8	1912	2494	16	9	35,6	15,4	801	1496
60	250	32	18	70,0	31,8	2103	2544	16	9	34,4	15,4	883	1472
62	249	32	18	69,4	31,8	2148	2557	16	9	34,1	15,4	903	1469
64	248	32	18	68,9	31,8	2193	2571	16	9	33,9	15,4	923	1468
66	247	32	18	68,4	31,8	2240	2585	16	9	33,6	15,4	943	1467
68	246	32	18	67,9	31,8	2287	2599	16	9	33,4	15,4	964	1466
70	245	32	18	67,4	31,8	2336	2614	16	9	33,1	15,4	985	1467
72	244	32	18	66,8	31,8	2385	2630	16	9	32,8	15,4	1007	1468
73	244	32	18	66,6	31,8	2409	2638	16	9	32,7	15,4	1018	1469
74	243	32	18	66,3	31,8	2435	2646	16	9	32,6	15,4	1029	1470
76	242	32	18	65,8	31,8	2485	2663	16	9	32,3	15,4	1051	1472
78	241	32	18	65,3	31,8	2537	2680	16	9	32,1	15,4	1075	1475
80	240	32	18	64,8	31,8	2589	2697	16	9	31,8	15,4	1098	1478
82	239	32	18	64,2	31,8	2643	2715	16	9	31,5	15,4	1122	1482
84	238	32	18	63,7	31,8	2697	2733	16	9	31,3	15,4	1147	1486
86	237	32	18	63,2	31,8	2752	2752	16	9	31,0	15,4	1171	1491
88	236	32	18	62,7	31,8	2808	2771	16	9	30,8	15,4	1197	1496
90	235	32	18	62,2	31,8	2865	2790	16	9	30,5	15,4	1223	1501

B [mm]	H [mm]	full nailing						partial nailing					
		n <sub>H</sub>	n <sub>J</sub>	k <sub>H,1</sub>	k <sub>H,2</sub>	e <sub>1</sub> [mm]	e <sub>2</sub> [mm]	n <sub>H</sub>	n <sub>J</sub>	k <sub>H,1</sub>	k <sub>H,2</sub>	e <sub>1</sub> [mm]	e <sub>2</sub> [mm]
92	234	32	18	61,7	31,8	2922	2810	16	9	30,3	15,4	1249	1507
94	233	32	18	61,2	31,8	2981	2830	16	9	30,0	15,4	1276	1513
96	232	32	18	60,7	31,8	3040	2850	16	9	29,7	15,4	1303	1520
98	231	32	18	60,1	31,8	3100	2871	16	9	29,5	15,4	1331	1527
100	230	32	18	59,6	31,8	3161	2891	16	9	29,2	15,4	1359	1534
102	229	32	18	59,1	31,8	3223	2912	16	9	29,0	15,4	1387	1541
104	228	32	18	58,6	31,8	3286	2934	16	9	28,7	15,4	1416	1549
106	227	32	18	58,1	31,8	3349	2955	16	9	28,5	15,4	1446	1557
108	226	32	18	57,6	31,8	3414	2977	16	9	28,2	15,4	1476	1565
110	225	32	18	57,1	31,8	3479	2999	16	9	28,0	15,4	1506	1573
112	224	32	18	56,6	31,8	3545	3021	16	9	27,7	15,4	1537	1582
114	223	32	18	56,1	31,8	3612	3044	16	9	27,5	15,4	1568	1591
116	222	32	18	55,6	31,8	3680	3067	16	9	27,2	15,4	1600	1600
118	221	32	18	55,1	31,8	3749	3090	16	9	27,0	15,4	1632	1609
120	220	32	18	54,6	31,8	3818	3113	16	9	26,7	15,4	1665	1619
122	219	32	18	54,1	31,8	3889	3136	16	9	26,5	15,4	1698	1628
124	218	32	18	53,6	31,8	3960	3159	16	9	26,2	15,4	1732	1638
126	217	32	18	53,1	31,8	4032	3183	16	9	26,0	15,4	1766	1648
128	216	32	18	52,6	31,8	4105	3207	16	9	25,7	15,4	1800	1658
130	215	32	18	52,1	31,8	4179	3231	16	9	25,5	15,4	1835	1668
132	214	32	18	51,7	31,8	4253	3255	16	9	25,2	15,4	1871	1679
134	213	32	18	51,2	31,8	4329	3280	16	9	25,0	15,4	1907	1689
136	212	32	18	50,7	31,8	4405	3304	16	9	24,8	15,4	1943	1700
138	211	32	18	50,2	31,8	4483	3329	16	9	24,5	15,4	1980	1711
140	210	32	18	49,7	31,8	4561	3353	16	9	24,3	15,4	2017	1722
142	209	32	18	49,2	31,8	4640	3378	16	9	24,0	15,4	2055	1733
144	208	32	18	48,8	31,8	4719	3403	16	9	23,8	15,4	2093	1744
146	207	32	18	48,3	31,8	4800	3429	16	9	23,6	15,4	2131	1755
148	206	32	18	47,8	31,8	4881	3454	16	9	23,3	15,4	2171	1767
150	205	32	18	47,3	31,8	4964	3479	16	9	23,1	15,4	2210	1778
152	204	32	18	46,8	31,8	5047	3505	16	9	22,8	15,4	2250	1790
154	203	32	18	46,4	31,8	5131	3531	16	9	22,6	15,4	2291	1802
156	202	32	18	45,9	31,8	5216	3556	16	9	22,4	15,4	2331	1813
158	201	32	18	45,4	31,8	5302	3582	16	9	22,1	15,4	2373	1825
160	200	32	18	45,0	31,8	5388	3608	16	9	21,9	15,4	2415	1837

Table B26: Joist hanger Blank 600 (160 x 220): Form factors k<sub>H,1</sub> and k<sub>H,2</sub> and dimensions e<sub>1</sub> and e<sub>2</sub>; e<sub>J,0</sub> = 52 mm

B [mm]	H [mm]	full nailing						partial nailing					
		n <sub>H</sub>	n <sub>J</sub>	k <sub>H,1</sub>	k <sub>H,2</sub>	e <sub>1</sub> [mm]	e <sub>2</sub> [mm]	n <sub>H</sub>	n <sub>J</sub>	k <sub>H,1</sub>	k <sub>H,2</sub>	e <sub>1</sub> [mm]	e <sub>2</sub> [mm]
51	275	36	20	85,5	40,4	2138	3160	18	10	42,1	19,6	916	1955
60	270	36	20	82,8	40,4	2328	3191	18	10	40,8	19,6	997	1899
62	269	36	20	82,3	40,4	2372	3200	18	10	40,5	19,6	1016	1890
64	268	36	20	81,7	40,4	2417	3211	18	10	40,2	19,6	1036	1883
66	267	36	20	81,1	40,4	2464	3222	18	10	39,9	19,6	1056	1877
68	266	36	20	80,5	40,4	2511	3233	18	10	39,6	19,6	1076	1871
70	265	36	20	79,9	40,4	2558	3246	18	10	39,3	19,6	1097	1867
72	264	36	20	79,4	40,4	2607	3259	18	10	39,0	19,6	1118	1864
73	264	36	20	79,1	40,4	2632	3266	18	10	38,9	19,6	1129	1863
74	263	36	20	78,8	40,4	2657	3273	18	10	38,7	19,6	1140	1862
76	262	36	20	78,2	40,4	2707	3287	18	10	38,5	19,6	1163	1860
78	261	36	20	77,6	40,4	2758	3302	18	10	38,2	19,6	1185	1859

B [mm]	H [mm]	full nailing						partial nailing					
		n <sub>H</sub>	n <sub>J</sub>	k <sub>H,1</sub>	k <sub>H,2</sub>	e <sub>1</sub> [mm]	e <sub>2</sub> [mm]	n <sub>H</sub>	n <sub>J</sub>	k <sub>H,1</sub>	k <sub>H,2</sub>	e <sub>1</sub> [mm]	e <sub>2</sub> [mm]
80	260	36	20	77,1	40,4	2810	3318	18	10	37,9	19,6	1208	1859
82	259	36	20	76,5	40,4	2863	3334	18	10	37,6	19,6	1232	1860
84	258	36	20	75,9	40,4	2917	3351	18	10	37,3	19,6	1256	1861
86	257	36	20	75,4	40,4	2972	3368	18	10	37,0	19,6	1281	1863
88	256	36	20	74,8	40,4	3027	3386	18	10	36,7	19,6	1306	1865
90	255	36	20	74,2	40,4	3084	3404	18	10	36,4	19,6	1331	1868
92	254	36	20	73,6	40,4	3141	3423	18	10	36,2	19,6	1357	1872
94	253	36	20	73,1	40,4	3199	3442	18	10	35,9	19,6	1383	1876
96	252	36	20	72,5	40,4	3258	3461	18	10	35,6	19,6	1410	1880
98	251	36	20	72,0	40,4	3317	3481	18	10	35,3	19,6	1437	1885
100	250	36	20	71,4	40,4	3378	3502	18	10	35,0	19,6	1465	1890
102	249	36	20	70,8	40,4	3439	3522	18	10	34,8	19,6	1493	1896
104	248	36	20	70,3	40,4	3502	3543	18	10	34,5	19,6	1522	1902
106	247	36	20	69,7	40,4	3565	3565	18	10	34,2	19,6	1551	1908
108	246	36	20	69,1	40,4	3629	3586	18	10	33,9	19,6	1580	1915
110	245	36	20	68,6	40,4	3693	3609	18	10	33,6	19,6	1610	1922
112	244	36	20	68,0	40,4	3759	3631	18	10	33,4	19,6	1640	1930
114	243	36	20	67,5	40,4	3826	3654	18	10	33,1	19,6	1671	1938
116	242	36	20	66,9	40,4	3893	3677	18	10	32,8	19,6	1703	1946
118	241	36	20	66,4	40,4	3961	3700	18	10	32,5	19,6	1734	1954
120	240	36	20	65,8	40,4	4030	3724	18	10	32,3	19,6	1766	1963
122	239	36	20	65,3	40,4	4100	3747	18	10	32,0	19,6	1799	1972
124	238	36	20	64,7	40,4	4171	3771	18	10	31,7	19,6	1832	1981
126	237	36	20	64,2	40,4	4242	3796	18	10	31,4	19,6	1866	1990
128	236	36	20	63,6	40,4	4315	3820	18	10	31,2	19,6	1900	2000
130	235	36	20	63,1	40,4	4388	3845	18	10	30,9	19,6	1934	2009
132	234	36	20	62,5	40,4	4462	3870	18	10	30,6	19,6	1969	2019
134	233	36	20	62,0	40,4	4537	3896	18	10	30,3	19,6	2004	2030
136	232	36	20	61,5	40,4	4613	3921	18	10	30,1	19,6	2040	2040
138	231	36	20	60,9	40,4	4690	3947	18	10	29,8	19,6	2076	2051
140	230	36	20	60,4	40,4	4767	3973	18	10	29,5	19,6	2113	2061
142	229	36	20	59,8	40,4	4845	3999	18	10	29,3	19,6	2150	2072
144	228	36	20	59,3	40,4	4925	4025	18	10	29,0	19,6	2188	2083
146	227	36	20	58,8	40,4	5005	4051	18	10	28,7	19,6	2226	2095
148	226	36	20	58,3	40,4	5086	4078	18	10	28,5	19,6	2264	2106
150	225	36	20	57,7	40,4	5167	4105	18	10	28,2	19,6	2303	2118
152	224	36	20	57,2	40,4	5250	4132	18	10	27,9	19,6	2342	2129
154	223	36	20	56,7	40,4	5333	4159	18	10	27,7	19,6	2382	2141
156	222	36	20	56,1	40,4	5418	4186	18	10	27,4	19,6	2423	2153
158	221	36	20	55,6	40,4	5503	4214	18	10	27,2	19,6	2463	2165
160	220	36	20	55,1	40,4	5589	4241	18	10	26,9	19,6	2504	2178

Table B27: Joist hanger Blank 640 (160 x 240): Form factors k<sub>H,1</sub> and k<sub>H,2</sub> and dimensions e<sub>1</sub> and e<sub>2</sub>; e<sub>J,0</sub> = 52 mm

B [mm]	H [mm]	full nailing						partial nailing					
		n <sub>H</sub>	n <sub>J</sub>	k <sub>H,1</sub>	k <sub>H,2</sub>	e <sub>1</sub> [mm]	e <sub>2</sub> [mm]	n <sub>H</sub>	n <sub>J</sub>	k <sub>H,1</sub>	k <sub>H,2</sub>	e <sub>1</sub> [mm]	e <sub>2</sub> [mm]
51	295	40	22	99,6	50,0	2392	3952	20	11	49,1	24,4	1046	2510
60	290	40	22	96,7	50,0	2581	3954	20	11	47,6	24,4	1125	2411
62	289	40	22	96,1	50,0	2625	3958	20	11	47,3	24,4	1144	2395
64	288	40	22	95,4	50,0	2670	3963	20	11	47,0	24,4	1164	2380
66	287	40	22	94,8	50,0	2716	3969	20	11	46,7	24,4	1183	2367
68	286	40	22	94,2	50,0	2763	3976	20	11	46,4	24,4	1204	2355

B [mm]	H [mm]	full nailing						partial nailing					
		n <sub>H</sub>	n <sub>J</sub>	k <sub>H,1</sub>	k <sub>H,2</sub>	e <sub>1</sub> [mm]	e <sub>2</sub> [mm]	n <sub>H</sub>	n <sub>J</sub>	k <sub>H,1</sub>	k <sub>H,2</sub>	e <sub>1</sub> [mm]	e <sub>2</sub> [mm]
70	285	40	22	93,5	50,0	2810	3984	20	11	46,0	24,4	1224	2344
72	284	40	22	92,9	50,0	2859	3994	20	11	45,7	24,4	1245	2335
73	284	40	22	92,6	50,0	2883	3998	20	11	45,6	24,4	1256	2331
74	283	40	22	92,3	50,0	2908	4003	20	11	45,4	24,4	1267	2327
76	282	40	22	91,6	50,0	2958	4014	20	11	45,1	24,4	1289	2320
78	281	40	22	91,0	50,0	3009	4026	20	11	44,8	24,4	1311	2314
80	280	40	22	90,4	50,0	3061	4038	20	11	44,5	24,4	1334	2309
82	279	40	22	89,8	50,0	3113	4052	20	11	44,1	24,4	1358	2305
84	278	40	22	89,1	50,0	3167	4065	20	11	43,8	24,4	1381	2302
86	277	40	22	88,5	50,0	3221	4080	20	11	43,5	24,4	1406	2300
88	276	40	22	87,9	50,0	3276	4095	20	11	43,2	24,4	1430	2299
90	275	40	22	87,3	50,0	3332	4111	20	11	42,9	24,4	1455	2298
92	274	40	22	86,6	50,0	3389	4128	20	11	42,6	24,4	1481	2298
94	273	40	22	86,0	50,0	3447	4145	20	11	42,3	24,4	1507	2299
96	272	40	22	85,4	50,0	3505	4163	20	11	42,0	24,4	1533	2300
98	271	40	22	84,8	50,0	3565	4181	20	11	41,7	24,4	1560	2302
100	270	40	22	84,2	50,0	3625	4200	20	11	41,3	24,4	1588	2305
102	269	40	22	83,5	50,0	3686	4219	20	11	41,0	24,4	1615	2308
104	268	40	22	82,9	50,0	3748	4239	20	11	40,7	24,4	1644	2311
106	267	40	22	82,3	50,0	3811	4259	20	11	40,4	24,4	1672	2315
108	266	40	22	81,7	50,0	3874	4280	20	11	40,1	24,4	1701	2320
110	265	40	22	81,1	50,0	3939	4301	20	11	39,8	24,4	1731	2325
112	264	40	22	80,5	50,0	4004	4322	20	11	39,5	24,4	1761	2331
114	263	40	22	79,9	50,0	4070	4344	20	11	39,2	24,4	1791	2337
116	262	40	22	79,3	50,0	4137	4367	20	11	38,9	24,4	1822	2343
118	261	40	22	78,6	50,0	4205	4389	20	11	38,6	24,4	1854	2350
120	260	40	22	78,0	50,0	4273	4413	20	11	38,3	24,4	1885	2357
122	259	40	22	77,4	50,0	4343	4436	20	11	38,0	24,4	1918	2364
124	258	40	22	76,8	50,0	4413	4460	20	11	37,7	24,4	1950	2372
126	257	40	22	76,2	50,0	4484	4484	20	11	37,4	24,4	1983	2380
128	256	40	22	75,6	50,0	4556	4509	20	11	37,1	24,4	2017	2388
130	255	40	22	75,0	50,0	4629	4534	20	11	36,8	24,4	2051	2397
132	254	40	22	74,4	50,0	4703	4559	20	11	36,5	24,4	2085	2406
134	253	40	22	73,8	50,0	4777	4584	20	11	36,2	24,4	2120	2415
136	252	40	22	73,3	50,0	4853	4610	20	11	35,9	24,4	2156	2425
138	251	40	22	72,7	50,0	4929	4636	20	11	35,6	24,4	2191	2435
140	250	40	22	72,1	50,0	5006	4662	20	11	35,3	24,4	2228	2445
142	249	40	22	71,5	50,0	5084	4689	20	11	35,0	24,4	2264	2455
144	248	40	22	70,9	50,0	5163	4716	20	11	34,7	24,4	2301	2466
146	247	40	22	70,3	50,0	5242	4743	20	11	34,4	24,4	2339	2476
148	246	40	22	69,7	50,0	5323	4770	20	11	34,1	24,4	2377	2487
150	245	40	22	69,1	50,0	5404	4798	20	11	33,9	24,4	2415	2499
152	244	40	22	68,6	50,0	5486	4826	20	11	33,6	24,4	2454	2510
154	243	40	22	68,0	50,0	5569	4854	20	11	33,3	24,4	2494	2522
156	242	40	22	67,4	50,0	5653	4882	20	11	33,0	24,4	2533	2533
158	241	40	22	66,8	50,0	5737	4910	20	11	32,7	24,4	2574	2545
160	240	40	22	66,3	50,0	5823	4939	20	11	32,4	24,4	2614	2557



Table B28: Joist hanger Blank 680 (160 x 260): Form factors  $k_{H,1}$  and  $k_{H,2}$  and dimensions  $e_1$  and  $e_2$ ;  $e_{J,0} = 52$  mm

B [mm]	H [mm]	full nailing						partial nailing					
		$n_H$	$n_J$	$k_{H,1}$	$k_{H,2}$	$e_1$ [mm]	$e_2$ [mm]	$n_H$	$n_J$	$k_{H,1}$	$k_{H,2}$	$e_1$ [mm]	$e_2$ [mm]
51	315	44	24	115	60,6	2674	4883	22	12	56,6	29,6	1189	3172
60	310	44	24	112	60,6	2862	4846	22	12	55,0	29,6	1268	3019
62	309	44	24	111	60,6	2906	4843	22	12	54,7	29,6	1287	2993
64	308	44	24	110	60,6	2951	4841	22	12	54,3	29,6	1306	2968
66	307	44	24	110	60,6	2996	4840	22	12	54,0	29,6	1326	2946
68	306	44	24	109	60,6	3043	4841	22	12	53,6	29,6	1346	2925
70	305	44	24	108	60,6	3090	4843	22	12	53,3	29,6	1366	2906
72	304	44	24	107	60,6	3138	4846	22	12	52,9	29,6	1387	2889
73	304	44	24	107	60,6	3163	4848	22	12	52,8	29,6	1397	2881
74	303	44	24	107	60,6	3187	4850	22	12	52,6	29,6	1408	2874
76	302	44	24	106	60,6	3237	4856	22	12	52,2	29,6	1430	2860
78	301	44	24	105	60,6	3288	4862	22	12	51,9	29,6	1452	2847
80	300	44	24	105	60,6	3339	4870	22	12	51,6	29,6	1475	2836
82	299	44	24	104	60,6	3392	4879	22	12	51,2	29,6	1498	2826
84	298	44	24	103	60,6	3445	4888	22	12	50,9	29,6	1522	2818
86	297	44	24	103	60,6	3499	4899	22	12	50,5	29,6	1546	2810
88	296	44	24	102	60,6	3554	4910	22	12	50,2	29,6	1570	2803
90	295	44	24	101	60,6	3610	4922	22	12	49,9	29,6	1595	2798
92	294	44	24	101	60,6	3666	4935	22	12	49,5	29,6	1620	2793
94	293	44	24	100	60,6	3724	4949	22	12	49,2	29,6	1646	2790
96	292	44	24	99,3	60,6	3782	4964	22	12	48,8	29,6	1672	2787
98	291	44	24	98,6	60,6	3841	4979	22	12	48,5	29,6	1699	2785
100	290	44	24	97,9	60,6	3901	4995	22	12	48,2	29,6	1726	2783
102	289	44	24	97,3	60,6	3962	5012	22	12	47,8	29,6	1753	2783
104	288	44	24	96,6	60,6	4023	5029	22	12	47,5	29,6	1781	2783
106	287	44	24	95,9	60,6	4086	5047	22	12	47,2	29,6	1810	2784
108	286	44	24	95,3	60,6	4149	5066	22	12	46,8	29,6	1838	2785
110	285	44	24	94,6	60,6	4213	5085	22	12	46,5	29,6	1868	2787
112	284	44	24	93,9	60,6	4278	5105	22	12	46,2	29,6	1897	2790
114	283	44	24	93,3	60,6	4344	5125	22	12	45,8	29,6	1927	2793
116	282	44	24	92,6	60,6	4410	5146	22	12	45,5	29,6	1958	2797
118	281	44	24	91,9	60,6	4478	5167	22	12	45,2	29,6	1989	2801
120	280	44	24	91,3	60,6	4546	5189	22	12	44,8	29,6	2020	2806
122	279	44	24	90,6	60,6	4615	5211	22	12	44,5	29,6	2052	2811
124	278	44	24	90,0	60,6	4685	5234	22	12	44,2	29,6	2085	2817
126	277	44	24	89,3	60,6	4756	5257	22	12	43,9	29,6	2118	2823
128	276	44	24	88,7	60,6	4828	5280	22	12	43,5	29,6	2151	2830
130	275	44	24	88,0	60,6	4900	5304	22	12	43,2	29,6	2184	2837
132	274	44	24	87,4	60,6	4974	5329	22	12	42,9	29,6	2218	2844
134	273	44	24	86,7	60,6	5048	5354	22	12	42,6	29,6	2253	2852
136	272	44	24	86,1	60,6	5123	5379	22	12	42,2	29,6	2288	2860
138	271	44	24	85,4	60,6	5199	5405	22	12	41,9	29,6	2323	2868
140	270	44	24	84,8	60,6	5275	5431	22	12	41,6	29,6	2359	2877
142	269	44	24	84,1	60,6	5353	5457	22	12	41,3	29,6	2396	2886
144	268	44	24	83,5	60,6	5431	5484	22	12	41,0	29,6	2432	2896
146	267	44	24	82,9	60,6	5510	5510	22	12	40,6	29,6	2470	2905
148	266	44	24	82,2	60,6	5591	5538	22	12	40,3	29,6	2507	2915
150	265	44	24	81,6	60,6	5671	5565	22	12	40,0	29,6	2545	2925
152	264	44	24	81,0	60,6	5753	5593	22	12	39,7	29,6	2584	2936
154	263	44	24	80,3	60,6	5836	5622	22	12	39,4	29,6	2623	2947
156	262	44	24	79,7	60,6	5919	5650	22	12	39,1	29,6	2662	2958

B [mm]	H [mm]	full nailing						partial nailing					
		n <sub>H</sub>	n <sub>J</sub>	k <sub>H,1</sub>	k <sub>H,2</sub>	e <sub>1</sub> [mm]	e <sub>2</sub> [mm]	n <sub>H</sub>	n <sub>J</sub>	k <sub>H,1</sub>	k <sub>H,2</sub>	e <sub>1</sub> [mm]	e <sub>2</sub> [mm]
158	261	44	24	79,1	60,6	6003	5679	22	12	38,8	29,6	2702	2969
160	260	44	24	78,4	60,6	6088	5708	22	12	38,4	29,6	2742	2981

Table B29: Joist hanger Blank 720 (160 x 280): Form factors k<sub>H,1</sub> and k<sub>H,2</sub> and dimensions e<sub>1</sub> and e<sub>2</sub>; e<sub>J,0</sub> = 52 mm

B [mm]	H [mm]	full nailing						partial nailing					
		n <sub>H</sub>	n <sub>J</sub>	k <sub>H,1</sub>	k <sub>H,2</sub>	e <sub>1</sub> [mm]	e <sub>2</sub> [mm]	n <sub>H</sub>	n <sub>J</sub>	k <sub>H,1</sub>	k <sub>H,2</sub>	e <sub>1</sub> [mm]	e <sub>2</sub> [mm]
51	334,5	48	26	131	72,31	2983	5967	24	13	64,57	35,38	1347	3951
60	330	48	26	127	72,31	3170	5881	24	13	62,87	35,38	1425	3732
62	329	48	26	127	72,31	3214	5867	24	13	62,50	35,38	1443	3692
64	328	48	26	126	72,31	3259	5856	24	13	62,12	35,38	1462	3656
66	327	48	26	125	72,31	3304	5846	24	13	61,75	35,38	1482	3622
68	326	48	26	125	72,31	3351	5838	24	13	61,38	35,38	1502	3591
70	325	48	26	124	72,31	3398	5832	24	13	61,00	35,38	1522	3562
72	324	48	26	123	72,31	3446	5828	24	13	60,63	35,38	1543	3535
73	323,5	48	26	123	72,31	3470	5826	24	13	60,45	35,38	1553	3523
74	323	48	26	122	72,31	3495	5824	24	13	60,26	35,38	1564	3511
76	322	48	26	122	72,31	3544	5823	24	13	59,89	35,38	1585	3488
78	321	48	26	121	72,31	3595	5823	24	13	59,52	35,38	1607	3467
80	320	48	26	120	72,31	3646	5824	24	13	59,15	35,38	1630	3448
82	319	48	26	119	72,31	3698	5826	24	13	58,78	35,38	1653	3430
84	318	48	26	119	72,31	3751	5830	24	13	58,41	35,38	1676	3415
86	317	48	26	118	72,31	3805	5835	24	13	58,05	35,38	1700	3400
88	316	48	26	117	72,31	3860	5841	24	13	57,68	35,38	1724	3387
90	315	48	26	116	72,31	3915	5848	24	13	57,31	35,38	1749	3375
92	314	48	26	116	72,31	3972	5856	24	13	56,95	35,38	1774	3364
94	313	48	26	115	72,31	4029	5865	24	13	56,58	35,38	1799	3355
96	312	48	26	114	72,31	4087	5875	24	13	56,22	35,38	1825	3347
98	311	48	26	113	72,31	4146	5886	24	13	55,86	35,38	1852	3339
100	310	48	26	113	72,31	4205	5898	24	13	55,49	35,38	1879	3333
102	309	48	26	112	72,31	4266	5911	24	13	55,13	35,38	1906	3328
104	308	48	26	111	72,31	4327	5924	24	13	54,77	35,38	1934	3324
106	307	48	26	111	72,31	4390	5939	24	13	54,41	35,38	1962	3320
108	306	48	26	110	72,31	4453	5954	24	13	54,05	35,38	1990	3317
110	305	48	26	109	72,31	4516	5970	24	13	53,69	35,38	2019	3315
112	304	48	26	108	72,31	4581	5987	24	13	53,33	35,38	2049	3314
114	303	48	26	108	72,31	4647	6004	24	13	52,98	35,38	2079	3314
116	302	48	26	107	72,31	4713	6022	24	13	52,62	35,38	2109	3314
118	301	48	26	106	72,31	4780	6041	24	13	52,26	35,38	2140	3315
120	300	48	26	106	72,31	4848	6060	24	13	51,91	35,38	2171	3317
122	299	48	26	105	72,31	4917	6080	24	13	51,55	35,38	2203	3319
124	298	48	26	104	72,31	4987	6101	24	13	51,20	35,38	2235	3322
126	297	48	26	103	72,31	5057	6122	24	13	50,85	35,38	2267	3325
128	296	48	26	103	72,31	5129	6144	24	13	50,50	35,38	2300	3329
130	295	48	26	102	72,31	5201	6166	24	13	50,15	35,38	2334	3334
132	294	48	26	101	72,31	5274	6189	24	13	49,79	35,38	2367	3339
134	293	48	26	101	72,31	5348	6212	24	13	49,45	35,38	2402	3344
136	292	48	26	99,91	72,31	5423	6236	24	13	49,10	35,38	2436	3350
138	291	48	26	99,21	72,31	5498	6260	24	13	48,75	35,38	2471	3356
140	290	48	26	98,52	72,31	5575	6285	24	13	48,40	35,38	2507	3363
142	289	48	26	97,82	72,31	5652	6310	24	13	48,06	35,38	2543	3370
144	288	48	26	97,13	72,31	5730	6336	24	13	47,71	35,38	2579	3378

B [mm]	H [mm]	full nailing						partial nailing					
		n <sub>H</sub>	n <sub>J</sub>	k <sub>H,1</sub>	k <sub>H,2</sub>	e <sub>1</sub> [mm]	e <sub>2</sub> [mm]	n <sub>H</sub>	n <sub>J</sub>	k <sub>H,1</sub>	k <sub>H,2</sub>	e <sub>1</sub> [mm]	e <sub>2</sub> [mm]
146	287	48	26	96,44	72,31	5809	6362	24	13	47,37	35,38	2616	3386
148	286	48	26	95,75	72,31	5888	6388	24	13	47,02	35,38	2654	3394
150	285	48	26	95,07	72,31	5969	6415	24	13	46,68	35,38	2691	3403
152	284	48	26	94,38	72,31	6050	6443	24	13	46,34	35,38	2730	3412
154	283	48	26	93,70	72,31	6133	6470	24	13	46,00	35,38	2768	3421
156	282	48	26	93,01	72,31	6216	6498	24	13	45,66	35,38	2807	3431
158	281	48	26	92,33	72,31	6300	6527	24	13	45,32	35,38	2847	3441
160	280	48	26	91,66	72,31	6384	6555	24	13	44,98	35,38	2887	3451

Table B30: Joist hanger Blank 760 (160 x 300): Form factors k<sub>H,1</sub> and k<sub>H,2</sub> and dimensions e<sub>1</sub> and e<sub>2</sub>; e<sub>J,0</sub> = 52 mm

B [mm]	H [mm]	full nailing						partial nailing					
		n <sub>H</sub>	n <sub>J</sub>	k <sub>H,1</sub>	k <sub>H,2</sub>	e <sub>1</sub> [mm]	e <sub>2</sub> [mm]	n <sub>H</sub>	n <sub>J</sub>	k <sub>H,1</sub>	k <sub>H,2</sub>	e <sub>1</sub> [mm]	e <sub>2</sub> [mm]
51	355	52	28	148	85,0	3320	7218	26	14	73,1	41,7	1518	4858
60	350	52	28	144	85,0	3506	7069	26	14	71,3	41,7	1596	4559
62	349	52	28	144	85,0	3550	7044	26	14	70,8	41,7	1614	4504
64	348	52	28	143	85,0	3595	7021	26	14	70,4	41,7	1633	4453
66	347	52	28	142	85,0	3640	7000	26	14	70,0	41,7	1652	4406
68	346	52	28	141	85,0	3686	6981	26	14	69,6	41,7	1672	4361
70	345	52	28	140	85,0	3733	6965	26	14	69,2	41,7	1692	4320
72	344	52	28	140	85,0	3781	6950	26	14	68,8	41,7	1713	4281
73	344	52	28	139	85,0	3805	6944	26	14	68,6	41,7	1723	4263
74	343	52	28	139	85,0	3830	6938	26	14	68,4	41,7	1734	4245
76	342	52	28	138	85,0	3879	6927	26	14	68,1	41,7	1755	4212
78	341	52	28	137	85,0	3930	6918	26	14	67,7	41,7	1777	4181
80	340	52	28	136	85,0	3981	6911	26	14	67,3	41,7	1799	4152
82	339	52	28	136	85,0	4033	6905	26	14	66,9	41,7	1822	4125
84	338	52	28	135	85,0	4086	6901	26	14	66,5	41,7	1845	4100
86	337	52	28	134	85,0	4139	6899	26	14	66,1	41,7	1869	4077
88	336	52	28	133	85,0	4194	6898	26	14	65,7	41,7	1893	4056
90	335	52	28	132	85,0	4249	6898	26	14	65,3	41,7	1917	4036
92	334	52	28	132	85,0	4305	6899	26	14	64,9	41,7	1942	4018
94	333	52	28	131	85,0	4362	6902	26	14	64,5	41,7	1968	4002
96	332	52	28	130	85,0	4420	6906	26	14	64,1	41,7	1993	3987
98	331	52	28	129	85,0	4479	6912	26	14	63,7	41,7	2020	3973
100	330	52	28	129	85,0	4538	6918	26	14	63,3	41,7	2046	3960
102	329	52	28	128	85,0	4598	6925	26	14	62,9	41,7	2073	3949
104	328	52	28	127	85,0	4660	6934	26	14	62,6	41,7	2101	3939
106	327	52	28	126	85,0	4722	6944	26	14	62,2	41,7	2129	3930
108	326	52	28	125	85,0	4784	6954	26	14	61,8	41,7	2157	3922
110	325	52	28	125	85,0	4848	6966	26	14	61,4	41,7	2186	3915
112	324	52	28	124	85,0	4913	6978	26	14	61,0	41,7	2215	3909
114	323	52	28	123	85,0	4978	6991	26	14	60,6	41,7	2245	3904
116	322	52	28	122	85,0	5044	7006	26	14	60,2	41,7	2275	3900
118	321	52	28	122	85,0	5111	7021	26	14	59,9	41,7	2306	3897
120	320	52	28	121	85,0	5179	7036	26	14	59,5	41,7	2337	3894
122	319	52	28	120	85,0	5247	7053	26	14	59,1	41,7	2368	3893
124	318	52	28	119	85,0	5317	7070	26	14	58,7	41,7	2400	3892
126	317	52	28	119	85,0	5387	7088	26	14	58,3	41,7	2432	3891
128	316	52	28	118	85,0	5458	7107	26	14	58,0	41,7	2465	3892
130	315	52	28	117	85,0	5530	7127	26	14	57,6	41,7	2498	3893
132	314	52	28	116	85,0	5603	7147	26	14	57,2	41,7	2532	3895

B [mm]	H [mm]	full nailing						partial nailing					
		n <sub>H</sub>	n <sub>J</sub>	k <sub>H,1</sub>	k <sub>H,2</sub>	e <sub>1</sub> [mm]	e <sub>2</sub> [mm]	n <sub>H</sub>	n <sub>J</sub>	k <sub>H,1</sub>	k <sub>H,2</sub>	e <sub>1</sub> [mm]	e <sub>2</sub> [mm]
134	313	52	28	116	85,0	5677	7168	26	14	56,8	41,7	2566	3897
136	312	52	28	115	85,0	5751	7189	26	14	56,5	41,7	2600	3900
138	311	52	28	114	85,0	5826	7211	26	14	56,1	41,7	2635	3904
140	310	52	28	113	85,0	5903	7234	26	14	55,7	41,7	2670	3908
142	309	52	28	113	85,0	5980	7257	26	14	55,3	41,7	2706	3912
144	308	52	28	112	85,0	6057	7281	26	14	55,0	41,7	2742	3917
146	307	52	28	111	85,0	6136	7305	26	14	54,6	41,7	2779	3923
148	306	52	28	110	85,0	6215	7330	26	14	54,2	41,7	2816	3929
150	305	52	28	110	85,0	6296	7355	26	14	53,9	41,7	2853	3936
152	304	52	28	109	85,0	6377	7381	26	14	53,5	41,7	2891	3943
154	303	52	28	108	85,0	6459	7407	26	14	53,1	41,7	2930	3950
156	302	52	28	107	85,0	6542	7434	26	14	52,8	41,7	2968	3958
158	301	52	28	107	85,0	6625	7461	26	14	52,4	41,7	3008	3966
160	300	52	28	106	85,0	6710	7488	26	14	52,0	41,7	3047	3975

Table B31: Joist hanger Blank 800 (160 x 320): Form factors k<sub>H,1</sub> and k<sub>H,2</sub> and dimensions e<sub>1</sub> and e<sub>2</sub>; e<sub>J,0</sub> = 52 mm

B [mm]	H [mm]	full nailing						partial nailing					
		n <sub>H</sub>	n <sub>J</sub>	k <sub>H,1</sub>	k <sub>H,2</sub>	e <sub>1</sub> [mm]	e <sub>2</sub> [mm]	n <sub>H</sub>	n <sub>J</sub>	k <sub>H,1</sub>	k <sub>H,2</sub>	e <sub>1</sub> [mm]	e <sub>2</sub> [mm]
51	375	56	30	166	98,7	3684	8650	28	15	82,1	48,5	1703	5903
60	370	56	30	162	98,7	3870	8426	28	15	80,1	48,5	1780	5509
62	369	56	30	161	98,7	3913	8386	28	15	79,7	48,5	1798	5437
64	368	56	30	161	98,7	3958	8348	28	15	79,3	48,5	1817	5368
66	367	56	30	160	98,7	4003	8314	28	15	78,9	48,5	1836	5304
68	366	56	30	159	98,7	4049	8282	28	15	78,4	48,5	1856	5245
70	365	56	30	158	98,7	4096	8253	28	15	78,0	48,5	1876	5188
72	364	56	30	157	98,7	4144	8226	28	15	77,6	48,5	1896	5136
73	364	56	30	157	98,7	4168	8214	28	15	77,4	48,5	1907	5111
74	363	56	30	156	98,7	4192	8202	28	15	77,1	48,5	1917	5086
76	362	56	30	155	98,7	4241	8180	28	15	76,7	48,5	1938	5040
78	361	56	30	155	98,7	4292	8160	28	15	76,3	48,5	1960	4997
80	360	56	30	154	98,7	4343	8143	28	15	75,9	48,5	1982	4956
82	359	56	30	153	98,7	4395	8127	28	15	75,5	48,5	2005	4918
84	358	56	30	152	98,7	4447	8113	28	15	75,0	48,5	2028	4882
86	357	56	30	151	98,7	4501	8101	28	15	74,6	48,5	2052	4849
88	356	56	30	150	98,7	4555	8091	28	15	74,2	48,5	2075	4818
90	355	56	30	150	98,7	4610	8083	28	15	73,8	48,5	2100	4789
92	354	56	30	149	98,7	4666	8076	28	15	73,4	48,5	2125	4762
94	353	56	30	148	98,7	4723	8071	28	15	72,9	48,5	2150	4737
96	352	56	30	147	98,7	4781	8068	28	15	72,5	48,5	2175	4713
98	351	56	30	146	98,7	4839	8065	28	15	72,1	48,5	2201	4692
100	350	56	30	145	98,7	4899	8065	28	15	71,7	48,5	2228	4671
102	349	56	30	145	98,7	4959	8065	28	15	71,3	48,5	2255	4653
104	348	56	30	144	98,7	5020	8067	28	15	70,9	48,5	2282	4636
106	347	56	30	143	98,7	5081	8071	28	15	70,4	48,5	2310	4620
108	346	56	30	142	98,7	5144	8075	28	15	70,0	48,5	2338	4606
110	345	56	30	141	98,7	5208	8081	28	15	69,6	48,5	2367	4592
112	344	56	30	140	98,7	5272	8088	28	15	69,2	48,5	2396	4580
114	343	56	30	140	98,7	5337	8095	28	15	68,8	48,5	2425	4570
116	342	56	30	139	98,7	5403	8104	28	15	68,4	48,5	2455	4560
118	341	56	30	138	98,7	5470	8114	28	15	68,0	48,5	2486	4551
120	340	56	30	137	98,7	5537	8125	28	15	67,6	48,5	2517	4544

B [mm]	H [mm]	full nailing						partial nailing					
		n <sub>H</sub>	n <sub>J</sub>	k <sub>H,1</sub>	k <sub>H,2</sub>	e <sub>1</sub> [mm]	e <sub>2</sub> [mm]	n <sub>H</sub>	n <sub>J</sub>	k <sub>H,1</sub>	k <sub>H,2</sub>	e <sub>1</sub> [mm]	e <sub>2</sub> [mm]
122	339	56	30	136	98,7	5606	8137	28	15	67,2	48,5	2548	4537
124	338	56	30	136	98,7	5675	8150	28	15	66,8	48,5	2579	4531
126	337	56	30	135	98,7	5745	8164	28	15	66,4	48,5	2612	4527
128	336	56	30	134	98,7	5816	8179	28	15	65,9	48,5	2644	4523
130	335	56	30	133	98,7	5888	8194	28	15	65,5	48,5	2677	4520
132	334	56	30	132	98,7	5960	8211	28	15	65,1	48,5	2710	4517
134	333	56	30	131	98,7	6034	8228	28	15	64,7	48,5	2744	4516
136	332	56	30	131	98,7	6108	8246	28	15	64,3	48,5	2778	4515
138	331	56	30	130	98,7	6183	8265	28	15	63,9	48,5	2813	4515
140	330	56	30	129	98,7	6259	8284	28	15	63,5	48,5	2848	4516
142	329	56	30	128	98,7	6336	8304	28	15	63,1	48,5	2884	4517
144	328	56	30	127	98,7	6413	8325	28	15	62,7	48,5	2920	4519
146	327	56	30	127	98,7	6492	8347	28	15	62,3	48,5	2956	4521
148	326	56	30	126	98,7	6571	8369	28	15	62,0	48,5	2993	4524
150	325	56	30	125	98,7	6651	8392	28	15	61,6	48,5	3030	4528
152	324	56	30	124	98,7	6732	8415	28	15	61,2	48,5	3068	4532
154	323	56	30	124	98,7	6814	8439	28	15	60,8	48,5	3106	4537
156	322	56	30	123	98,7	6896	8464	28	15	60,4	48,5	3145	4542
158	321	56	30	122	98,7	6980	8489	28	15	60,0	48,5	3184	4548
160	320	56	30	121	98,7	7064	8515	28	15	59,6	48,5	3223	4554

Table B32: Joist hanger Blank 620 (180 x 220): Form factors k<sub>H,1</sub> and k<sub>H,2</sub> and dimensions e<sub>1</sub> and e<sub>2</sub>; e<sub>J,0</sub> = 52 mm

B [mm]	H [mm]	full nailing						partial nailing					
		n <sub>H</sub>	n <sub>J</sub>	k <sub>H,1</sub>	k <sub>H,2</sub>	e <sub>1</sub> [mm]	e <sub>2</sub> [mm]	n <sub>H</sub>	n <sub>J</sub>	k <sub>H,1</sub>	k <sub>H,2</sub>	e <sub>1</sub> [mm]	e <sub>2</sub> [mm]
51	285	36	20	91,4	40,4	2138	3160	18	10	45,0	19,6	916	1955
60	280	36	20	88,7	40,4	2328	3191	18	10	43,7	19,6	997	1899
62	279	36	20	88,1	40,4	2372	3200	18	10	43,4	19,6	1016	1890
64	278	36	20	87,5	40,4	2417	3211	18	10	43,1	19,6	1036	1883
66	277	36	20	86,9	40,4	2464	3222	18	10	42,8	19,6	1056	1877
68	276	36	20	86,4	40,4	2511	3233	18	10	42,5	19,6	1076	1871
70	275	36	20	85,8	40,4	2558	3246	18	10	42,2	19,6	1097	1867
72	274	36	20	85,2	40,4	2607	3259	18	10	41,9	19,6	1118	1864
73	274	36	20	84,9	40,4	2632	3266	18	10	41,8	19,6	1129	1863
74	273	36	20	84,6	40,4	2657	3273	18	10	41,6	19,6	1140	1862
76	272	36	20	84,0	40,4	2707	3287	18	10	41,4	19,6	1163	1860
78	271	36	20	83,4	40,4	2758	3302	18	10	41,1	19,6	1185	1859
80	270	36	20	82,8	40,4	2810	3318	18	10	40,8	19,6	1208	1859
82	269	36	20	82,3	40,4	2863	3334	18	10	40,5	19,6	1232	1860
84	268	36	20	81,7	40,4	2917	3351	18	10	40,2	19,6	1256	1861
86	267	36	20	81,1	40,4	2972	3368	18	10	39,9	19,6	1281	1863
88	266	36	20	80,5	40,4	3027	3386	18	10	39,6	19,6	1306	1865
90	265	36	20	79,9	40,4	3084	3404	18	10	39,3	19,6	1331	1868
92	264	36	20	79,4	40,4	3141	3423	18	10	39,0	19,6	1357	1872
94	263	36	20	78,8	40,4	3199	3442	18	10	38,7	19,6	1383	1876
96	262	36	20	78,2	40,4	3258	3461	18	10	38,5	19,6	1410	1880
98	261	36	20	77,6	40,4	3317	3481	18	10	38,2	19,6	1437	1885
100	260	36	20	77,1	40,4	3378	3502	18	10	37,9	19,6	1465	1890
102	259	36	20	76,5	40,4	3439	3522	18	10	37,6	19,6	1493	1896
104	258	36	20	75,9	40,4	3502	3543	18	10	37,3	19,6	1522	1902
106	257	36	20	75,4	40,4	3565	3565	18	10	37,0	19,6	1551	1908
108	256	36	20	74,8	40,4	3629	3586	18	10	36,7	19,6	1580	1915

B [mm]	H [mm]	full nailing						partial nailing					
		n <sub>H</sub>	n <sub>J</sub>	k <sub>H,1</sub>	k <sub>H,2</sub>	e <sub>1</sub> [mm]	e <sub>2</sub> [mm]	n <sub>H</sub>	n <sub>J</sub>	k <sub>H,1</sub>	k <sub>H,2</sub>	e <sub>1</sub> [mm]	e <sub>2</sub> [mm]
110	255	36	20	74,2	40,4	3693	3609	18	10	36,4	19,6	1610	1922
112	254	36	20	73,6	40,4	3759	3631	18	10	36,2	19,6	1640	1930
114	253	36	20	73,1	40,4	3826	3654	18	10	35,9	19,6	1671	1938
116	252	36	20	72,5	40,4	3893	3677	18	10	35,6	19,6	1703	1946
118	251	36	20	72,0	40,4	3961	3700	18	10	35,3	19,6	1734	1954
120	250	36	20	71,4	40,4	4030	3724	18	10	35,0	19,6	1766	1963
122	249	36	20	70,8	40,4	4100	3747	18	10	34,8	19,6	1799	1972
124	248	36	20	70,3	40,4	4171	3771	18	10	34,5	19,6	1832	1981
126	247	36	20	69,7	40,4	4242	3796	18	10	34,2	19,6	1866	1990
128	246	36	20	69,1	40,4	4315	3820	18	10	33,9	19,6	1900	2000
130	245	36	20	68,6	40,4	4388	3845	18	10	33,6	19,6	1934	2009
132	244	36	20	68,0	40,4	4462	3870	18	10	33,4	19,6	1969	2019
134	243	36	20	67,5	40,4	4537	3896	18	10	33,1	19,6	2004	2030
136	242	36	20	66,9	40,4	4613	3921	18	10	32,8	19,6	2040	2040
138	241	36	20	66,4	40,4	4690	3947	18	10	32,5	19,6	2076	2051
140	240	36	20	65,8	40,4	4767	3973	18	10	32,3	19,6	2113	2061
142	239	36	20	65,3	40,4	4845	3999	18	10	32,0	19,6	2150	2072
144	238	36	20	64,7	40,4	4925	4025	18	10	31,7	19,6	2188	2083
146	237	36	20	64,2	40,4	5005	4051	18	10	31,4	19,6	2226	2095
148	236	36	20	63,6	40,4	5086	4078	18	10	31,2	19,6	2264	2106
150	235	36	20	63,1	40,4	5167	4105	18	10	30,9	19,6	2303	2118
152	234	36	20	62,5	40,4	5250	4132	18	10	30,6	19,6	2342	2129
154	233	36	20	62,0	40,4	5333	4159	18	10	30,3	19,6	2382	2141
156	232	36	20	61,5	40,4	5418	4186	18	10	30,1	19,6	2423	2153
158	231	36	20	60,9	40,4	5503	4214	18	10	29,8	19,6	2463	2165
160	230	36	20	60,4	40,4	5589	4241	18	10	29,5	19,6	2504	2178
162	229	36	20	59,8	40,4	5676	4269	18	10	29,3	19,6	2546	2190
164	228	36	20	59,3	40,4	5763	4297	18	10	29,0	19,6	2588	2203
166	227	36	20	58,8	40,4	5852	4325	18	10	28,7	19,6	2631	2215
168	226	36	20	58,3	40,4	5941	4353	18	10	28,5	19,6	2674	2228
170	225	36	20	57,7	40,4	6031	4382	18	10	28,2	19,6	2717	2241
172	224	36	20	57,2	40,4	6122	4410	18	10	27,9	19,6	2761	2254
174	223	36	20	56,7	40,4	6214	4439	18	10	27,7	19,6	2805	2267
176	222	36	20	56,1	40,4	6307	4468	18	10	27,4	19,6	2850	2280
178	221	36	20	55,6	40,4	6401	4496	18	10	27,2	19,6	2895	2293
180	220	36	20	55,1	40,4	6495	4525	18	10	26,9	19,6	2941	2307

Table B33: Joist hanger Blank 660 (180 x 240): Form factors k<sub>H,1</sub> and k<sub>H,2</sub> and dimensions e<sub>1</sub> and e<sub>2</sub>; e<sub>J,0</sub> = 52 mm

B [mm]	H [mm]	full nailing						partial nailing					
		n <sub>H</sub>	n <sub>J</sub>	k <sub>H,1</sub>	k <sub>H,2</sub>	e <sub>1</sub> [mm]	e <sub>2</sub> [mm]	n <sub>H</sub>	n <sub>J</sub>	k <sub>H,1</sub>	k <sub>H,2</sub>	e <sub>1</sub> [mm]	e <sub>2</sub> [mm]
51	305	40	22	106	50,0	2392	3952	20	11	52,3	24,4	1046	2510
60	300	40	22	103	50,0	2581	3954	20	11	50,9	24,4	1125	2411
62	299	40	22	103	50,0	2625	3958	20	11	50,5	24,4	1144	2395
64	298	40	22	102	50,0	2670	3963	20	11	50,2	24,4	1164	2380
66	297	40	22	101	50,0	2716	3969	20	11	49,9	24,4	1183	2367
68	296	40	22	101	50,0	2763	3976	20	11	49,6	24,4	1204	2355
70	295	40	22	99,9	50,0	2810	3984	20	11	49,2	24,4	1224	2344
72	294	40	22	99,3	50,0	2859	3994	20	11	48,9	24,4	1245	2335
73	294	40	22	99,0	50,0	2883	3998	20	11	48,8	24,4	1256	2331
74	293	40	22	98,6	50,0	2908	4003	20	11	48,6	24,4	1267	2327
76	292	40	22	98,0	50,0	2958	4014	20	11	48,3	24,4	1289	2320

B [mm]	H [mm]	full nailing						partial nailing					
		n <sub>H</sub>	n <sub>J</sub>	k <sub>H,1</sub>	k <sub>H,2</sub>	e <sub>1</sub> [mm]	e <sub>2</sub> [mm]	n <sub>H</sub>	n <sub>J</sub>	k <sub>H,1</sub>	k <sub>H,2</sub>	e <sub>1</sub> [mm]	e <sub>2</sub> [mm]
78	291	40	22	97,4	50,0	3009	4026	20	11	48,0	24,4	1311	2314
80	290	40	22	96,7	50,0	3061	4038	20	11	47,6	24,4	1334	2309
82	289	40	22	96,1	50,0	3113	4052	20	11	47,3	24,4	1358	2305
84	288	40	22	95,4	50,0	3167	4065	20	11	47,0	24,4	1381	2302
86	287	40	22	94,8	50,0	3221	4080	20	11	46,7	24,4	1406	2300
88	286	40	22	94,2	50,0	3276	4095	20	11	46,4	24,4	1430	2299
90	285	40	22	93,5	50,0	3332	4111	20	11	46,0	24,4	1455	2298
92	284	40	22	92,9	50,0	3389	4128	20	11	45,7	24,4	1481	2298
94	283	40	22	92,3	50,0	3447	4145	20	11	45,4	24,4	1507	2299
96	282	40	22	91,6	50,0	3505	4163	20	11	45,1	24,4	1533	2300
98	281	40	22	91,0	50,0	3565	4181	20	11	44,8	24,4	1560	2302
100	280	40	22	90,4	50,0	3625	4200	20	11	44,5	24,4	1588	2305
102	279	40	22	89,8	50,0	3686	4219	20	11	44,1	24,4	1615	2308
104	278	40	22	89,1	50,0	3748	4239	20	11	43,8	24,4	1644	2311
106	277	40	22	88,5	50,0	3811	4259	20	11	43,5	24,4	1672	2315
108	276	40	22	87,9	50,0	3874	4280	20	11	43,2	24,4	1701	2320
110	275	40	22	87,3	50,0	3939	4301	20	11	42,9	24,4	1731	2325
112	274	40	22	86,6	50,0	4004	4322	20	11	42,6	24,4	1761	2331
114	273	40	22	86,0	50,0	4070	4344	20	11	42,3	24,4	1791	2337
116	272	40	22	85,4	50,0	4137	4367	20	11	42,0	24,4	1822	2343
118	271	40	22	84,8	50,0	4205	4389	20	11	41,7	24,4	1854	2350
120	270	40	22	84,2	50,0	4273	4413	20	11	41,3	24,4	1885	2357
122	269	40	22	83,5	50,0	4343	4436	20	11	41,0	24,4	1918	2364
124	268	40	22	82,9	50,0	4413	4460	20	11	40,7	24,4	1950	2372
126	267	40	22	82,3	50,0	4484	4484	20	11	40,4	24,4	1983	2380
128	266	40	22	81,7	50,0	4556	4509	20	11	40,1	24,4	2017	2388
130	265	40	22	81,1	50,0	4629	4534	20	11	39,8	24,4	2051	2397
132	264	40	22	80,5	50,0	4703	4559	20	11	39,5	24,4	2085	2406
134	263	40	22	79,9	50,0	4777	4584	20	11	39,2	24,4	2120	2415
136	262	40	22	79,3	50,0	4853	4610	20	11	38,9	24,4	2156	2425
138	261	40	22	78,6	50,0	4929	4636	20	11	38,6	24,4	2191	2435
140	260	40	22	78,0	50,0	5006	4662	20	11	38,3	24,4	2228	2445
142	259	40	22	77,4	50,0	5084	4689	20	11	38,0	24,4	2264	2455
144	258	40	22	76,8	50,0	5163	4716	20	11	37,7	24,4	2301	2466
146	257	40	22	76,2	50,0	5242	4743	20	11	37,4	24,4	2339	2476
148	256	40	22	75,6	50,0	5323	4770	20	11	37,1	24,4	2377	2487
150	255	40	22	75,0	50,0	5404	4798	20	11	36,8	24,4	2415	2499
152	254	40	22	74,4	50,0	5486	4826	20	11	36,5	24,4	2454	2510
154	253	40	22	73,8	50,0	5569	4854	20	11	36,2	24,4	2494	2522
156	252	40	22	73,3	50,0	5653	4882	20	11	35,9	24,4	2533	2533
158	251	40	22	72,7	50,0	5737	4910	20	11	35,6	24,4	2574	2545
160	250	40	22	72,1	50,0	5823	4939	20	11	35,3	24,4	2614	2557
162	249	40	22	71,5	50,0	5909	4968	20	11	35,0	24,4	2655	2570
164	248	40	22	70,9	50,0	5996	4997	20	11	34,7	24,4	2697	2582
166	247	40	22	70,3	50,0	6084	5026	20	11	34,4	24,4	2739	2595
168	246	40	22	69,7	50,0	6173	5056	20	11	34,1	24,4	2781	2608
170	245	40	22	69,1	50,0	6263	5085	20	11	33,9	24,4	2824	2620
172	244	40	22	68,6	50,0	6353	5115	20	11	33,6	24,4	2868	2633
174	243	40	22	68,0	50,0	6445	5145	20	11	33,3	24,4	2911	2647
176	242	40	22	67,4	50,0	6537	5175	20	11	33,0	24,4	2956	2660
178	241	40	22	66,8	50,0	6630	5205	20	11	32,7	24,4	3000	2673
180	240	40	22	66,3	50,0	6724	5236	20	11	32,4	24,4	3045	2687

Table B34: Joist hanger Blank 700 (180 x 260): Form factors  $k_{H,1}$  and  $k_{H,2}$  and dimensions  $e_1$  and  $e_2$ ;  $e_{J,0} = 52$  mm

B [mm]	H [mm]	full nailing						partial nailing					
		$n_H$	$n_J$	$k_{H,1}$	$k_{H,2}$	$e_1$ [mm]	$e_2$ [mm]	$n_H$	$n_J$	$k_{H,1}$	$k_{H,2}$	$e_1$ [mm]	$e_2$ [mm]
51	325	44	24	122	60,6	2674	4883	22	12	60,1	29,6	1189	3172
60	320	44	24	119	60,6	2862	4846	22	12	58,5	29,6	1268	3019
62	319	44	24	118	60,6	2906	4843	22	12	58,1	29,6	1287	2993
64	318	44	24	117	60,6	2951	4841	22	12	57,8	29,6	1306	2968
66	317	44	24	116	60,6	2996	4840	22	12	57,4	29,6	1326	2946
68	316	44	24	116	60,6	3043	4841	22	12	57,1	29,6	1346	2925
70	315	44	24	115	60,6	3090	4843	22	12	56,7	29,6	1366	2906
72	314	44	24	114	60,6	3138	4846	22	12	56,4	29,6	1387	2889
73	314	44	24	114	60,6	3163	4848	22	12	56,2	29,6	1397	2881
74	313	44	24	114	60,6	3187	4850	22	12	56,0	29,6	1408	2874
76	312	44	24	113	60,6	3237	4856	22	12	55,7	29,6	1430	2860
78	311	44	24	112	60,6	3288	4862	22	12	55,3	29,6	1452	2847
80	310	44	24	112	60,6	3339	4870	22	12	55,0	29,6	1475	2836
82	309	44	24	111	60,6	3392	4879	22	12	54,7	29,6	1498	2826
84	308	44	24	110	60,6	3445	4888	22	12	54,3	29,6	1522	2818
86	307	44	24	110	60,6	3499	4899	22	12	54,0	29,6	1546	2810
88	306	44	24	109	60,6	3554	4910	22	12	53,6	29,6	1570	2803
90	305	44	24	108	60,6	3610	4922	22	12	53,3	29,6	1595	2798
92	304	44	24	107	60,6	3666	4935	22	12	52,9	29,6	1620	2793
94	303	44	24	107	60,6	3724	4949	22	12	52,6	29,6	1646	2790
96	302	44	24	106	60,6	3782	4964	22	12	52,2	29,6	1672	2787
98	301	44	24	105	60,6	3841	4979	22	12	51,9	29,6	1699	2785
100	300	44	24	105	60,6	3901	4995	22	12	51,6	29,6	1726	2783
102	299	44	24	104	60,6	3962	5012	22	12	51,2	29,6	1753	2783
104	298	44	24	103	60,6	4023	5029	22	12	50,9	29,6	1781	2783
106	297	44	24	103	60,6	4086	5047	22	12	50,5	29,6	1810	2784
108	296	44	24	102	60,6	4149	5066	22	12	50,2	29,6	1838	2785
110	295	44	24	101	60,6	4213	5085	22	12	49,9	29,6	1868	2787
112	294	44	24	101	60,6	4278	5105	22	12	49,5	29,6	1897	2790
114	293	44	24	100	60,6	4344	5125	22	12	49,2	29,6	1927	2793
116	292	44	24	99,3	60,6	4410	5146	22	12	48,8	29,6	1958	2797
118	291	44	24	98,6	60,6	4478	5167	22	12	48,5	29,6	1989	2801
120	290	44	24	97,9	60,6	4546	5189	22	12	48,2	29,6	2020	2806
122	289	44	24	97,3	60,6	4615	5211	22	12	47,8	29,6	2052	2811
124	288	44	24	96,6	60,6	4685	5234	22	12	47,5	29,6	2085	2817
126	287	44	24	95,9	60,6	4756	5257	22	12	47,2	29,6	2118	2823
128	286	44	24	95,3	60,6	4828	5280	22	12	46,8	29,6	2151	2830
130	285	44	24	94,6	60,6	4900	5304	22	12	46,5	29,6	2184	2837
132	284	44	24	93,9	60,6	4974	5329	22	12	46,2	29,6	2218	2844
134	283	44	24	93,3	60,6	5048	5354	22	12	45,8	29,6	2253	2852
136	282	44	24	92,6	60,6	5123	5379	22	12	45,5	29,6	2288	2860
138	281	44	24	91,9	60,6	5199	5405	22	12	45,2	29,6	2323	2868
140	280	44	24	91,3	60,6	5275	5431	22	12	44,8	29,6	2359	2877
142	279	44	24	90,6	60,6	5353	5457	22	12	44,5	29,6	2396	2886
144	278	44	24	90,0	60,6	5431	5484	22	12	44,2	29,6	2432	2896
146	277	44	24	89,3	60,6	5510	5510	22	12	43,9	29,6	2470	2905
148	276	44	24	88,7	60,6	5591	5538	22	12	43,5	29,6	2507	2915
150	275	44	24	88,0	60,6	5671	5565	22	12	43,2	29,6	2545	2925
152	274	44	24	87,4	60,6	5753	5593	22	12	42,9	29,6	2584	2936
154	273	44	24	86,7	60,6	5836	5622	22	12	42,6	29,6	2623	2947



B [mm]	H [mm]	full nailing						partial nailing					
		n <sub>H</sub>	n <sub>J</sub>	k <sub>H,1</sub>	k <sub>H,2</sub>	e <sub>1</sub> [mm]	e <sub>2</sub> [mm]	n <sub>H</sub>	n <sub>J</sub>	k <sub>H,1</sub>	k <sub>H,2</sub>	e <sub>1</sub> [mm]	e <sub>2</sub> [mm]
156	272	44	24	86,1	60,6	5919	5650	22	12	42,2	29,6	2662	2958
158	271	44	24	85,4	60,6	6003	5679	22	12	41,9	29,6	2702	2969
160	270	44	24	84,8	60,6	6088	5708	22	12	41,6	29,6	2742	2981
162	269	44	24	84,1	60,6	6174	5737	22	12	41,3	29,6	2783	2992
164	268	44	24	83,5	60,6	6261	5767	22	12	41,0	29,6	2824	3004
166	267	44	24	82,9	60,6	6349	5797	22	12	40,6	29,6	2866	3016
168	266	44	24	82,2	60,6	6437	5827	22	12	40,3	29,6	2908	3029
170	265	44	24	81,6	60,6	6526	5857	22	12	40,0	29,6	2950	3041
172	264	44	24	81,0	60,6	6616	5887	22	12	39,7	29,6	2993	3054
174	263	44	24	80,3	60,6	6707	5918	22	12	39,4	29,6	3036	3067
176	262	44	24	79,7	60,6	6799	5949	22	12	39,1	29,6	3080	3080
178	261	44	24	79,1	60,6	6892	5980	22	12	38,8	29,6	3124	3093
180	260	44	24	78,4	60,6	6985	6012	22	12	38,4	29,6	3169	3107

Table B35: Joist hanger Blank 740 (180 x 280): Form factors k<sub>H,1</sub> and k<sub>H,2</sub> and dimensions e<sub>1</sub> and e<sub>2</sub>; e<sub>J,0</sub> = 52 mm

B [mm]	H [mm]	full nailing						partial nailing					
		n <sub>H</sub>	n <sub>J</sub>	k <sub>H,1</sub>	k <sub>H,2</sub>	e <sub>1</sub> [mm]	e <sub>2</sub> [mm]	n <sub>H</sub>	n <sub>J</sub>	k <sub>H,1</sub>	k <sub>H,2</sub>	e <sub>1</sub> [mm]	e <sub>2</sub> [mm]
51	345	48	26	138	72,3	2983	5967	24	13	68,4	35,4	1347	3951
60	340	48	26	135	72,3	3170	5881	24	13	66,7	35,4	1425	3732
62	339	48	26	134	72,3	3214	5867	24	13	66,3	35,4	1443	3692
64	338	48	26	134	72,3	3259	5856	24	13	65,9	35,4	1462	3656
66	337	48	26	133	72,3	3304	5846	24	13	65,5	35,4	1482	3622
68	336	48	26	132	72,3	3351	5838	24	13	65,1	35,4	1502	3591
70	335	48	26	131	72,3	3398	5832	24	13	64,8	35,4	1522	3562
72	334	48	26	131	72,3	3446	5828	24	13	64,4	35,4	1543	3535
73	334	48	26	130	72,3	3470	5826	24	13	64,2	35,4	1553	3523
74	333	48	26	130	72,3	3495	5824	24	13	64,0	35,4	1564	3511
76	332	48	26	129	72,3	3544	5823	24	13	63,6	35,4	1585	3488
78	331	48	26	128	72,3	3595	5823	24	13	63,2	35,4	1607	3467
80	330	48	26	127	72,3	3646	5824	24	13	62,9	35,4	1630	3448
82	329	48	26	127	72,3	3698	5826	24	13	62,5	35,4	1653	3430
84	328	48	26	126	72,3	3751	5830	24	13	62,1	35,4	1676	3415
86	327	48	26	125	72,3	3805	5835	24	13	61,7	35,4	1700	3400
88	326	48	26	125	72,3	3860	5841	24	13	61,4	35,4	1724	3387
90	325	48	26	124	72,3	3915	5848	24	13	61,0	35,4	1749	3375
92	324	48	26	123	72,3	3972	5856	24	13	60,6	35,4	1774	3364
94	323	48	26	122	72,3	4029	5865	24	13	60,3	35,4	1799	3355
96	322	48	26	122	72,3	4087	5875	24	13	59,9	35,4	1825	3347
98	321	48	26	121	72,3	4146	5886	24	13	59,5	35,4	1852	3339
100	320	48	26	120	72,3	4205	5898	24	13	59,2	35,4	1879	3333
102	319	48	26	119	72,3	4266	5911	24	13	58,8	35,4	1906	3328
104	318	48	26	119	72,3	4327	5924	24	13	58,4	35,4	1934	3324
106	317	48	26	118	72,3	4390	5939	24	13	58,0	35,4	1962	3320
108	316	48	26	117	72,3	4453	5954	24	13	57,7	35,4	1990	3317
110	315	48	26	116	72,3	4516	5970	24	13	57,3	35,4	2019	3315
112	314	48	26	116	72,3	4581	5987	24	13	56,9	35,4	2049	3314
114	313	48	26	115	72,3	4647	6004	24	13	56,6	35,4	2079	3314
116	312	48	26	114	72,3	4713	6022	24	13	56,2	35,4	2109	3314
118	311	48	26	113	72,3	4780	6041	24	13	55,9	35,4	2140	3315
120	310	48	26	113	72,3	4848	6060	24	13	55,5	35,4	2171	3317
122	309	48	26	112	72,3	4917	6080	24	13	55,1	35,4	2203	3319

B [mm]	H [mm]	full nailing						partial nailing					
		n <sub>H</sub>	n <sub>J</sub>	k <sub>H,1</sub>	k <sub>H,2</sub>	e <sub>1</sub> [mm]	e <sub>2</sub> [mm]	n <sub>H</sub>	n <sub>J</sub>	k <sub>H,1</sub>	k <sub>H,2</sub>	e <sub>1</sub> [mm]	e <sub>2</sub> [mm]
124	308	48	26	111	72,3	4987	6101	24	13	54,8	35,4	2235	3322
126	307	48	26	111	72,3	5057	6122	24	13	54,4	35,4	2267	3325
128	306	48	26	110	72,3	5129	6144	24	13	54,1	35,4	2300	3329
130	305	48	26	109	72,3	5201	6166	24	13	53,7	35,4	2334	3334
132	304	48	26	108	72,3	5274	6189	24	13	53,3	35,4	2367	3339
134	303	48	26	108	72,3	5348	6212	24	13	53,0	35,4	2402	3344
136	302	48	26	107	72,3	5423	6236	24	13	52,6	35,4	2436	3350
138	301	48	26	106	72,3	5498	6260	24	13	52,3	35,4	2471	3356
140	300	48	26	106	72,3	5575	6285	24	13	51,9	35,4	2507	3363
142	299	48	26	105	72,3	5652	6310	24	13	51,6	35,4	2543	3370
144	298	48	26	104	72,3	5730	6336	24	13	51,2	35,4	2579	3378
146	297	48	26	103	72,3	5809	6362	24	13	50,8	35,4	2616	3386
148	296	48	26	103	72,3	5888	6388	24	13	50,5	35,4	2654	3394
150	295	48	26	102	72,3	5969	6415	24	13	50,1	35,4	2691	3403
152	294	48	26	101	72,3	6050	6443	24	13	49,8	35,4	2730	3412
154	293	48	26	101	72,3	6133	6470	24	13	49,4	35,4	2768	3421
156	292	48	26	99,9	72,3	6216	6498	24	13	49,1	35,4	2807	3431
158	291	48	26	99,2	72,3	6300	6527	24	13	48,7	35,4	2847	3441
160	290	48	26	98,5	72,3	6384	6555	24	13	48,4	35,4	2887	3451
162	289	48	26	97,8	72,3	6470	6584	24	13	48,1	35,4	2927	3462
164	288	48	26	97,1	72,3	6556	6614	24	13	47,7	35,4	2968	3473
166	287	48	26	96,4	72,3	6643	6643	24	13	47,4	35,4	3009	3484
168	286	48	26	95,8	72,3	6732	6674	24	13	47,0	35,4	3051	3496
170	285	48	26	95,1	72,3	6820	6704	24	13	46,7	35,4	3093	3507
172	284	48	26	94,4	72,3	6910	6735	24	13	46,3	35,4	3135	3519
174	283	48	26	93,7	72,3	7001	6765	24	13	46,0	35,4	3178	3532
176	282	48	26	93,0	72,3	7092	6797	24	13	45,7	35,4	3222	3544
178	281	48	26	92,3	72,3	7184	6828	24	13	45,3	35,4	3266	3557
180	280	48	26	91,7	72,3	7277	6860	24	13	45,0	35,4	3310	3570

Table B36: Joist hanger Blank 780 (180 x 300): Form factors k<sub>H,1</sub> and k<sub>H,2</sub> and dimensions e<sub>1</sub> and e<sub>2</sub>; e<sub>J,0</sub> = 52 mm

B [mm]	H [mm]	full nailing						partial nailing					
		n <sub>H</sub>	n <sub>J</sub>	k <sub>H,1</sub>	k <sub>H,2</sub>	e <sub>1</sub> [mm]	e <sub>2</sub> [mm]	n <sub>H</sub>	n <sub>J</sub>	k <sub>H,1</sub>	k <sub>H,2</sub>	e <sub>1</sub> [mm]	e <sub>2</sub> [mm]
51	365	52	28	156	85,0	3320	7218	26	14	77,1	41,7	1518	4858
60	360	52	28	153	85,0	3506	7069	26	14	75,3	41,7	1596	4559
62	359	52	28	152	85,0	3550	7044	26	14	74,9	41,7	1614	4504
64	358	52	28	151	85,0	3595	7021	26	14	74,5	41,7	1633	4453
66	357	52	28	150	85,0	3640	7000	26	14	74,1	41,7	1652	4406
68	356	52	28	149	85,0	3686	6981	26	14	73,7	41,7	1672	4361
70	355	52	28	148	85,0	3733	6965	26	14	73,3	41,7	1692	4320
72	354	52	28	148	85,0	3781	6950	26	14	72,9	41,7	1713	4281
73	354	52	28	147	85,0	3805	6944	26	14	72,7	41,7	1723	4263
74	353	52	28	147	85,0	3830	6938	26	14	72,5	41,7	1734	4245
76	352	52	28	146	85,0	3879	6927	26	14	72,1	41,7	1755	4212
78	351	52	28	145	85,0	3930	6918	26	14	71,7	41,7	1777	4181
80	350	52	28	144	85,0	3981	6911	26	14	71,3	41,7	1799	4152
82	349	52	28	144	85,0	4033	6905	26	14	70,8	41,7	1822	4125
84	348	52	28	143	85,0	4086	6901	26	14	70,4	41,7	1845	4100
86	347	52	28	142	85,0	4139	6899	26	14	70,0	41,7	1869	4077
88	346	52	28	141	85,0	4194	6898	26	14	69,6	41,7	1893	4056
90	345	52	28	140	85,0	4249	6898	26	14	69,2	41,7	1917	4036

B [mm]	H [mm]	full nailing						partial nailing					
		n <sub>H</sub>	n <sub>J</sub>	k <sub>H,1</sub>	k <sub>H,2</sub>	e <sub>1</sub> [mm]	e <sub>2</sub> [mm]	n <sub>H</sub>	n <sub>J</sub>	k <sub>H,1</sub>	k <sub>H,2</sub>	e <sub>1</sub> [mm]	e <sub>2</sub> [mm]
92	344	52	28	140	85,0	4305	6899	26	14	68,8	41,7	1942	4018
94	343	52	28	139	85,0	4362	6902	26	14	68,4	41,7	1968	4002
96	342	52	28	138	85,0	4420	6906	26	14	68,1	41,7	1993	3987
98	341	52	28	137	85,0	4479	6912	26	14	67,7	41,7	2020	3973
100	340	52	28	136	85,0	4538	6918	26	14	67,3	41,7	2046	3960
102	339	52	28	136	85,0	4598	6925	26	14	66,9	41,7	2073	3949
104	338	52	28	135	85,0	4660	6934	26	14	66,5	41,7	2101	3939
106	337	52	28	134	85,0	4722	6944	26	14	66,1	41,7	2129	3930
108	336	52	28	133	85,0	4784	6954	26	14	65,7	41,7	2157	3922
110	335	52	28	132	85,0	4848	6966	26	14	65,3	41,7	2186	3915
112	334	52	28	132	85,0	4913	6978	26	14	64,9	41,7	2215	3909
114	333	52	28	131	85,0	4978	6991	26	14	64,5	41,7	2245	3904
116	332	52	28	130	85,0	5044	7006	26	14	64,1	41,7	2275	3900
118	331	52	28	129	85,0	5111	7021	26	14	63,7	41,7	2306	3897
120	330	52	28	129	85,0	5179	7036	26	14	63,3	41,7	2337	3894
122	329	52	28	128	85,0	5247	7053	26	14	62,9	41,7	2368	3893
124	328	52	28	127	85,0	5317	7070	26	14	62,6	41,7	2400	3892
126	327	52	28	126	85,0	5387	7088	26	14	62,2	41,7	2432	3891
128	326	52	28	125	85,0	5458	7107	26	14	61,8	41,7	2465	3892
130	325	52	28	125	85,0	5530	7127	26	14	61,4	41,7	2498	3893
132	324	52	28	124	85,0	5603	7147	26	14	61,0	41,7	2532	3895
134	323	52	28	123	85,0	5677	7168	26	14	60,6	41,7	2566	3897
136	322	52	28	122	85,0	5751	7189	26	14	60,2	41,7	2600	3900
138	321	52	28	122	85,0	5826	7211	26	14	59,9	41,7	2635	3904
140	320	52	28	121	85,0	5903	7234	26	14	59,5	41,7	2670	3908
142	319	52	28	120	85,0	5980	7257	26	14	59,1	41,7	2706	3912
144	318	52	28	119	85,0	6057	7281	26	14	58,7	41,7	2742	3917
146	317	52	28	119	85,0	6136	7305	26	14	58,3	41,7	2779	3923
148	316	52	28	118	85,0	6215	7330	26	14	58,0	41,7	2816	3929
150	315	52	28	117	85,0	6296	7355	26	14	57,6	41,7	2853	3936
152	314	52	28	116	85,0	6377	7381	26	14	57,2	41,7	2891	3943
154	313	52	28	116	85,0	6459	7407	26	14	56,8	41,7	2930	3950
156	312	52	28	115	85,0	6542	7434	26	14	56,5	41,7	2968	3958
158	311	52	28	114	85,0	6625	7461	26	14	56,1	41,7	3008	3966
160	310	52	28	113	85,0	6710	7488	26	14	55,7	41,7	3047	3975
162	309	52	28	113	85,0	6795	7517	26	14	55,3	41,7	3087	3984
164	308	52	28	112	85,0	6881	7545	26	14	55,0	41,7	3128	3993
166	307	52	28	111	85,0	6968	7574	26	14	54,6	41,7	3169	4003
168	306	52	28	110	85,0	7056	7603	26	14	54,2	41,7	3210	4013
170	305	52	28	110	85,0	7144	7633	26	14	53,9	41,7	3252	4023
172	304	52	28	109	85,0	7234	7663	26	14	53,5	41,7	3294	4034
174	303	52	28	108	85,0	7324	7693	26	14	53,1	41,7	3337	4045
176	302	52	28	107	85,0	7415	7724	26	14	52,8	41,7	3380	4056
178	301	52	28	107	85,0	7507	7755	26	14	52,4	41,7	3424	4068
180	300	52	28	106	85,0	7600	7787	26	14	52,0	41,7	3468	4079

Table B37: Joist hanger Blank 820 (180 x 320): Form factors k<sub>H,1</sub> and k<sub>H,2</sub> and dimensions e<sub>1</sub> and e<sub>2</sub>; e<sub>J,0</sub> = 52 mm

B [mm]	H [mm]	full nailing						partial nailing					
		n <sub>H</sub>	n <sub>J</sub>	k <sub>H,1</sub>	k <sub>H,2</sub>	e <sub>1</sub> [mm]	e <sub>2</sub> [mm]	n <sub>H</sub>	n <sub>J</sub>	k <sub>H,1</sub>	k <sub>H,2</sub>	e <sub>1</sub> [mm]	e <sub>2</sub> [mm]
51	385	56	30	175	98,7	3684	8650	28	15	86,4	48,5	1703	5903
60	380	56	30	171	98,7	3870	8426	28	15	84,5	48,5	1780	5509

B [mm]	H [mm]	full nailing						partial nailing					
		n <sub>H</sub>	n <sub>J</sub>	k <sub>H,1</sub>	k <sub>H,2</sub>	e <sub>1</sub> [mm]	e <sub>2</sub> [mm]	n <sub>H</sub>	n <sub>J</sub>	k <sub>H,1</sub>	k <sub>H,2</sub>	e <sub>1</sub> [mm]	e <sub>2</sub> [mm]
62	379	56	30	170	98,7	3913	8386	28	15	84,0	48,5	1798	5437
64	378	56	30	169	98,7	3958	8348	28	15	83,6	48,5	1817	5368
66	377	56	30	168	98,7	4003	8314	28	15	83,2	48,5	1836	5304
68	376	56	30	167	98,7	4049	8282	28	15	82,7	48,5	1856	5245
70	375	56	30	167	98,7	4096	8253	28	15	82,3	48,5	1876	5188
72	374	56	30	166	98,7	4144	8226	28	15	81,9	48,5	1896	5136
73	374	56	30	165	98,7	4168	8214	28	15	81,6	48,5	1907	5111
74	373	56	30	165	98,7	4192	8202	28	15	81,4	48,5	1917	5086
76	372	56	30	164	98,7	4241	8180	28	15	81,0	48,5	1938	5040
78	371	56	30	163	98,7	4292	8160	28	15	80,6	48,5	1960	4997
80	370	56	30	162	98,7	4343	8143	28	15	80,1	48,5	1982	4956
82	369	56	30	161	98,7	4395	8127	28	15	79,7	48,5	2005	4918
84	368	56	30	161	98,7	4447	8113	28	15	79,3	48,5	2028	4882
86	367	56	30	160	98,7	4501	8101	28	15	78,9	48,5	2052	4849
88	366	56	30	159	98,7	4555	8091	28	15	78,4	48,5	2075	4818
90	365	56	30	158	98,7	4610	8083	28	15	78,0	48,5	2100	4789
92	364	56	30	157	98,7	4666	8076	28	15	77,6	48,5	2125	4762
94	363	56	30	156	98,7	4723	8071	28	15	77,1	48,5	2150	4737
96	362	56	30	155	98,7	4781	8068	28	15	76,7	48,5	2175	4713
98	361	56	30	155	98,7	4839	8065	28	15	76,3	48,5	2201	4692
100	360	56	30	154	98,7	4899	8065	28	15	75,9	48,5	2228	4671
102	359	56	30	153	98,7	4959	8065	28	15	75,5	48,5	2255	4653
104	358	56	30	152	98,7	5020	8067	28	15	75,0	48,5	2282	4636
106	357	56	30	151	98,7	5081	8071	28	15	74,6	48,5	2310	4620
108	356	56	30	150	98,7	5144	8075	28	15	74,2	48,5	2338	4606
110	355	56	30	150	98,7	5208	8081	28	15	73,8	48,5	2367	4592
112	354	56	30	149	98,7	5272	8088	28	15	73,4	48,5	2396	4580
114	353	56	30	148	98,7	5337	8095	28	15	72,9	48,5	2425	4570
116	352	56	30	147	98,7	5403	8104	28	15	72,5	48,5	2455	4560
118	351	56	30	146	98,7	5470	8114	28	15	72,1	48,5	2486	4551
120	350	56	30	145	98,7	5537	8125	28	15	71,7	48,5	2517	4544
122	349	56	30	145	98,7	5606	8137	28	15	71,3	48,5	2548	4537
124	348	56	30	144	98,7	5675	8150	28	15	70,9	48,5	2579	4531
126	347	56	30	143	98,7	5745	8164	28	15	70,4	48,5	2612	4527
128	346	56	30	142	98,7	5816	8179	28	15	70,0	48,5	2644	4523
130	345	56	30	141	98,7	5888	8194	28	15	69,6	48,5	2677	4520
132	344	56	30	140	98,7	5960	8211	28	15	69,2	48,5	2710	4517
134	343	56	30	140	98,7	6034	8228	28	15	68,8	48,5	2744	4516
136	342	56	30	139	98,7	6108	8246	28	15	68,4	48,5	2778	4515
138	341	56	30	138	98,7	6183	8265	28	15	68,0	48,5	2813	4515
140	340	56	30	137	98,7	6259	8284	28	15	67,6	48,5	2848	4516
142	339	56	30	136	98,7	6336	8304	28	15	67,2	48,5	2884	4517
144	338	56	30	136	98,7	6413	8325	28	15	66,8	48,5	2920	4519
146	337	56	30	135	98,7	6492	8347	28	15	66,4	48,5	2956	4521
148	336	56	30	134	98,7	6571	8369	28	15	65,9	48,5	2993	4524
150	335	56	30	133	98,7	6651	8392	28	15	65,5	48,5	3030	4528
152	334	56	30	132	98,7	6732	8415	28	15	65,1	48,5	3068	4532
154	333	56	30	131	98,7	6814	8439	28	15	64,7	48,5	3106	4537
156	332	56	30	131	98,7	6896	8464	28	15	64,3	48,5	3145	4542
158	331	56	30	130	98,7	6980	8489	28	15	63,9	48,5	3184	4548
160	330	56	30	129	98,7	7064	8515	28	15	63,5	48,5	3223	4554
162	329	56	30	128	98,7	7149	8541	28	15	63,1	48,5	3263	4561

B [mm]	H [mm]	full nailing						partial nailing					
		n <sub>H</sub>	n <sub>J</sub>	k <sub>H,1</sub>	k <sub>H,2</sub>	e <sub>1</sub> [mm]	e <sub>2</sub> [mm]	n <sub>H</sub>	n <sub>J</sub>	k <sub>H,1</sub>	k <sub>H,2</sub>	e <sub>1</sub> [mm]	e <sub>2</sub> [mm]
164	328	56	30	127	98,7	7235	8568	28	15	62,7	48,5	3303	4568
166	327	56	30	127	98,7	7321	8595	28	15	62,3	48,5	3344	4576
168	326	56	30	126	98,7	7409	8623	28	15	62,0	48,5	3385	4584
170	325	56	30	125	98,7	7497	8651	28	15	61,6	48,5	3427	4592
172	324	56	30	124	98,7	7587	8680	28	15	61,2	48,5	3469	4601
174	323	56	30	124	98,7	7677	8709	28	15	60,8	48,5	3511	4610
176	322	56	30	123	98,7	7767	8738	28	15	60,4	48,5	3554	4620
178	321	56	30	122	98,7	7859	8768	28	15	60,0	48,5	3597	4630
180	320	56	30	121	98,7	7952	8799	28	15	59,6	48,5	3641	4640

Table B38: Joist hanger Blank 640 (200 x 220): Form factors k<sub>H,1</sub> and k<sub>H,2</sub> and dimensions e<sub>1</sub> and e<sub>2</sub>; e<sub>J,0</sub> = 52 mm

B [mm]	H [mm]	full nailing						partial nailing					
		n <sub>H</sub>	n <sub>J</sub>	k <sub>H,1</sub>	k <sub>H,2</sub>	e <sub>1</sub> [mm]	e <sub>2</sub> [mm]	n <sub>H</sub>	n <sub>J</sub>	k <sub>H,1</sub>	k <sub>H,2</sub>	e <sub>1</sub> [mm]	e <sub>2</sub> [mm]
51	295	36	20	97,4	40,4	2138	3160	18	10	48,0	19,6	916	1955
60	290	36	20	94,7	40,4	2328	3191	18	10	46,7	19,6	997	1899
62	289	36	20	94,1	40,4	2372	3200	18	10	46,4	19,6	1016	1890
64	288	36	20	93,5	40,4	2417	3211	18	10	46,1	19,6	1036	1883
66	287	36	20	92,9	40,4	2464	3222	18	10	45,8	19,6	1056	1877
68	286	36	20	92,3	40,4	2511	3233	18	10	45,5	19,6	1076	1871
70	285	36	20	91,7	40,4	2558	3246	18	10	45,2	19,6	1097	1867
72	284	36	20	91,1	40,4	2607	3259	18	10	44,9	19,6	1118	1864
73	284	36	20	90,8	40,4	2632	3266	18	10	44,7	19,6	1129	1863
74	283	36	20	90,5	40,4	2657	3273	18	10	44,6	19,6	1140	1862
76	282	36	20	89,9	40,4	2707	3287	18	10	44,3	19,6	1163	1860
78	281	36	20	89,3	40,4	2758	3302	18	10	44,0	19,6	1185	1859
80	280	36	20	88,7	40,4	2810	3318	18	10	43,7	19,6	1208	1859
82	279	36	20	88,1	40,4	2863	3334	18	10	43,4	19,6	1232	1860
84	278	36	20	87,5	40,4	2917	3351	18	10	43,1	19,6	1256	1861
86	277	36	20	86,9	40,4	2972	3368	18	10	42,8	19,6	1281	1863
88	276	36	20	86,4	40,4	3027	3386	18	10	42,5	19,6	1306	1865
90	275	36	20	85,8	40,4	3084	3404	18	10	42,2	19,6	1331	1868
92	274	36	20	85,2	40,4	3141	3423	18	10	41,9	19,6	1357	1872
94	273	36	20	84,6	40,4	3199	3442	18	10	41,6	19,6	1383	1876
96	272	36	20	84,0	40,4	3258	3461	18	10	41,4	19,6	1410	1880
98	271	36	20	83,4	40,4	3317	3481	18	10	41,1	19,6	1437	1885
100	270	36	20	82,8	40,4	3378	3502	18	10	40,8	19,6	1465	1890
102	269	36	20	82,3	40,4	3439	3522	18	10	40,5	19,6	1493	1896
104	268	36	20	81,7	40,4	3502	3543	18	10	40,2	19,6	1522	1902
106	267	36	20	81,1	40,4	3565	3565	18	10	39,9	19,6	1551	1908
108	266	36	20	80,5	40,4	3629	3586	18	10	39,6	19,6	1580	1915
110	265	36	20	79,9	40,4	3693	3609	18	10	39,3	19,6	1610	1922
112	264	36	20	79,4	40,4	3759	3631	18	10	39,0	19,6	1640	1930
114	263	36	20	78,8	40,4	3826	3654	18	10	38,7	19,6	1671	1938
116	262	36	20	78,2	40,4	3893	3677	18	10	38,5	19,6	1703	1946
118	261	36	20	77,6	40,4	3961	3700	18	10	38,2	19,6	1734	1954
120	260	36	20	77,1	40,4	4030	3724	18	10	37,9	19,6	1766	1963
122	259	36	20	76,5	40,4	4100	3747	18	10	37,6	19,6	1799	1972
124	258	36	20	75,9	40,4	4171	3771	18	10	37,3	19,6	1832	1981
126	257	36	20	75,4	40,4	4242	3796	18	10	37,0	19,6	1866	1990
128	256	36	20	74,8	40,4	4315	3820	18	10	36,7	19,6	1900	2000
130	255	36	20	74,2	40,4	4388	3845	18	10	36,4	19,6	1934	2009

B [mm]	H [mm]	full nailing						partial nailing					
		n <sub>H</sub>	n <sub>J</sub>	k <sub>H,1</sub>	k <sub>H,2</sub>	e <sub>1</sub> [mm]	e <sub>2</sub> [mm]	n <sub>H</sub>	n <sub>J</sub>	k <sub>H,1</sub>	k <sub>H,2</sub>	e <sub>1</sub> [mm]	e <sub>2</sub> [mm]
132	254	36	20	73,6	40,4	4462	3870	18	10	36,2	19,6	1969	2019
134	253	36	20	73,1	40,4	4537	3896	18	10	35,9	19,6	2004	2030
136	252	36	20	72,5	40,4	4613	3921	18	10	35,6	19,6	2040	2040
138	251	36	20	72,0	40,4	4690	3947	18	10	35,3	19,6	2076	2051
140	250	36	20	71,4	40,4	4767	3973	18	10	35,0	19,6	2113	2061
142	249	36	20	70,8	40,4	4845	3999	18	10	34,8	19,6	2150	2072
144	248	36	20	70,3	40,4	4925	4025	18	10	34,5	19,6	2188	2083
146	247	36	20	69,7	40,4	5005	4051	18	10	34,2	19,6	2226	2095
148	246	36	20	69,1	40,4	5086	4078	18	10	33,9	19,6	2264	2106
150	245	36	20	68,6	40,4	5167	4105	18	10	33,6	19,6	2303	2118
152	244	36	20	68,0	40,4	5250	4132	18	10	33,4	19,6	2342	2129
154	243	36	20	67,5	40,4	5333	4159	18	10	33,1	19,6	2382	2141
156	242	36	20	66,9	40,4	5418	4186	18	10	32,8	19,6	2423	2153
158	241	36	20	66,4	40,4	5503	4214	18	10	32,5	19,6	2463	2165
160	240	36	20	65,8	40,4	5589	4241	18	10	32,3	19,6	2504	2178
162	239	36	20	65,3	40,4	5676	4269	18	10	32,0	19,6	2546	2190
164	238	36	20	64,7	40,4	5763	4297	18	10	31,7	19,6	2588	2203
166	237	36	20	64,2	40,4	5852	4325	18	10	31,4	19,6	2631	2215
168	236	36	20	63,6	40,4	5941	4353	18	10	31,2	19,6	2674	2228
170	235	36	20	63,1	40,4	6031	4382	18	10	30,9	19,6	2717	2241
172	234	36	20	62,5	40,4	6122	4410	18	10	30,6	19,6	2761	2254
174	233	36	20	62,0	40,4	6214	4439	18	10	30,3	19,6	2805	2267
176	232	36	20	61,5	40,4	6307	4468	18	10	30,1	19,6	2850	2280
178	231	36	20	60,9	40,4	6401	4496	18	10	29,8	19,6	2895	2293
180	230	36	20	60,4	40,4	6495	4525	18	10	29,5	19,6	2941	2307
182	229	36	20	59,8	40,4	6590	4554	18	10	29,3	19,6	2987	2320
184	228	36	20	59,3	40,4	6687	4584	18	10	29,0	19,6	3034	2334
186	227	36	20	58,8	40,4	6784	4613	18	10	28,7	19,6	3081	2347
188	226	36	20	58,3	40,4	6881	4642	18	10	28,5	19,6	3128	2361
190	225	36	20	57,7	40,4	6980	4672	18	10	28,2	19,6	3176	2375
192	224	36	20	57,2	40,4	7080	4701	18	10	27,9	19,6	3224	2388
194	223	36	20	56,7	40,4	7180	4731	18	10	27,7	19,6	3273	2402
196	222	36	20	56,1	40,4	7281	4761	18	10	27,4	19,6	3323	2416
198	221	36	20	55,6	40,4	7383	4791	18	10	27,2	19,6	3372	2430
200	220	36	20	55,1	40,4	7486	4821	18	10	26,9	19,6	3422	2445

Table B39: Joist hanger Blank 680 (200 x 240): Form factors k<sub>H,1</sub> and k<sub>H,2</sub> and dimensions e<sub>1</sub> and e<sub>2</sub>; e<sub>J,0</sub> = 52 mm

B [mm]	H [mm]	full nailing						partial nailing					
		n <sub>H</sub>	n <sub>J</sub>	k <sub>H,1</sub>	k <sub>H,2</sub>	e <sub>1</sub> [mm]	e <sub>2</sub> [mm]	n <sub>H</sub>	n <sub>J</sub>	k <sub>H,1</sub>	k <sub>H,2</sub>	e <sub>1</sub> [mm]	e <sub>2</sub> [mm]
51	315	40	22	113	50,0	2392	3952	20	11	55,6	24,4	1046	2510
60	310	40	22	110	50,0	2581	3954	20	11	54,1	24,4	1125	2411
62	309	40	22	109	50,0	2625	3958	20	11	53,8	24,4	1144	2395
64	308	40	22	108	50,0	2670	3963	20	11	53,5	24,4	1164	2380
66	307	40	22	108	50,0	2716	3969	20	11	53,1	24,4	1183	2367
68	306	40	22	107	50,0	2763	3976	20	11	52,8	24,4	1204	2355
70	305	40	22	106	50,0	2810	3984	20	11	52,5	24,4	1224	2344
72	304	40	22	106	50,0	2859	3994	20	11	52,2	24,4	1245	2335
73	304	40	22	105	50,0	2883	3998	20	11	52,0	24,4	1256	2331
74	303	40	22	105	50,0	2908	4003	20	11	51,8	24,4	1267	2327
76	302	40	22	104	50,0	2958	4014	20	11	51,5	24,4	1289	2320
78	301	40	22	104	50,0	3009	4026	20	11	51,2	24,4	1311	2314

B [mm]	H [mm]	full nailing						partial nailing					
		n <sub>H</sub>	n <sub>J</sub>	k <sub>H,1</sub>	k <sub>H,2</sub>	e <sub>1</sub> [mm]	e <sub>2</sub> [mm]	n <sub>H</sub>	n <sub>J</sub>	k <sub>H,1</sub>	k <sub>H,2</sub>	e <sub>1</sub> [mm]	e <sub>2</sub> [mm]
80	300	40	22	103	50,0	3061	4038	20	11	50,9	24,4	1334	2309
82	299	40	22	103	50,0	3113	4052	20	11	50,5	24,4	1358	2305
84	298	40	22	102	50,0	3167	4065	20	11	50,2	24,4	1381	2302
86	297	40	22	101	50,0	3221	4080	20	11	49,9	24,4	1406	2300
88	296	40	22	101	50,0	3276	4095	20	11	49,6	24,4	1430	2299
90	295	40	22	99,9	50,0	3332	4111	20	11	49,2	24,4	1455	2298
92	294	40	22	99,3	50,0	3389	4128	20	11	48,9	24,4	1481	2298
94	293	40	22	98,6	50,0	3447	4145	20	11	48,6	24,4	1507	2299
96	292	40	22	98,0	50,0	3505	4163	20	11	48,3	24,4	1533	2300
98	291	40	22	97,4	50,0	3565	4181	20	11	48,0	24,4	1560	2302
100	290	40	22	96,7	50,0	3625	4200	20	11	47,6	24,4	1588	2305
102	289	40	22	96,1	50,0	3686	4219	20	11	47,3	24,4	1615	2308
104	288	40	22	95,4	50,0	3748	4239	20	11	47,0	24,4	1644	2311
106	287	40	22	94,8	50,0	3811	4259	20	11	46,7	24,4	1672	2315
108	286	40	22	94,2	50,0	3874	4280	20	11	46,4	24,4	1701	2320
110	285	40	22	93,5	50,0	3939	4301	20	11	46,0	24,4	1731	2325
112	284	40	22	92,9	50,0	4004	4322	20	11	45,7	24,4	1761	2331
114	283	40	22	92,3	50,0	4070	4344	20	11	45,4	24,4	1791	2337
116	282	40	22	91,6	50,0	4137	4367	20	11	45,1	24,4	1822	2343
118	281	40	22	91,0	50,0	4205	4389	20	11	44,8	24,4	1854	2350
120	280	40	22	90,4	50,0	4273	4413	20	11	44,5	24,4	1885	2357
122	279	40	22	89,8	50,0	4343	4436	20	11	44,1	24,4	1918	2364
124	278	40	22	89,1	50,0	4413	4460	20	11	43,8	24,4	1950	2372
126	277	40	22	88,5	50,0	4484	4484	20	11	43,5	24,4	1983	2380
128	276	40	22	87,9	50,0	4556	4509	20	11	43,2	24,4	2017	2388
130	275	40	22	87,3	50,0	4629	4534	20	11	42,9	24,4	2051	2397
132	274	40	22	86,6	50,0	4703	4559	20	11	42,6	24,4	2085	2406
134	273	40	22	86,0	50,0	4777	4584	20	11	42,3	24,4	2120	2415
136	272	40	22	85,4	50,0	4853	4610	20	11	42,0	24,4	2156	2425
138	271	40	22	84,8	50,0	4929	4636	20	11	41,7	24,4	2191	2435
140	270	40	22	84,2	50,0	5006	4662	20	11	41,3	24,4	2228	2445
142	269	40	22	83,5	50,0	5084	4689	20	11	41,0	24,4	2264	2455
144	268	40	22	82,9	50,0	5163	4716	20	11	40,7	24,4	2301	2466
146	267	40	22	82,3	50,0	5242	4743	20	11	40,4	24,4	2339	2476
148	266	40	22	81,7	50,0	5323	4770	20	11	40,1	24,4	2377	2487
150	265	40	22	81,1	50,0	5404	4798	20	11	39,8	24,4	2415	2499
152	264	40	22	80,5	50,0	5486	4826	20	11	39,5	24,4	2454	2510
154	263	40	22	79,9	50,0	5569	4854	20	11	39,2	24,4	2494	2522
156	262	40	22	79,3	50,0	5653	4882	20	11	38,9	24,4	2533	2533
158	261	40	22	78,6	50,0	5737	4910	20	11	38,6	24,4	2574	2545
160	260	40	22	78,0	50,0	5823	4939	20	11	38,3	24,4	2614	2557
162	259	40	22	77,4	50,0	5909	4968	20	11	38,0	24,4	2655	2570
164	258	40	22	76,8	50,0	5996	4997	20	11	37,7	24,4	2697	2582
166	257	40	22	76,2	50,0	6084	5026	20	11	37,4	24,4	2739	2595
168	256	40	22	75,6	50,0	6173	5056	20	11	37,1	24,4	2781	2608
170	255	40	22	75,0	50,0	6263	5085	20	11	36,8	24,4	2824	2620
172	254	40	22	74,4	50,0	6353	5115	20	11	36,5	24,4	2868	2633
174	253	40	22	73,8	50,0	6445	5145	20	11	36,2	24,4	2911	2647
176	252	40	22	73,3	50,0	6537	5175	20	11	35,9	24,4	2956	2660
178	251	40	22	72,7	50,0	6630	5205	20	11	35,6	24,4	3000	2673
180	250	40	22	72,1	50,0	6724	5236	20	11	35,3	24,4	3045	2687
182	249	40	22	71,5	50,0	6819	5266	20	11	35,0	24,4	3091	2701

B [mm]	H [mm]	full nailing						partial nailing					
		n <sub>H</sub>	n <sub>J</sub>	k <sub>H,1</sub>	k <sub>H,2</sub>	e <sub>1</sub> [mm]	e <sub>2</sub> [mm]	n <sub>H</sub>	n <sub>J</sub>	k <sub>H,1</sub>	k <sub>H,2</sub>	e <sub>1</sub> [mm]	e <sub>2</sub> [mm]
184	248	40	22	70,9	50,0	6914	5297	20	11	34,7	24,4	3137	2715
186	247	40	22	70,3	50,0	7011	5328	20	11	34,4	24,4	3183	2729
188	246	40	22	69,7	50,0	7108	5359	20	11	34,1	24,4	3230	2743
190	245	40	22	69,1	50,0	7206	5390	20	11	33,9	24,4	3278	2757
192	244	40	22	68,6	50,0	7305	5422	20	11	33,6	24,4	3325	2771
194	243	40	22	68,0	50,0	7405	5453	20	11	33,3	24,4	3374	2786
196	242	40	22	67,4	50,0	7505	5485	20	11	33,0	24,4	3422	2800
198	241	40	22	66,8	50,0	7607	5516	20	11	32,7	24,4	3471	2815
200	240	40	22	66,3	50,0	7709	5548	20	11	32,4	24,4	3521	2829

Table B40: Joist hanger Blank 720 (200 x 260): Form factors k<sub>H,1</sub> and k<sub>H,2</sub> and dimensions e<sub>1</sub> and e<sub>2</sub>; e<sub>J,0</sub> = 52 mm

B [mm]	H [mm]	full nailing						partial nailing					
		n <sub>H</sub>	n <sub>J</sub>	k <sub>H,1</sub>	k <sub>H,2</sub>	e <sub>1</sub> [mm]	e <sub>2</sub> [mm]	n <sub>H</sub>	n <sub>J</sub>	k <sub>H,1</sub>	k <sub>H,2</sub>	e <sub>1</sub> [mm]	e <sub>2</sub> [mm]
51	335	44	24	129	60,6	2674	4883	22	12	63,7	29,6	1189	3172
60	330	44	24	126	60,6	2862	4846	22	12	62,1	29,6	1268	3019
62	329	44	24	125	60,6	2906	4843	22	12	61,7	29,6	1287	2993
64	328	44	24	124	60,6	2951	4841	22	12	61,3	29,6	1306	2968
66	327	44	24	124	60,6	2996	4840	22	12	61,0	29,6	1326	2946
68	326	44	24	123	60,6	3043	4841	22	12	60,6	29,6	1346	2925
70	325	44	24	122	60,6	3090	4843	22	12	60,3	29,6	1366	2906
72	324	44	24	121	60,6	3138	4846	22	12	59,9	29,6	1387	2889
73	324	44	24	121	60,6	3163	4848	22	12	59,7	29,6	1397	2881
74	323	44	24	121	60,6	3187	4850	22	12	59,6	29,6	1408	2874
76	322	44	24	120	60,6	3237	4856	22	12	59,2	29,6	1430	2860
78	321	44	24	119	60,6	3288	4862	22	12	58,9	29,6	1452	2847
80	320	44	24	119	60,6	3339	4870	22	12	58,5	29,6	1475	2836
82	319	44	24	118	60,6	3392	4879	22	12	58,1	29,6	1498	2826
84	318	44	24	117	60,6	3445	4888	22	12	57,8	29,6	1522	2818
86	317	44	24	116	60,6	3499	4899	22	12	57,4	29,6	1546	2810
88	316	44	24	116	60,6	3554	4910	22	12	57,1	29,6	1570	2803
90	315	44	24	115	60,6	3610	4922	22	12	56,7	29,6	1595	2798
92	314	44	24	114	60,6	3666	4935	22	12	56,4	29,6	1620	2793
94	313	44	24	114	60,6	3724	4949	22	12	56,0	29,6	1646	2790
96	312	44	24	113	60,6	3782	4964	22	12	55,7	29,6	1672	2787
98	311	44	24	112	60,6	3841	4979	22	12	55,3	29,6	1699	2785
100	310	44	24	112	60,6	3901	4995	22	12	55,0	29,6	1726	2783
102	309	44	24	111	60,6	3962	5012	22	12	54,7	29,6	1753	2783
104	308	44	24	110	60,6	4023	5029	22	12	54,3	29,6	1781	2783
106	307	44	24	110	60,6	4086	5047	22	12	54,0	29,6	1810	2784
108	306	44	24	109	60,6	4149	5066	22	12	53,6	29,6	1838	2785
110	305	44	24	108	60,6	4213	5085	22	12	53,3	29,6	1868	2787
112	304	44	24	107	60,6	4278	5105	22	12	52,9	29,6	1897	2790
114	303	44	24	107	60,6	4344	5125	22	12	52,6	29,6	1927	2793
116	302	44	24	106	60,6	4410	5146	22	12	52,2	29,6	1958	2797
118	301	44	24	105	60,6	4478	5167	22	12	51,9	29,6	1989	2801
120	300	44	24	105	60,6	4546	5189	22	12	51,6	29,6	2020	2806
122	299	44	24	104	60,6	4615	5211	22	12	51,2	29,6	2052	2811
124	298	44	24	103	60,6	4685	5234	22	12	50,9	29,6	2085	2817
126	297	44	24	103	60,6	4756	5257	22	12	50,5	29,6	2118	2823
128	296	44	24	102	60,6	4828	5280	22	12	50,2	29,6	2151	2830
130	295	44	24	101	60,6	4900	5304	22	12	49,9	29,6	2184	2837



B [mm]	H [mm]	full nailing						partial nailing					
		n <sub>H</sub>	n <sub>J</sub>	k <sub>H,1</sub>	k <sub>H,2</sub>	e <sub>1</sub> [mm]	e <sub>2</sub> [mm]	n <sub>H</sub>	n <sub>J</sub>	k <sub>H,1</sub>	k <sub>H,2</sub>	e <sub>1</sub> [mm]	e <sub>2</sub> [mm]
132	294	44	24	101	60,6	4974	5329	22	12	49,5	29,6	2218	2844
134	293	44	24	100	60,6	5048	5354	22	12	49,2	29,6	2253	2852
136	292	44	24	99,3	60,6	5123	5379	22	12	48,8	29,6	2288	2860
138	291	44	24	98,6	60,6	5199	5405	22	12	48,5	29,6	2323	2868
140	290	44	24	97,9	60,6	5275	5431	22	12	48,2	29,6	2359	2877
142	289	44	24	97,3	60,6	5353	5457	22	12	47,8	29,6	2396	2886
144	288	44	24	96,6	60,6	5431	5484	22	12	47,5	29,6	2432	2896
146	287	44	24	95,9	60,6	5510	5510	22	12	47,2	29,6	2470	2905
148	286	44	24	95,3	60,6	5591	5538	22	12	46,8	29,6	2507	2915
150	285	44	24	94,6	60,6	5671	5565	22	12	46,5	29,6	2545	2925
152	284	44	24	93,9	60,6	5753	5593	22	12	46,2	29,6	2584	2936
154	283	44	24	93,3	60,6	5836	5622	22	12	45,8	29,6	2623	2947
156	282	44	24	92,6	60,6	5919	5650	22	12	45,5	29,6	2662	2958
158	281	44	24	91,9	60,6	6003	5679	22	12	45,2	29,6	2702	2969
160	280	44	24	91,3	60,6	6088	5708	22	12	44,8	29,6	2742	2981
162	279	44	24	90,6	60,6	6174	5737	22	12	44,5	29,6	2783	2992
164	278	44	24	90,0	60,6	6261	5767	22	12	44,2	29,6	2824	3004
166	277	44	24	89,3	60,6	6349	5797	22	12	43,9	29,6	2866	3016
168	276	44	24	88,7	60,6	6437	5827	22	12	43,5	29,6	2908	3029
170	275	44	24	88,0	60,6	6526	5857	22	12	43,2	29,6	2950	3041
172	274	44	24	87,4	60,6	6616	5887	22	12	42,9	29,6	2993	3054
174	273	44	24	86,7	60,6	6707	5918	22	12	42,6	29,6	3036	3067
176	272	44	24	86,1	60,6	6799	5949	22	12	42,2	29,6	3080	3080
178	271	44	24	85,4	60,6	6892	5980	22	12	41,9	29,6	3124	3093
180	270	44	24	84,8	60,6	6985	6012	22	12	41,6	29,6	3169	3107
182	269	44	24	84,1	60,6	7079	6043	22	12	41,3	29,6	3214	3120
184	268	44	24	83,5	60,6	7175	6075	22	12	41,0	29,6	3260	3134
186	267	44	24	82,9	60,6	7270	6107	22	12	40,6	29,6	3306	3148
188	266	44	24	82,2	60,6	7367	6139	22	12	40,3	29,6	3352	3162
190	265	44	24	81,6	60,6	7465	6172	22	12	40,0	29,6	3399	3176
192	264	44	24	81,0	60,6	7563	6204	22	12	39,7	29,6	3446	3191
194	263	44	24	80,3	60,6	7663	6237	22	12	39,4	29,6	3494	3205
196	262	44	24	79,7	60,6	7763	6270	22	12	39,1	29,6	3542	3220
198	261	44	24	79,1	60,6	7864	6303	22	12	38,8	29,6	3591	3235
200	260	44	24	78,4	60,6	7966	6336	22	12	38,4	29,6	3640	3250

Table B41: Joist hanger Blank 760 (200 x 280): Form factors k<sub>H,1</sub> and k<sub>H,2</sub> and dimensions e<sub>1</sub> and e<sub>2</sub>; e<sub>J,0</sub> = 52 mm

B [mm]	H [mm]	full nailing						partial nailing					
		n <sub>H</sub>	n <sub>J</sub>	k <sub>H,1</sub>	k <sub>H,2</sub>	e <sub>1</sub> [mm]	e <sub>2</sub> [mm]	n <sub>H</sub>	n <sub>J</sub>	k <sub>H,1</sub>	k <sub>H,2</sub>	e <sub>1</sub> [mm]	e <sub>2</sub> [mm]
51	355	48	26	146	72,3	2983	5967	24	13	72,2	35,4	1347	3951
60	350	48	26	143	72,3	3170	5881	24	13	70,5	35,4	1425	3732
62	349	48	26	142	72,3	3214	5867	24	13	70,1	35,4	1443	3692
64	348	48	26	141	72,3	3259	5856	24	13	69,7	35,4	1462	3656
66	347	48	26	140	72,3	3304	5846	24	13	69,3	35,4	1482	3622
68	346	48	26	140	72,3	3351	5838	24	13	68,9	35,4	1502	3591
70	345	48	26	139	72,3	3398	5832	24	13	68,6	35,4	1522	3562
72	344	48	26	138	72,3	3446	5828	24	13	68,2	35,4	1543	3535
73	344	48	26	138	72,3	3470	5826	24	13	68,0	35,4	1553	3523
74	343	48	26	137	72,3	3495	5824	24	13	67,8	35,4	1564	3511
76	342	48	26	137	72,3	3544	5823	24	13	67,4	35,4	1585	3488
78	341	48	26	136	72,3	3595	5823	24	13	67,0	35,4	1607	3467

B [mm]	H [mm]	full nailing						partial nailing					
		n <sub>H</sub>	n <sub>J</sub>	k <sub>H,1</sub>	k <sub>H,2</sub>	e <sub>1</sub> [mm]	e <sub>2</sub> [mm]	n <sub>H</sub>	n <sub>J</sub>	k <sub>H,1</sub>	k <sub>H,2</sub>	e <sub>1</sub> [mm]	e <sub>2</sub> [mm]
80	340	48	26	135	72,3	3646	5824	24	13	66,7	35,4	1630	3448
82	339	48	26	134	72,3	3698	5826	24	13	66,3	35,4	1653	3430
84	338	48	26	134	72,3	3751	5830	24	13	65,9	35,4	1676	3415
86	337	48	26	133	72,3	3805	5835	24	13	65,5	35,4	1700	3400
88	336	48	26	132	72,3	3860	5841	24	13	65,1	35,4	1724	3387
90	335	48	26	131	72,3	3915	5848	24	13	64,8	35,4	1749	3375
92	334	48	26	131	72,3	3972	5856	24	13	64,4	35,4	1774	3364
94	333	48	26	130	72,3	4029	5865	24	13	64,0	35,4	1799	3355
96	332	48	26	129	72,3	4087	5875	24	13	63,6	35,4	1825	3347
98	331	48	26	128	72,3	4146	5886	24	13	63,2	35,4	1852	3339
100	330	48	26	127	72,3	4205	5898	24	13	62,9	35,4	1879	3333
102	329	48	26	127	72,3	4266	5911	24	13	62,5	35,4	1906	3328
104	328	48	26	126	72,3	4327	5924	24	13	62,1	35,4	1934	3324
106	327	48	26	125	72,3	4390	5939	24	13	61,7	35,4	1962	3320
108	326	48	26	125	72,3	4453	5954	24	13	61,4	35,4	1990	3317
110	325	48	26	124	72,3	4516	5970	24	13	61,0	35,4	2019	3315
112	324	48	26	123	72,3	4581	5987	24	13	60,6	35,4	2049	3314
114	323	48	26	122	72,3	4647	6004	24	13	60,3	35,4	2079	3314
116	322	48	26	122	72,3	4713	6022	24	13	59,9	35,4	2109	3314
118	321	48	26	121	72,3	4780	6041	24	13	59,5	35,4	2140	3315
120	320	48	26	120	72,3	4848	6060	24	13	59,2	35,4	2171	3317
122	319	48	26	119	72,3	4917	6080	24	13	58,8	35,4	2203	3319
124	318	48	26	119	72,3	4987	6101	24	13	58,4	35,4	2235	3322
126	317	48	26	118	72,3	5057	6122	24	13	58,0	35,4	2267	3325
128	316	48	26	117	72,3	5129	6144	24	13	57,7	35,4	2300	3329
130	315	48	26	116	72,3	5201	6166	24	13	57,3	35,4	2334	3334
132	314	48	26	116	72,3	5274	6189	24	13	56,9	35,4	2367	3339
134	313	48	26	115	72,3	5348	6212	24	13	56,6	35,4	2402	3344
136	312	48	26	114	72,3	5423	6236	24	13	56,2	35,4	2436	3350
138	311	48	26	113	72,3	5498	6260	24	13	55,9	35,4	2471	3356
140	310	48	26	113	72,3	5575	6285	24	13	55,5	35,4	2507	3363
142	309	48	26	112	72,3	5652	6310	24	13	55,1	35,4	2543	3370
144	308	48	26	111	72,3	5730	6336	24	13	54,8	35,4	2579	3378
146	307	48	26	111	72,3	5809	6362	24	13	54,4	35,4	2616	3386
148	306	48	26	110	72,3	5888	6388	24	13	54,1	35,4	2654	3394
150	305	48	26	109	72,3	5969	6415	24	13	53,7	35,4	2691	3403
152	304	48	26	108	72,3	6050	6443	24	13	53,3	35,4	2730	3412
154	303	48	26	108	72,3	6133	6470	24	13	53,0	35,4	2768	3421
156	302	48	26	107	72,3	6216	6498	24	13	52,6	35,4	2807	3431
158	301	48	26	106	72,3	6300	6527	24	13	52,3	35,4	2847	3441
160	300	48	26	106	72,3	6384	6555	24	13	51,9	35,4	2887	3451
162	299	48	26	105	72,3	6470	6584	24	13	51,6	35,4	2927	3462
164	298	48	26	104	72,3	6556	6614	24	13	51,2	35,4	2968	3473
166	297	48	26	103	72,3	6643	6643	24	13	50,8	35,4	3009	3484
168	296	48	26	103	72,3	6732	6674	24	13	50,5	35,4	3051	3496
170	295	48	26	102	72,3	6820	6704	24	13	50,1	35,4	3093	3507
172	294	48	26	101	72,3	6910	6735	24	13	49,8	35,4	3135	3519
174	293	48	26	101	72,3	7001	6765	24	13	49,4	35,4	3178	3532
176	292	48	26	99,9	72,3	7092	6797	24	13	49,1	35,4	3222	3544
178	291	48	26	99,2	72,3	7184	6828	24	13	48,7	35,4	3266	3557
180	290	48	26	98,5	72,3	7277	6860	24	13	48,4	35,4	3310	3570
182	289	48	26	97,8	72,3	7371	6892	24	13	48,1	35,4	3355	3583

B [mm]	H [mm]	full nailing						partial nailing					
		n <sub>H</sub>	n <sub>J</sub>	k <sub>H,1</sub>	k <sub>H,2</sub>	e <sub>1</sub> [mm]	e <sub>2</sub> [mm]	n <sub>H</sub>	n <sub>J</sub>	k <sub>H,1</sub>	k <sub>H,2</sub>	e <sub>1</sub> [mm]	e <sub>2</sub> [mm]
184	288	48	26	97,1	72,3	7466	6924	24	13	47,7	35,4	3400	3596
186	287	48	26	96,4	72,3	7562	6957	24	13	47,4	35,4	3445	3610
188	286	48	26	95,8	72,3	7658	6990	24	13	47,0	35,4	3491	3623
190	285	48	26	95,1	72,3	7755	7023	24	13	46,7	35,4	3538	3637
192	284	48	26	94,4	72,3	7853	7056	24	13	46,3	35,4	3585	3651
194	283	48	26	93,7	72,3	7952	7089	24	13	46,0	35,4	3632	3666
196	282	48	26	93,0	72,3	8052	7123	24	13	45,7	35,4	3680	3680
198	281	48	26	92,3	72,3	8153	7157	24	13	45,3	35,4	3728	3695
200	280	48	26	91,7	72,3	8254	7191	24	13	45,0	35,4	3777	3709

Table B42: Joist hanger Blank 800 (200 x 300): Form factors k<sub>H,1</sub> and k<sub>H,2</sub> and dimensions e<sub>1</sub> and e<sub>2</sub>; e<sub>J,0</sub> = 52 mm

B [mm]	H [mm]	full nailing						partial nailing					
		n <sub>H</sub>	n <sub>J</sub>	k <sub>H,1</sub>	k <sub>H,2</sub>	e <sub>1</sub> [mm]	e <sub>2</sub> [mm]	n <sub>H</sub>	n <sub>J</sub>	k <sub>H,1</sub>	k <sub>H,2</sub>	e <sub>1</sub> [mm]	e <sub>2</sub> [mm]
51	375	52	28	164	85,0	3320	7218	26	14	81,3	41,7	1518	4858
60	370	52	28	161	85,0	3506	7069	26	14	79,4	41,7	1596	4559
62	369	52	28	160	85,0	3550	7044	26	14	79,0	41,7	1614	4504
64	368	52	28	159	85,0	3595	7021	26	14	78,6	41,7	1633	4453
66	367	52	28	158	85,0	3640	7000	26	14	78,2	41,7	1652	4406
68	366	52	28	157	85,0	3686	6981	26	14	77,8	41,7	1672	4361
70	365	52	28	157	85,0	3733	6965	26	14	77,4	41,7	1692	4320
72	364	52	28	156	85,0	3781	6950	26	14	76,9	41,7	1713	4281
73	364	52	28	155	85,0	3805	6944	26	14	76,7	41,7	1723	4263
74	363	52	28	155	85,0	3830	6938	26	14	76,5	41,7	1734	4245
76	362	52	28	154	85,0	3879	6927	26	14	76,1	41,7	1755	4212
78	361	52	28	153	85,0	3930	6918	26	14	75,7	41,7	1777	4181
80	360	52	28	153	85,0	3981	6911	26	14	75,3	41,7	1799	4152
82	359	52	28	152	85,0	4033	6905	26	14	74,9	41,7	1822	4125
84	358	52	28	151	85,0	4086	6901	26	14	74,5	41,7	1845	4100
86	357	52	28	150	85,0	4139	6899	26	14	74,1	41,7	1869	4077
88	356	52	28	149	85,0	4194	6898	26	14	73,7	41,7	1893	4056
90	355	52	28	148	85,0	4249	6898	26	14	73,3	41,7	1917	4036
92	354	52	28	148	85,0	4305	6899	26	14	72,9	41,7	1942	4018
94	353	52	28	147	85,0	4362	6902	26	14	72,5	41,7	1968	4002
96	352	52	28	146	85,0	4420	6906	26	14	72,1	41,7	1993	3987
98	351	52	28	145	85,0	4479	6912	26	14	71,7	41,7	2020	3973
100	350	52	28	144	85,0	4538	6918	26	14	71,3	41,7	2046	3960
102	349	52	28	144	85,0	4598	6925	26	14	70,8	41,7	2073	3949
104	348	52	28	143	85,0	4660	6934	26	14	70,4	41,7	2101	3939
106	347	52	28	142	85,0	4722	6944	26	14	70,0	41,7	2129	3930
108	346	52	28	141	85,0	4784	6954	26	14	69,6	41,7	2157	3922
110	345	52	28	140	85,0	4848	6966	26	14	69,2	41,7	2186	3915
112	344	52	28	140	85,0	4913	6978	26	14	68,8	41,7	2215	3909
114	343	52	28	139	85,0	4978	6991	26	14	68,4	41,7	2245	3904
116	342	52	28	138	85,0	5044	7006	26	14	68,1	41,7	2275	3900
118	341	52	28	137	85,0	5111	7021	26	14	67,7	41,7	2306	3897
120	340	52	28	136	85,0	5179	7036	26	14	67,3	41,7	2337	3894
122	339	52	28	136	85,0	5247	7053	26	14	66,9	41,7	2368	3893
124	338	52	28	135	85,0	5317	7070	26	14	66,5	41,7	2400	3892
126	337	52	28	134	85,0	5387	7088	26	14	66,1	41,7	2432	3891
128	336	52	28	133	85,0	5458	7107	26	14	65,7	41,7	2465	3892
130	335	52	28	132	85,0	5530	7127	26	14	65,3	41,7	2498	3893

B [mm]	H [mm]	full nailing						partial nailing					
		n <sub>H</sub>	n <sub>J</sub>	k <sub>H,1</sub>	k <sub>H,2</sub>	e <sub>1</sub> [mm]	e <sub>2</sub> [mm]	n <sub>H</sub>	n <sub>J</sub>	k <sub>H,1</sub>	k <sub>H,2</sub>	e <sub>1</sub> [mm]	e <sub>2</sub> [mm]
132	334	52	28	132	85,0	5603	7147	26	14	64,9	41,7	2532	3895
134	333	52	28	131	85,0	5677	7168	26	14	64,5	41,7	2566	3897
136	332	52	28	130	85,0	5751	7189	26	14	64,1	41,7	2600	3900
138	331	52	28	129	85,0	5826	7211	26	14	63,7	41,7	2635	3904
140	330	52	28	129	85,0	5903	7234	26	14	63,3	41,7	2670	3908
142	329	52	28	128	85,0	5980	7257	26	14	62,9	41,7	2706	3912
144	328	52	28	127	85,0	6057	7281	26	14	62,6	41,7	2742	3917
146	327	52	28	126	85,0	6136	7305	26	14	62,2	41,7	2779	3923
148	326	52	28	125	85,0	6215	7330	26	14	61,8	41,7	2816	3929
150	325	52	28	125	85,0	6296	7355	26	14	61,4	41,7	2853	3936
152	324	52	28	124	85,0	6377	7381	26	14	61,0	41,7	2891	3943
154	323	52	28	123	85,0	6459	7407	26	14	60,6	41,7	2930	3950
156	322	52	28	122	85,0	6542	7434	26	14	60,2	41,7	2968	3958
158	321	52	28	122	85,0	6625	7461	26	14	59,9	41,7	3008	3966
160	320	52	28	121	85,0	6710	7488	26	14	59,5	41,7	3047	3975
162	319	52	28	120	85,0	6795	7517	26	14	59,1	41,7	3087	3984
164	318	52	28	119	85,0	6881	7545	26	14	58,7	41,7	3128	3993
166	317	52	28	119	85,0	6968	7574	26	14	58,3	41,7	3169	4003
168	316	52	28	118	85,0	7056	7603	26	14	58,0	41,7	3210	4013
170	315	52	28	117	85,0	7144	7633	26	14	57,6	41,7	3252	4023
172	314	52	28	116	85,0	7234	7663	26	14	57,2	41,7	3294	4034
174	313	52	28	116	85,0	7324	7693	26	14	56,8	41,7	3337	4045
176	312	52	28	115	85,0	7415	7724	26	14	56,5	41,7	3380	4056
178	311	52	28	114	85,0	7507	7755	26	14	56,1	41,7	3424	4068
180	310	52	28	113	85,0	7600	7787	26	14	55,7	41,7	3468	4079
182	309	52	28	113	85,0	7694	7819	26	14	55,3	41,7	3512	4092
184	308	52	28	112	85,0	7788	7851	26	14	55,0	41,7	3557	4104
186	307	52	28	111	85,0	7883	7883	26	14	54,6	41,7	3602	4117
188	306	52	28	110	85,0	7979	7916	26	14	54,2	41,7	3648	4130
190	305	52	28	110	85,0	8076	7949	26	14	53,9	41,7	3694	4143
192	304	52	28	109	85,0	8174	7982	26	14	53,5	41,7	3741	4156
194	303	52	28	108	85,0	8273	8016	26	14	53,1	41,7	3788	4170
196	302	52	28	107	85,0	8372	8050	26	14	52,8	41,7	3835	4184
198	301	52	28	107	85,0	8472	8084	26	14	52,4	41,7	3883	4198
200	300	52	28	106	85,0	8573	8119	26	14	52,0	41,7	3931	4212

Table B43: Joist hanger Blank 840 (200 x 320): Form factors k<sub>H,1</sub> and k<sub>H,2</sub> and dimensions e<sub>1</sub> and e<sub>2</sub>; e<sub>J,0</sub> = 52 mm

B [mm]	H [mm]	full nailing						partial nailing					
		n <sub>H</sub>	n <sub>J</sub>	k <sub>H,1</sub>	k <sub>H,2</sub>	e <sub>1</sub> [mm]	e <sub>2</sub> [mm]	n <sub>H</sub>	n <sub>J</sub>	k <sub>H,1</sub>	k <sub>H,2</sub>	e <sub>1</sub> [mm]	e <sub>2</sub> [mm]
51	395	56	30	184	98,7	3684	8650	28	15	90,8	48,5	1703	5903
60	390	56	30	180	98,7	3870	8426	28	15	88,8	48,5	1780	5509
62	389	56	30	179	98,7	3913	8386	28	15	88,4	48,5	1798	5437
64	388	56	30	178	98,7	3958	8348	28	15	88,0	48,5	1817	5368
66	387	56	30	177	98,7	4003	8314	28	15	87,5	48,5	1836	5304
68	386	56	30	176	98,7	4049	8282	28	15	87,1	48,5	1856	5245
70	385	56	30	175	98,7	4096	8253	28	15	86,6	48,5	1876	5188
72	384	56	30	174	98,7	4144	8226	28	15	86,2	48,5	1896	5136
73	384	56	30	174	98,7	4168	8214	28	15	86,0	48,5	1907	5111
74	383	56	30	174	98,7	4192	8202	28	15	85,8	48,5	1917	5086
76	382	56	30	173	98,7	4241	8180	28	15	85,3	48,5	1938	5040
78	381	56	30	172	98,7	4292	8160	28	15	84,9	48,5	1960	4997

B [mm]	H [mm]	full nailing						partial nailing					
		n <sub>H</sub>	n <sub>J</sub>	k <sub>H,1</sub>	k <sub>H,2</sub>	e <sub>1</sub> [mm]	e <sub>2</sub> [mm]	n <sub>H</sub>	n <sub>J</sub>	k <sub>H,1</sub>	k <sub>H,2</sub>	e <sub>1</sub> [mm]	e <sub>2</sub> [mm]
80	380	56	30	171	98,7	4343	8143	28	15	84,5	48,5	1982	4956
82	379	56	30	170	98,7	4395	8127	28	15	84,0	48,5	2005	4918
84	378	56	30	169	98,7	4447	8113	28	15	83,6	48,5	2028	4882
86	377	56	30	168	98,7	4501	8101	28	15	83,2	48,5	2052	4849
88	376	56	30	167	98,7	4555	8091	28	15	82,7	48,5	2075	4818
90	375	56	30	167	98,7	4610	8083	28	15	82,3	48,5	2100	4789
92	374	56	30	166	98,7	4666	8076	28	15	81,9	48,5	2125	4762
94	373	56	30	165	98,7	4723	8071	28	15	81,4	48,5	2150	4737
96	372	56	30	164	98,7	4781	8068	28	15	81,0	48,5	2175	4713
98	371	56	30	163	98,7	4839	8065	28	15	80,6	48,5	2201	4692
100	370	56	30	162	98,7	4899	8065	28	15	80,1	48,5	2228	4671
102	369	56	30	161	98,7	4959	8065	28	15	79,7	48,5	2255	4653
104	368	56	30	161	98,7	5020	8067	28	15	79,3	48,5	2282	4636
106	367	56	30	160	98,7	5081	8071	28	15	78,9	48,5	2310	4620
108	366	56	30	159	98,7	5144	8075	28	15	78,4	48,5	2338	4606
110	365	56	30	158	98,7	5208	8081	28	15	78,0	48,5	2367	4592
112	364	56	30	157	98,7	5272	8088	28	15	77,6	48,5	2396	4580
114	363	56	30	156	98,7	5337	8095	28	15	77,1	48,5	2425	4570
116	362	56	30	155	98,7	5403	8104	28	15	76,7	48,5	2455	4560
118	361	56	30	155	98,7	5470	8114	28	15	76,3	48,5	2486	4551
120	360	56	30	154	98,7	5537	8125	28	15	75,9	48,5	2517	4544
122	359	56	30	153	98,7	5606	8137	28	15	75,5	48,5	2548	4537
124	358	56	30	152	98,7	5675	8150	28	15	75,0	48,5	2579	4531
126	357	56	30	151	98,7	5745	8164	28	15	74,6	48,5	2612	4527
128	356	56	30	150	98,7	5816	8179	28	15	74,2	48,5	2644	4523
130	355	56	30	150	98,7	5888	8194	28	15	73,8	48,5	2677	4520
132	354	56	30	149	98,7	5960	8211	28	15	73,4	48,5	2710	4517
134	353	56	30	148	98,7	6034	8228	28	15	72,9	48,5	2744	4516
136	352	56	30	147	98,7	6108	8246	28	15	72,5	48,5	2778	4515
138	351	56	30	146	98,7	6183	8265	28	15	72,1	48,5	2813	4515
140	350	56	30	145	98,7	6259	8284	28	15	71,7	48,5	2848	4516
142	349	56	30	145	98,7	6336	8304	28	15	71,3	48,5	2884	4517
144	348	56	30	144	98,7	6413	8325	28	15	70,9	48,5	2920	4519
146	347	56	30	143	98,7	6492	8347	28	15	70,4	48,5	2956	4521
148	346	56	30	142	98,7	6571	8369	28	15	70,0	48,5	2993	4524
150	345	56	30	141	98,7	6651	8392	28	15	69,6	48,5	3030	4528
152	344	56	30	140	98,7	6732	8415	28	15	69,2	48,5	3068	4532
154	343	56	30	140	98,7	6814	8439	28	15	68,8	48,5	3106	4537
156	342	56	30	139	98,7	6896	8464	28	15	68,4	48,5	3145	4542
158	341	56	30	138	98,7	6980	8489	28	15	68,0	48,5	3184	4548
160	340	56	30	137	98,7	7064	8515	28	15	67,6	48,5	3223	4554
162	339	56	30	136	98,7	7149	8541	28	15	67,2	48,5	3263	4561
164	338	56	30	136	98,7	7235	8568	28	15	66,8	48,5	3303	4568
166	337	56	30	135	98,7	7321	8595	28	15	66,4	48,5	3344	4576
168	336	56	30	134	98,7	7409	8623	28	15	65,9	48,5	3385	4584
170	335	56	30	133	98,7	7497	8651	28	15	65,5	48,5	3427	4592
172	334	56	30	132	98,7	7587	8680	28	15	65,1	48,5	3469	4601
174	333	56	30	131	98,7	7677	8709	28	15	64,7	48,5	3511	4610
176	332	56	30	131	98,7	7767	8738	28	15	64,3	48,5	3554	4620
178	331	56	30	130	98,7	7859	8768	28	15	63,9	48,5	3597	4630
180	330	56	30	129	98,7	7952	8799	28	15	63,5	48,5	3641	4640
182	329	56	30	128	98,7	8045	8830	28	15	63,1	48,5	3685	4651

B [mm]	H [mm]	full nailing						partial nailing					
		n <sub>H</sub>	n <sub>J</sub>	k <sub>H,1</sub>	k <sub>H,2</sub>	e <sub>1</sub> [mm]	e <sub>2</sub> [mm]	n <sub>H</sub>	n <sub>J</sub>	k <sub>H,1</sub>	k <sub>H,2</sub>	e <sub>1</sub> [mm]	e <sub>2</sub> [mm]
184	328	56	30	127	98,7	8139	8861	28	15	62,7	48,5	3730	4662
186	327	56	30	127	98,7	8234	8893	28	15	62,3	48,5	3775	4673
188	326	56	30	126	98,7	8330	8925	28	15	62,0	48,5	3820	4685
190	325	56	30	125	98,7	8427	8957	28	15	61,6	48,5	3866	4697
192	324	56	30	124	98,7	8524	8990	28	15	61,2	48,5	3912	4709
194	323	56	30	124	98,7	8622	9023	28	15	60,8	48,5	3959	4722
196	322	56	30	123	98,7	8721	9057	28	15	60,4	48,5	4006	4735
198	321	56	30	122	98,7	8821	9091	28	15	60,0	48,5	4054	4748
200	320	56	30	121	98,7	8922	9125	28	15	59,6	48,5	4102	4761

Table B44: Joist hanger Blank 660 (220 x 220): Form factors k<sub>H,1</sub> and k<sub>H,2</sub> and dimensions e<sub>1</sub> and e<sub>2</sub>; e<sub>J,0</sub> = 52 mm

B [mm]	H [mm]	full nailing						partial nailing					
		n <sub>H</sub>	n <sub>J</sub>	k <sub>H,1</sub>	k <sub>H,2</sub>	e <sub>1</sub> [mm]	e <sub>2</sub> [mm]	n <sub>H</sub>	n <sub>J</sub>	k <sub>H,1</sub>	k <sub>H,2</sub>	e <sub>1</sub> [mm]	e <sub>2</sub> [mm]
51	305	36	20	103	40,4	2138	3160	18	10	51,1	19,6	916	1955
60	300	36	20	101	40,4	2328	3191	18	10	49,7	19,6	997	1899
62	299	36	20	100	40,4	2372	3200	18	10	49,4	19,6	1016	1890
64	298	36	20	99,5	40,4	2417	3211	18	10	49,1	19,6	1036	1883
66	297	36	20	98,9	40,4	2464	3222	18	10	48,8	19,6	1056	1877
68	296	36	20	98,3	40,4	2511	3233	18	10	48,5	19,6	1076	1871
70	295	36	20	97,7	40,4	2558	3246	18	10	48,2	19,6	1097	1867
72	294	36	20	97,1	40,4	2607	3259	18	10	47,9	19,6	1118	1864
73	294	36	20	96,8	40,4	2632	3266	18	10	47,7	19,6	1129	1863
74	293	36	20	96,5	40,4	2657	3273	18	10	47,6	19,6	1140	1862
76	292	36	20	95,9	40,4	2707	3287	18	10	47,3	19,6	1163	1860
78	291	36	20	95,3	40,4	2758	3302	18	10	47,0	19,6	1185	1859
80	290	36	20	94,7	40,4	2810	3318	18	10	46,7	19,6	1208	1859
82	289	36	20	94,1	40,4	2863	3334	18	10	46,4	19,6	1232	1860
84	288	36	20	93,5	40,4	2917	3351	18	10	46,1	19,6	1256	1861
86	287	36	20	92,9	40,4	2972	3368	18	10	45,8	19,6	1281	1863
88	286	36	20	92,3	40,4	3027	3386	18	10	45,5	19,6	1306	1865
90	285	36	20	91,7	40,4	3084	3404	18	10	45,2	19,6	1331	1868
92	284	36	20	91,1	40,4	3141	3423	18	10	44,9	19,6	1357	1872
94	283	36	20	90,5	40,4	3199	3442	18	10	44,6	19,6	1383	1876
96	282	36	20	89,9	40,4	3258	3461	18	10	44,3	19,6	1410	1880
98	281	36	20	89,3	40,4	3317	3481	18	10	44,0	19,6	1437	1885
100	280	36	20	88,7	40,4	3378	3502	18	10	43,7	19,6	1465	1890
102	279	36	20	88,1	40,4	3439	3522	18	10	43,4	19,6	1493	1896
104	278	36	20	87,5	40,4	3502	3543	18	10	43,1	19,6	1522	1902
106	277	36	20	86,9	40,4	3565	3565	18	10	42,8	19,6	1551	1908
108	276	36	20	86,4	40,4	3629	3586	18	10	42,5	19,6	1580	1915
110	275	36	20	85,8	40,4	3693	3609	18	10	42,2	19,6	1610	1922
112	274	36	20	85,2	40,4	3759	3631	18	10	41,9	19,6	1640	1930
114	273	36	20	84,6	40,4	3826	3654	18	10	41,6	19,6	1671	1938
116	272	36	20	84,0	40,4	3893	3677	18	10	41,4	19,6	1703	1946
118	271	36	20	83,4	40,4	3961	3700	18	10	41,1	19,6	1734	1954
120	270	36	20	82,8	40,4	4030	3724	18	10	40,8	19,6	1766	1963
122	269	36	20	82,3	40,4	4100	3747	18	10	40,5	19,6	1799	1972
124	268	36	20	81,7	40,4	4171	3771	18	10	40,2	19,6	1832	1981
126	267	36	20	81,1	40,4	4242	3796	18	10	39,9	19,6	1866	1990
128	266	36	20	80,5	40,4	4315	3820	18	10	39,6	19,6	1900	2000
130	265	36	20	79,9	40,4	4388	3845	18	10	39,3	19,6	1934	2009

B [mm]	H [mm]	full nailing						partial nailing					
		n <sub>H</sub>	n <sub>J</sub>	k <sub>H,1</sub>	k <sub>H,2</sub>	e <sub>1</sub> [mm]	e <sub>2</sub> [mm]	n <sub>H</sub>	n <sub>J</sub>	k <sub>H,1</sub>	k <sub>H,2</sub>	e <sub>1</sub> [mm]	e <sub>2</sub> [mm]
132	264	36	20	79,4	40,4	4462	3870	18	10	39,0	19,6	1969	2019
134	263	36	20	78,8	40,4	4537	3896	18	10	38,7	19,6	2004	2030
136	262	36	20	78,2	40,4	4613	3921	18	10	38,5	19,6	2040	2040
138	261	36	20	77,6	40,4	4690	3947	18	10	38,2	19,6	2076	2051
140	260	36	20	77,1	40,4	4767	3973	18	10	37,9	19,6	2113	2061
142	259	36	20	76,5	40,4	4845	3999	18	10	37,6	19,6	2150	2072
144	258	36	20	75,9	40,4	4925	4025	18	10	37,3	19,6	2188	2083
146	257	36	20	75,4	40,4	5005	4051	18	10	37,0	19,6	2226	2095
148	256	36	20	74,8	40,4	5086	4078	18	10	36,7	19,6	2264	2106
150	255	36	20	74,2	40,4	5167	4105	18	10	36,4	19,6	2303	2118
152	254	36	20	73,6	40,4	5250	4132	18	10	36,2	19,6	2342	2129
154	253	36	20	73,1	40,4	5333	4159	18	10	35,9	19,6	2382	2141
156	252	36	20	72,5	40,4	5418	4186	18	10	35,6	19,6	2423	2153
158	251	36	20	72,0	40,4	5503	4214	18	10	35,3	19,6	2463	2165
160	250	36	20	71,4	40,4	5589	4241	18	10	35,0	19,6	2504	2178
162	249	36	20	70,8	40,4	5676	4269	18	10	34,8	19,6	2546	2190
164	248	36	20	70,3	40,4	5763	4297	18	10	34,5	19,6	2588	2203
166	247	36	20	69,7	40,4	5852	4325	18	10	34,2	19,6	2631	2215
168	246	36	20	69,1	40,4	5941	4353	18	10	33,9	19,6	2674	2228
170	245	36	20	68,6	40,4	6031	4382	18	10	33,6	19,6	2717	2241
172	244	36	20	68,0	40,4	6122	4410	18	10	33,4	19,6	2761	2254
174	243	36	20	67,5	40,4	6214	4439	18	10	33,1	19,6	2805	2267
176	242	36	20	66,9	40,4	6307	4468	18	10	32,8	19,6	2850	2280
178	241	36	20	66,4	40,4	6401	4496	18	10	32,5	19,6	2895	2293
180	240	36	20	65,8	40,4	6495	4525	18	10	32,3	19,6	2941	2307
182	239	36	20	65,3	40,4	6590	4554	18	10	32,0	19,6	2987	2320
184	238	36	20	64,7	40,4	6687	4584	18	10	31,7	19,6	3034	2334
186	237	36	20	64,2	40,4	6784	4613	18	10	31,4	19,6	3081	2347
188	236	36	20	63,6	40,4	6881	4642	18	10	31,2	19,6	3128	2361
190	235	36	20	63,1	40,4	6980	4672	18	10	30,9	19,6	3176	2375
192	234	36	20	62,5	40,4	7080	4701	18	10	30,6	19,6	3224	2388
194	233	36	20	62,0	40,4	7180	4731	18	10	30,3	19,6	3273	2402
196	232	36	20	61,5	40,4	7281	4761	18	10	30,1	19,6	3323	2416
198	231	36	20	60,9	40,4	7383	4791	18	10	29,8	19,6	3372	2430
200	230	36	20	60,4	40,4	7486	4821	18	10	29,5	19,6	3422	2445
202	229	36	20	59,8	40,4	7590	4851	18	10	29,3	19,6	3473	2459
204	228	36	20	59,3	40,4	7695	4881	18	10	29,0	19,6	3524	2473
206	227	36	20	58,8	40,4	7800	4911	18	10	28,7	19,6	3576	2487
208	226	36	20	58,3	40,4	7906	4941	18	10	28,5	19,6	3628	2502
210	225	36	20	57,7	40,4	8013	4972	18	10	28,2	19,6	3680	2516
212	224	36	20	57,2	40,4	8121	5002	18	10	27,9	19,6	3733	2531
214	223	36	20	56,7	40,4	8230	5033	18	10	27,7	19,6	3786	2545
216	222	36	20	56,1	40,4	8340	5064	18	10	27,4	19,6	3840	2560
218	221	36	20	55,6	40,4	8451	5094	18	10	27,2	19,6	3894	2575
220	220	36	20	55,1	40,4	8562	5125	18	10	26,9	19,6	3949	2589

Table B45: Joist hanger Blank 700 (220 x 240): Form factors k<sub>H,1</sub> and k<sub>H,2</sub> and dimensions e<sub>1</sub> and e<sub>2</sub>; e<sub>J,0</sub> = 52 mm

B [mm]	H [mm]	full nailing						partial nailing					
		n <sub>H</sub>	n <sub>J</sub>	k <sub>H,1</sub>	k <sub>H,2</sub>	e <sub>1</sub> [mm]	e <sub>2</sub> [mm]	n <sub>H</sub>	n <sub>J</sub>	k <sub>H,1</sub>	k <sub>H,2</sub>	e <sub>1</sub> [mm]	e <sub>2</sub> [mm]
51	325	40	22	119	50,0	2392	3952	20	11	58,9	24,4	1046	2510
60	320	40	22	116	50,0	2581	3954	20	11	57,4	24,4	1125	2411

B [mm]	H [mm]	full nailing						partial nailing					
		n <sub>H</sub>	n <sub>J</sub>	k <sub>H,1</sub>	k <sub>H,2</sub>	e <sub>1</sub> [mm]	e <sub>2</sub> [mm]	n <sub>H</sub>	n <sub>J</sub>	k <sub>H,1</sub>	k <sub>H,2</sub>	e <sub>1</sub> [mm]	e <sub>2</sub> [mm]
62	319	40	22	116	50,0	2625	3958	20	11	57,1	24,4	1144	2395
64	318	40	22	115	50,0	2670	3963	20	11	56,8	24,4	1164	2380
66	317	40	22	114	50,0	2716	3969	20	11	56,4	24,4	1183	2367
68	316	40	22	114	50,0	2763	3976	20	11	56,1	24,4	1204	2355
70	315	40	22	113	50,0	2810	3984	20	11	55,8	24,4	1224	2344
72	314	40	22	112	50,0	2859	3994	20	11	55,4	24,4	1245	2335
73	314	40	22	112	50,0	2883	3998	20	11	55,3	24,4	1256	2331
74	313	40	22	112	50,0	2908	4003	20	11	55,1	24,4	1267	2327
76	312	40	22	111	50,0	2958	4014	20	11	54,8	24,4	1289	2320
78	311	40	22	110	50,0	3009	4026	20	11	54,4	24,4	1311	2314
80	310	40	22	110	50,0	3061	4038	20	11	54,1	24,4	1334	2309
82	309	40	22	109	50,0	3113	4052	20	11	53,8	24,4	1358	2305
84	308	40	22	108	50,0	3167	4065	20	11	53,5	24,4	1381	2302
86	307	40	22	108	50,0	3221	4080	20	11	53,1	24,4	1406	2300
88	306	40	22	107	50,0	3276	4095	20	11	52,8	24,4	1430	2299
90	305	40	22	106	50,0	3332	4111	20	11	52,5	24,4	1455	2298
92	304	40	22	106	50,0	3389	4128	20	11	52,2	24,4	1481	2298
94	303	40	22	105	50,0	3447	4145	20	11	51,8	24,4	1507	2299
96	302	40	22	105	50,0	3505	4163	20	11	51,5	24,4	1533	2300
98	301	40	22	104	50,0	3565	4181	20	11	51,2	24,4	1560	2302
100	300	40	22	103	50,0	3625	4200	20	11	50,9	24,4	1588	2305
102	299	40	22	103	50,0	3686	4219	20	11	50,5	24,4	1615	2308
104	298	40	22	102	50,0	3748	4239	20	11	50,2	24,4	1644	2311
106	297	40	22	101	50,0	3811	4259	20	11	49,9	24,4	1672	2315
108	296	40	22	101	50,0	3874	4280	20	11	49,6	24,4	1701	2320
110	295	40	22	99,9	50,0	3939	4301	20	11	49,2	24,4	1731	2325
112	294	40	22	99,3	50,0	4004	4322	20	11	48,9	24,4	1761	2331
114	293	40	22	98,6	50,0	4070	4344	20	11	48,6	24,4	1791	2337
116	292	40	22	98,0	50,0	4137	4367	20	11	48,3	24,4	1822	2343
118	291	40	22	97,4	50,0	4205	4389	20	11	48,0	24,4	1854	2350
120	290	40	22	96,7	50,0	4273	4413	20	11	47,6	24,4	1885	2357
122	289	40	22	96,1	50,0	4343	4436	20	11	47,3	24,4	1918	2364
124	288	40	22	95,4	50,0	4413	4460	20	11	47,0	24,4	1950	2372
126	287	40	22	94,8	50,0	4484	4484	20	11	46,7	24,4	1983	2380
128	286	40	22	94,2	50,0	4556	4509	20	11	46,4	24,4	2017	2388
130	285	40	22	93,5	50,0	4629	4534	20	11	46,0	24,4	2051	2397
132	284	40	22	92,9	50,0	4703	4559	20	11	45,7	24,4	2085	2406
134	283	40	22	92,3	50,0	4777	4584	20	11	45,4	24,4	2120	2415
136	282	40	22	91,6	50,0	4853	4610	20	11	45,1	24,4	2156	2425
138	281	40	22	91,0	50,0	4929	4636	20	11	44,8	24,4	2191	2435
140	280	40	22	90,4	50,0	5006	4662	20	11	44,5	24,4	2228	2445
142	279	40	22	89,8	50,0	5084	4689	20	11	44,1	24,4	2264	2455
144	278	40	22	89,1	50,0	5163	4716	20	11	43,8	24,4	2301	2466
146	277	40	22	88,5	50,0	5242	4743	20	11	43,5	24,4	2339	2476
148	276	40	22	87,9	50,0	5323	4770	20	11	43,2	24,4	2377	2487
150	275	40	22	87,3	50,0	5404	4798	20	11	42,9	24,4	2415	2499
152	274	40	22	86,6	50,0	5486	4826	20	11	42,6	24,4	2454	2510
154	273	40	22	86,0	50,0	5569	4854	20	11	42,3	24,4	2494	2522
156	272	40	22	85,4	50,0	5653	4882	20	11	42,0	24,4	2533	2533
158	271	40	22	84,8	50,0	5737	4910	20	11	41,7	24,4	2574	2545
160	270	40	22	84,2	50,0	5823	4939	20	11	41,3	24,4	2614	2557
162	269	40	22	83,5	50,0	5909	4968	20	11	41,0	24,4	2655	2570



B [mm]	H [mm]	full nailing						partial nailing					
		n <sub>H</sub>	n <sub>J</sub>	k <sub>H,1</sub>	k <sub>H,2</sub>	e <sub>1</sub> [mm]	e <sub>2</sub> [mm]	n <sub>H</sub>	n <sub>J</sub>	k <sub>H,1</sub>	k <sub>H,2</sub>	e <sub>1</sub> [mm]	e <sub>2</sub> [mm]
164	268	40	22	82,9	50,0	5996	4997	20	11	40,7	24,4	2697	2582
166	267	40	22	82,3	50,0	6084	5026	20	11	40,4	24,4	2739	2595
168	266	40	22	81,7	50,0	6173	5056	20	11	40,1	24,4	2781	2608
170	265	40	22	81,1	50,0	6263	5085	20	11	39,8	24,4	2824	2620
172	264	40	22	80,5	50,0	6353	5115	20	11	39,5	24,4	2868	2633
174	263	40	22	79,9	50,0	6445	5145	20	11	39,2	24,4	2911	2647
176	262	40	22	79,3	50,0	6537	5175	20	11	38,9	24,4	2956	2660
178	261	40	22	78,6	50,0	6630	5205	20	11	38,6	24,4	3000	2673
180	260	40	22	78,0	50,0	6724	5236	20	11	38,3	24,4	3045	2687
182	259	40	22	77,4	50,0	6819	5266	20	11	38,0	24,4	3091	2701
184	258	40	22	76,8	50,0	6914	5297	20	11	37,7	24,4	3137	2715
186	257	40	22	76,2	50,0	7011	5328	20	11	37,4	24,4	3183	2729
188	256	40	22	75,6	50,0	7108	5359	20	11	37,1	24,4	3230	2743
190	255	40	22	75,0	50,0	7206	5390	20	11	36,8	24,4	3278	2757
192	254	40	22	74,4	50,0	7305	5422	20	11	36,5	24,4	3325	2771
194	253	40	22	73,8	50,0	7405	5453	20	11	36,2	24,4	3374	2786
196	252	40	22	73,3	50,0	7505	5485	20	11	35,9	24,4	3422	2800
198	251	40	22	72,7	50,0	7607	5516	20	11	35,6	24,4	3471	2815
200	250	40	22	72,1	50,0	7709	5548	20	11	35,3	24,4	3521	2829
202	249	40	22	71,5	50,0	7812	5580	20	11	35,0	24,4	3571	2844
204	248	40	22	70,9	50,0	7916	5612	20	11	34,7	24,4	3621	2859
206	247	40	22	70,3	50,0	8021	5644	20	11	34,4	24,4	3672	2874
208	246	40	22	69,7	50,0	8127	5677	20	11	34,1	24,4	3724	2889
210	245	40	22	69,1	50,0	8233	5709	20	11	33,9	24,4	3775	2904
212	244	40	22	68,6	50,0	8341	5742	20	11	33,6	24,4	3828	2919
214	243	40	22	68,0	50,0	8449	5774	20	11	33,3	24,4	3880	2935
216	242	40	22	67,4	50,0	8558	5807	20	11	33,0	24,4	3933	2950
218	241	40	22	66,8	50,0	8668	5840	20	11	32,7	24,4	3987	2965
220	240	40	22	66,3	50,0	8779	5873	20	11	32,4	24,4	4041	2981

Table B46: Joist hanger Blank 740 (220 x 260): Form factors k<sub>H,1</sub> and k<sub>H,2</sub> and dimensions e<sub>1</sub> and e<sub>2</sub>; e<sub>J,0</sub> = 52 mm

B [mm]	H [mm]	full nailing						partial nailing					
		n <sub>H</sub>	n <sub>J</sub>	k <sub>H,1</sub>	k <sub>H,2</sub>	e <sub>1</sub> [mm]	e <sub>2</sub> [mm]	n <sub>H</sub>	n <sub>J</sub>	k <sub>H,1</sub>	k <sub>H,2</sub>	e <sub>1</sub> [mm]	e <sub>2</sub> [mm]
51	345	44	24	136	60,6	2674	4883	22	12	67,3	29,6	1189	3172
60	340	44	24	133	60,6	2862	4846	22	12	65,6	29,6	1268	3019
62	339	44	24	132	60,6	2906	4843	22	12	65,3	29,6	1287	2993
64	338	44	24	131	60,6	2951	4841	22	12	64,9	29,6	1306	2968
66	337	44	24	131	60,6	2996	4840	22	12	64,6	29,6	1326	2946
68	336	44	24	130	60,6	3043	4841	22	12	64,2	29,6	1346	2925
70	335	44	24	129	60,6	3090	4843	22	12	63,8	29,6	1366	2906
72	334	44	24	129	60,6	3138	4846	22	12	63,5	29,6	1387	2889
73	334	44	24	128	60,6	3163	4848	22	12	63,3	29,6	1397	2881
74	333	44	24	128	60,6	3187	4850	22	12	63,1	29,6	1408	2874
76	332	44	24	127	60,6	3237	4856	22	12	62,8	29,6	1430	2860
78	331	44	24	126	60,6	3288	4862	22	12	62,4	29,6	1452	2847
80	330	44	24	126	60,6	3339	4870	22	12	62,1	29,6	1475	2836
82	329	44	24	125	60,6	3392	4879	22	12	61,7	29,6	1498	2826
84	328	44	24	124	60,6	3445	4888	22	12	61,3	29,6	1522	2818
86	327	44	24	124	60,6	3499	4899	22	12	61,0	29,6	1546	2810
88	326	44	24	123	60,6	3554	4910	22	12	60,6	29,6	1570	2803
90	325	44	24	122	60,6	3610	4922	22	12	60,3	29,6	1595	2798

B [mm]	H [mm]	full nailing						partial nailing					
		n <sub>H</sub>	n <sub>J</sub>	k <sub>H,1</sub>	k <sub>H,2</sub>	e <sub>1</sub> [mm]	e <sub>2</sub> [mm]	n <sub>H</sub>	n <sub>J</sub>	k <sub>H,1</sub>	k <sub>H,2</sub>	e <sub>1</sub> [mm]	e <sub>2</sub> [mm]
92	324	44	24	121	60,6	3666	4935	22	12	59,9	29,6	1620	2793
94	323	44	24	121	60,6	3724	4949	22	12	59,6	29,6	1646	2790
96	322	44	24	120	60,6	3782	4964	22	12	59,2	29,6	1672	2787
98	321	44	24	119	60,6	3841	4979	22	12	58,9	29,6	1699	2785
100	320	44	24	119	60,6	3901	4995	22	12	58,5	29,6	1726	2783
102	319	44	24	118	60,6	3962	5012	22	12	58,1	29,6	1753	2783
104	318	44	24	117	60,6	4023	5029	22	12	57,8	29,6	1781	2783
106	317	44	24	116	60,6	4086	5047	22	12	57,4	29,6	1810	2784
108	316	44	24	116	60,6	4149	5066	22	12	57,1	29,6	1838	2785
110	315	44	24	115	60,6	4213	5085	22	12	56,7	29,6	1868	2787
112	314	44	24	114	60,6	4278	5105	22	12	56,4	29,6	1897	2790
114	313	44	24	114	60,6	4344	5125	22	12	56,0	29,6	1927	2793
116	312	44	24	113	60,6	4410	5146	22	12	55,7	29,6	1958	2797
118	311	44	24	112	60,6	4478	5167	22	12	55,3	29,6	1989	2801
120	310	44	24	112	60,6	4546	5189	22	12	55,0	29,6	2020	2806
122	309	44	24	111	60,6	4615	5211	22	12	54,7	29,6	2052	2811
124	308	44	24	110	60,6	4685	5234	22	12	54,3	29,6	2085	2817
126	307	44	24	110	60,6	4756	5257	22	12	54,0	29,6	2118	2823
128	306	44	24	109	60,6	4828	5280	22	12	53,6	29,6	2151	2830
130	305	44	24	108	60,6	4900	5304	22	12	53,3	29,6	2184	2837
132	304	44	24	107	60,6	4974	5329	22	12	52,9	29,6	2218	2844
134	303	44	24	107	60,6	5048	5354	22	12	52,6	29,6	2253	2852
136	302	44	24	106	60,6	5123	5379	22	12	52,2	29,6	2288	2860
138	301	44	24	105	60,6	5199	5405	22	12	51,9	29,6	2323	2868
140	300	44	24	105	60,6	5275	5431	22	12	51,6	29,6	2359	2877
142	299	44	24	104	60,6	5353	5457	22	12	51,2	29,6	2396	2886
144	298	44	24	103	60,6	5431	5484	22	12	50,9	29,6	2432	2896
146	297	44	24	103	60,6	5510	5510	22	12	50,5	29,6	2470	2905
148	296	44	24	102	60,6	5591	5538	22	12	50,2	29,6	2507	2915
150	295	44	24	101	60,6	5671	5565	22	12	49,9	29,6	2545	2925
152	294	44	24	101	60,6	5753	5593	22	12	49,5	29,6	2584	2936
154	293	44	24	100	60,6	5836	5622	22	12	49,2	29,6	2623	2947
156	292	44	24	99,3	60,6	5919	5650	22	12	48,8	29,6	2662	2958
158	291	44	24	98,6	60,6	6003	5679	22	12	48,5	29,6	2702	2969
160	290	44	24	97,9	60,6	6088	5708	22	12	48,2	29,6	2742	2981
162	289	44	24	97,3	60,6	6174	5737	22	12	47,8	29,6	2783	2992
164	288	44	24	96,6	60,6	6261	5767	22	12	47,5	29,6	2824	3004
166	287	44	24	95,9	60,6	6349	5797	22	12	47,2	29,6	2866	3016
168	286	44	24	95,3	60,6	6437	5827	22	12	46,8	29,6	2908	3029
170	285	44	24	94,6	60,6	6526	5857	22	12	46,5	29,6	2950	3041
172	284	44	24	93,9	60,6	6616	5887	22	12	46,2	29,6	2993	3054
174	283	44	24	93,3	60,6	6707	5918	22	12	45,8	29,6	3036	3067
176	282	44	24	92,6	60,6	6799	5949	22	12	45,5	29,6	3080	3080
178	281	44	24	91,9	60,6	6892	5980	22	12	45,2	29,6	3124	3093
180	280	44	24	91,3	60,6	6985	6012	22	12	44,8	29,6	3169	3107
182	279	44	24	90,6	60,6	7079	6043	22	12	44,5	29,6	3214	3120
184	278	44	24	90,0	60,6	7175	6075	22	12	44,2	29,6	3260	3134
186	277	44	24	89,3	60,6	7270	6107	22	12	43,9	29,6	3306	3148
188	276	44	24	88,7	60,6	7367	6139	22	12	43,5	29,6	3352	3162
190	275	44	24	88,0	60,6	7465	6172	22	12	43,2	29,6	3399	3176
192	274	44	24	87,4	60,6	7563	6204	22	12	42,9	29,6	3446	3191
194	273	44	24	86,7	60,6	7663	6237	22	12	42,6	29,6	3494	3205

B [mm]	H [mm]	full nailing						partial nailing					
		n <sub>H</sub>	n <sub>J</sub>	k <sub>H,1</sub>	k <sub>H,2</sub>	e <sub>1</sub> [mm]	e <sub>2</sub> [mm]	n <sub>H</sub>	n <sub>J</sub>	k <sub>H,1</sub>	k <sub>H,2</sub>	e <sub>1</sub> [mm]	e <sub>2</sub> [mm]
196	272	44	24	86,1	60,6	7763	6270	22	12	42,2	29,6	3542	3220
198	271	44	24	85,4	60,6	7864	6303	22	12	41,9	29,6	3591	3235
200	270	44	24	84,8	60,6	7966	6336	22	12	41,6	29,6	3640	3250
202	269	44	24	84,1	60,6	8068	6370	22	12	41,3	29,6	3689	3265
204	268	44	24	83,5	60,6	8172	6403	22	12	41,0	29,6	3739	3280
206	267	44	24	82,9	60,6	8276	6437	22	12	40,6	29,6	3790	3295
208	266	44	24	82,2	60,6	8381	6471	22	12	40,3	29,6	3840	3311
210	265	44	24	81,6	60,6	8487	6505	22	12	40,0	29,6	3892	3326
212	264	44	24	81,0	60,6	8594	6539	22	12	39,7	29,6	3943	3342
214	263	44	24	80,3	60,6	8702	6573	22	12	39,4	29,6	3995	3357
216	262	44	24	79,7	60,6	8810	6608	22	12	39,1	29,6	4048	3373
218	261	44	24	79,1	60,6	8920	6642	22	12	38,8	29,6	4101	3389
220	260	44	24	78,4	60,6	9030	6677	22	12	38,4	29,6	4154	3405

Table B47: Joist hanger Blank 780 (220 x 280): Form factors k<sub>H,1</sub> and k<sub>H,2</sub> and dimensions e<sub>1</sub> and e<sub>2</sub>; e<sub>J,0</sub> = 52 mm

B [mm]	H [mm]	full nailing						partial nailing					
		n <sub>H</sub>	n <sub>J</sub>	k <sub>H,1</sub>	k <sub>H,2</sub>	e <sub>1</sub> [mm]	e <sub>2</sub> [mm]	n <sub>H</sub>	n <sub>J</sub>	k <sub>H,1</sub>	k <sub>H,2</sub>	e <sub>1</sub> [mm]	e <sub>2</sub> [mm]
51	365	48	26	154	72,3	2983	5967	24	13	76,1	35,4	1347	3951
60	360	48	26	150	72,3	3170	5881	24	13	74,4	35,4	1425	3732
62	359	48	26	150	72,3	3214	5867	24	13	74,0	35,4	1443	3692
64	358	48	26	149	72,3	3259	5856	24	13	73,6	35,4	1462	3656
66	357	48	26	148	72,3	3304	5846	24	13	73,2	35,4	1482	3622
68	356	48	26	147	72,3	3351	5838	24	13	72,8	35,4	1502	3591
70	355	48	26	147	72,3	3398	5832	24	13	72,4	35,4	1522	3562
72	354	48	26	146	72,3	3446	5828	24	13	72,0	35,4	1543	3535
73	354	48	26	145	72,3	3470	5826	24	13	71,8	35,4	1553	3523
74	353	48	26	145	72,3	3495	5824	24	13	71,6	35,4	1564	3511
76	352	48	26	144	72,3	3544	5823	24	13	71,3	35,4	1585	3488
78	351	48	26	143	72,3	3595	5823	24	13	70,9	35,4	1607	3467
80	350	48	26	143	72,3	3646	5824	24	13	70,5	35,4	1630	3448
82	349	48	26	142	72,3	3698	5826	24	13	70,1	35,4	1653	3430
84	348	48	26	141	72,3	3751	5830	24	13	69,7	35,4	1676	3415
86	347	48	26	140	72,3	3805	5835	24	13	69,3	35,4	1700	3400
88	346	48	26	140	72,3	3860	5841	24	13	68,9	35,4	1724	3387
90	345	48	26	139	72,3	3915	5848	24	13	68,6	35,4	1749	3375
92	344	48	26	138	72,3	3972	5856	24	13	68,2	35,4	1774	3364
94	343	48	26	137	72,3	4029	5865	24	13	67,8	35,4	1799	3355
96	342	48	26	137	72,3	4087	5875	24	13	67,4	35,4	1825	3347
98	341	48	26	136	72,3	4146	5886	24	13	67,0	35,4	1852	3339
100	340	48	26	135	72,3	4205	5898	24	13	66,7	35,4	1879	3333
102	339	48	26	134	72,3	4266	5911	24	13	66,3	35,4	1906	3328
104	338	48	26	134	72,3	4327	5924	24	13	65,9	35,4	1934	3324
106	337	48	26	133	72,3	4390	5939	24	13	65,5	35,4	1962	3320
108	336	48	26	132	72,3	4453	5954	24	13	65,1	35,4	1990	3317
110	335	48	26	131	72,3	4516	5970	24	13	64,8	35,4	2019	3315
112	334	48	26	131	72,3	4581	5987	24	13	64,4	35,4	2049	3314
114	333	48	26	130	72,3	4647	6004	24	13	64,0	35,4	2079	3314
116	332	48	26	129	72,3	4713	6022	24	13	63,6	35,4	2109	3314
118	331	48	26	128	72,3	4780	6041	24	13	63,2	35,4	2140	3315
120	330	48	26	127	72,3	4848	6060	24	13	62,9	35,4	2171	3317
122	329	48	26	127	72,3	4917	6080	24	13	62,5	35,4	2203	3319

B [mm]	H [mm]	full nailing						partial nailing					
		n <sub>H</sub>	n <sub>J</sub>	k <sub>H,1</sub>	k <sub>H,2</sub>	e <sub>1</sub> [mm]	e <sub>2</sub> [mm]	n <sub>H</sub>	n <sub>J</sub>	k <sub>H,1</sub>	k <sub>H,2</sub>	e <sub>1</sub> [mm]	e <sub>2</sub> [mm]
124	328	48	26	126	72,3	4987	6101	24	13	62,1	35,4	2235	3322
126	327	48	26	125	72,3	5057	6122	24	13	61,7	35,4	2267	3325
128	326	48	26	125	72,3	5129	6144	24	13	61,4	35,4	2300	3329
130	325	48	26	124	72,3	5201	6166	24	13	61,0	35,4	2334	3334
132	324	48	26	123	72,3	5274	6189	24	13	60,6	35,4	2367	3339
134	323	48	26	122	72,3	5348	6212	24	13	60,3	35,4	2402	3344
136	322	48	26	122	72,3	5423	6236	24	13	59,9	35,4	2436	3350
138	321	48	26	121	72,3	5498	6260	24	13	59,5	35,4	2471	3356
140	320	48	26	120	72,3	5575	6285	24	13	59,2	35,4	2507	3363
142	319	48	26	119	72,3	5652	6310	24	13	58,8	35,4	2543	3370
144	318	48	26	119	72,3	5730	6336	24	13	58,4	35,4	2579	3378
146	317	48	26	118	72,3	5809	6362	24	13	58,0	35,4	2616	3386
148	316	48	26	117	72,3	5888	6388	24	13	57,7	35,4	2654	3394
150	315	48	26	116	72,3	5969	6415	24	13	57,3	35,4	2691	3403
152	314	48	26	116	72,3	6050	6443	24	13	56,9	35,4	2730	3412
154	313	48	26	115	72,3	6133	6470	24	13	56,6	35,4	2768	3421
156	312	48	26	114	72,3	6216	6498	24	13	56,2	35,4	2807	3431
158	311	48	26	113	72,3	6300	6527	24	13	55,9	35,4	2847	3441
160	310	48	26	113	72,3	6384	6555	24	13	55,5	35,4	2887	3451
162	309	48	26	112	72,3	6470	6584	24	13	55,1	35,4	2927	3462
164	308	48	26	111	72,3	6556	6614	24	13	54,8	35,4	2968	3473
166	307	48	26	111	72,3	6643	6643	24	13	54,4	35,4	3009	3484
168	306	48	26	110	72,3	6732	6674	24	13	54,1	35,4	3051	3496
170	305	48	26	109	72,3	6820	6704	24	13	53,7	35,4	3093	3507
172	304	48	26	108	72,3	6910	6735	24	13	53,3	35,4	3135	3519
174	303	48	26	108	72,3	7001	6765	24	13	53,0	35,4	3178	3532
176	302	48	26	107	72,3	7092	6797	24	13	52,6	35,4	3222	3544
178	301	48	26	106	72,3	7184	6828	24	13	52,3	35,4	3266	3557
180	300	48	26	106	72,3	7277	6860	24	13	51,9	35,4	3310	3570
182	299	48	26	105	72,3	7371	6892	24	13	51,6	35,4	3355	3583
184	298	48	26	104	72,3	7466	6924	24	13	51,2	35,4	3400	3596
186	297	48	26	103	72,3	7562	6957	24	13	50,8	35,4	3445	3610
188	296	48	26	103	72,3	7658	6990	24	13	50,5	35,4	3491	3623
190	295	48	26	102	72,3	7755	7023	24	13	50,1	35,4	3538	3637
192	294	48	26	101	72,3	7853	7056	24	13	49,8	35,4	3585	3651
194	293	48	26	101	72,3	7952	7089	24	13	49,4	35,4	3632	3666
196	292	48	26	99,9	72,3	8052	7123	24	13	49,1	35,4	3680	3680
198	291	48	26	99,2	72,3	8153	7157	24	13	48,7	35,4	3728	3695
200	290	48	26	98,5	72,3	8254	7191	24	13	48,4	35,4	3777	3709
202	289	48	26	97,8	72,3	8356	7226	24	13	48,1	35,4	3826	3724
204	288	48	26	97,1	72,3	8460	7260	24	13	47,7	35,4	3875	3740
206	287	48	26	96,4	72,3	8563	7295	24	13	47,4	35,4	3925	3755
208	286	48	26	95,8	72,3	8668	7330	24	13	47,0	35,4	3976	3770
210	285	48	26	95,1	72,3	8774	7365	24	13	46,7	35,4	4027	3786
212	284	48	26	94,4	72,3	8880	7400	24	13	46,3	35,4	4078	3801
214	283	48	26	93,7	72,3	8988	7436	24	13	46,0	35,4	4130	3817
216	282	48	26	93,0	72,3	9096	7471	24	13	45,7	35,4	4182	3833
218	281	48	26	92,3	72,3	9205	7507	24	13	45,3	35,4	4234	3849
220	280	48	26	91,7	72,3	9314	7543	24	13	45,0	35,4	4287	3866

Table B48: Joist hanger Blank 820 (220 x 300): Form factors  $k_{H,1}$  and  $k_{H,2}$  and dimensions  $e_1$  and  $e_2$ ;  $e_{J,0} = 52$  mm

B [mm]	H [mm]	full nailing						partial nailing					
		$n_H$	$n_J$	$k_{H,1}$	$k_{H,2}$	$e_1$ [mm]	$e_2$ [mm]	$n_H$	$n_J$	$k_{H,1}$	$k_{H,2}$	$e_1$ [mm]	$e_2$ [mm]
51	385	52	28	173	85,0	3320	7218	26	14	85,5	41,7	1518	4858
60	380	52	28	169	85,0	3506	7069	26	14	83,6	41,7	1596	4559
62	379	52	28	168	85,0	3550	7044	26	14	83,2	41,7	1614	4504
64	378	52	28	167	85,0	3595	7021	26	14	82,7	41,7	1633	4453
66	377	52	28	167	85,0	3640	7000	26	14	82,3	41,7	1652	4406
68	376	52	28	166	85,0	3686	6981	26	14	81,9	41,7	1672	4361
70	375	52	28	165	85,0	3733	6965	26	14	81,5	41,7	1692	4320
72	374	52	28	164	85,0	3781	6950	26	14	81,1	41,7	1713	4281
73	374	52	28	164	85,0	3805	6944	26	14	80,9	41,7	1723	4263
74	373	52	28	163	85,0	3830	6938	26	14	80,7	41,7	1734	4245
76	372	52	28	162	85,0	3879	6927	26	14	80,2	41,7	1755	4212
78	371	52	28	162	85,0	3930	6918	26	14	79,8	41,7	1777	4181
80	370	52	28	161	85,0	3981	6911	26	14	79,4	41,7	1799	4152
82	369	52	28	160	85,0	4033	6905	26	14	79,0	41,7	1822	4125
84	368	52	28	159	85,0	4086	6901	26	14	78,6	41,7	1845	4100
86	367	52	28	158	85,0	4139	6899	26	14	78,2	41,7	1869	4077
88	366	52	28	157	85,0	4194	6898	26	14	77,8	41,7	1893	4056
90	365	52	28	157	85,0	4249	6898	26	14	77,4	41,7	1917	4036
92	364	52	28	156	85,0	4305	6899	26	14	76,9	41,7	1942	4018
94	363	52	28	155	85,0	4362	6902	26	14	76,5	41,7	1968	4002
96	362	52	28	154	85,0	4420	6906	26	14	76,1	41,7	1993	3987
98	361	52	28	153	85,0	4479	6912	26	14	75,7	41,7	2020	3973
100	360	52	28	153	85,0	4538	6918	26	14	75,3	41,7	2046	3960
102	359	52	28	152	85,0	4598	6925	26	14	74,9	41,7	2073	3949
104	358	52	28	151	85,0	4660	6934	26	14	74,5	41,7	2101	3939
106	357	52	28	150	85,0	4722	6944	26	14	74,1	41,7	2129	3930
108	356	52	28	149	85,0	4784	6954	26	14	73,7	41,7	2157	3922
110	355	52	28	148	85,0	4848	6966	26	14	73,3	41,7	2186	3915
112	354	52	28	148	85,0	4913	6978	26	14	72,9	41,7	2215	3909
114	353	52	28	147	85,0	4978	6991	26	14	72,5	41,7	2245	3904
116	352	52	28	146	85,0	5044	7006	26	14	72,1	41,7	2275	3900
118	351	52	28	145	85,0	5111	7021	26	14	71,7	41,7	2306	3897
120	350	52	28	144	85,0	5179	7036	26	14	71,3	41,7	2337	3894
122	349	52	28	144	85,0	5247	7053	26	14	70,8	41,7	2368	3893
124	348	52	28	143	85,0	5317	7070	26	14	70,4	41,7	2400	3892
126	347	52	28	142	85,0	5387	7088	26	14	70,0	41,7	2432	3891
128	346	52	28	141	85,0	5458	7107	26	14	69,6	41,7	2465	3892
130	345	52	28	140	85,0	5530	7127	26	14	69,2	41,7	2498	3893
132	344	52	28	140	85,0	5603	7147	26	14	68,8	41,7	2532	3895
134	343	52	28	139	85,0	5677	7168	26	14	68,4	41,7	2566	3897
136	342	52	28	138	85,0	5751	7189	26	14	68,1	41,7	2600	3900
138	341	52	28	137	85,0	5826	7211	26	14	67,7	41,7	2635	3904
140	340	52	28	136	85,0	5903	7234	26	14	67,3	41,7	2670	3908
142	339	52	28	136	85,0	5980	7257	26	14	66,9	41,7	2706	3912
144	338	52	28	135	85,0	6057	7281	26	14	66,5	41,7	2742	3917
146	337	52	28	134	85,0	6136	7305	26	14	66,1	41,7	2779	3923
148	336	52	28	133	85,0	6215	7330	26	14	65,7	41,7	2816	3929
150	335	52	28	132	85,0	6296	7355	26	14	65,3	41,7	2853	3936
152	334	52	28	132	85,0	6377	7381	26	14	64,9	41,7	2891	3943
154	333	52	28	131	85,0	6459	7407	26	14	64,5	41,7	2930	3950
156	332	52	28	130	85,0	6542	7434	26	14	64,1	41,7	2968	3958

B [mm]	H [mm]	full nailing						partial nailing					
		n <sub>H</sub>	n <sub>J</sub>	k <sub>H,1</sub>	k <sub>H,2</sub>	e <sub>1</sub> [mm]	e <sub>2</sub> [mm]	n <sub>H</sub>	n <sub>J</sub>	k <sub>H,1</sub>	k <sub>H,2</sub>	e <sub>1</sub> [mm]	e <sub>2</sub> [mm]
158	331	52	28	129	85,0	6625	7461	26	14	63,7	41,7	3008	3966
160	330	52	28	129	85,0	6710	7488	26	14	63,3	41,7	3047	3975
162	329	52	28	128	85,0	6795	7517	26	14	62,9	41,7	3087	3984
164	328	52	28	127	85,0	6881	7545	26	14	62,6	41,7	3128	3993
166	327	52	28	126	85,0	6968	7574	26	14	62,2	41,7	3169	4003
168	326	52	28	125	85,0	7056	7603	26	14	61,8	41,7	3210	4013
170	325	52	28	125	85,0	7144	7633	26	14	61,4	41,7	3252	4023
172	324	52	28	124	85,0	7234	7663	26	14	61,0	41,7	3294	4034
174	323	52	28	123	85,0	7324	7693	26	14	60,6	41,7	3337	4045
176	322	52	28	122	85,0	7415	7724	26	14	60,2	41,7	3380	4056
178	321	52	28	122	85,0	7507	7755	26	14	59,9	41,7	3424	4068
180	320	52	28	121	85,0	7600	7787	26	14	59,5	41,7	3468	4079
182	319	52	28	120	85,0	7694	7819	26	14	59,1	41,7	3512	4092
184	318	52	28	119	85,0	7788	7851	26	14	58,7	41,7	3557	4104
186	317	52	28	119	85,0	7883	7883	26	14	58,3	41,7	3602	4117
188	316	52	28	118	85,0	7979	7916	26	14	58,0	41,7	3648	4130
190	315	52	28	117	85,0	8076	7949	26	14	57,6	41,7	3694	4143
192	314	52	28	116	85,0	8174	7982	26	14	57,2	41,7	3741	4156
194	313	52	28	116	85,0	8273	8016	26	14	56,8	41,7	3788	4170
196	312	52	28	115	85,0	8372	8050	26	14	56,5	41,7	3835	4184
198	311	52	28	114	85,0	8472	8084	26	14	56,1	41,7	3883	4198
200	310	52	28	113	85,0	8573	8119	26	14	55,7	41,7	3931	4212
202	309	52	28	113	85,0	8675	8153	26	14	55,3	41,7	3980	4226
204	308	52	28	112	85,0	8778	8188	26	14	55,0	41,7	4029	4241
206	307	52	28	111	85,0	8882	8224	26	14	54,6	41,7	4079	4256
208	306	52	28	110	85,0	8986	8259	26	14	54,2	41,7	4129	4271
210	305	52	28	110	85,0	9091	8295	26	14	53,9	41,7	4179	4286
212	304	52	28	109	85,0	9197	8331	26	14	53,5	41,7	4230	4302
214	303	52	28	108	85,0	9304	8367	26	14	53,1	41,7	4282	4318
216	302	52	28	107	85,0	9412	8404	26	14	52,8	41,7	4333	4333
218	301	52	28	107	85,0	9521	8440	26	14	52,4	41,7	4386	4349
220	300	52	28	106	85,0	9630	8477	26	14	52,0	41,7	4438	4365

Table B49: Joist hanger Blank 860 (220 x 320): Form factors k<sub>H,1</sub> and k<sub>H,2</sub> and dimensions e<sub>1</sub> and e<sub>2</sub>; e<sub>1,0</sub> = 52 mm

B [mm]	H [mm]	full nailing						partial nailing					
		n <sub>H</sub>	n <sub>J</sub>	k <sub>H,1</sub>	k <sub>H,2</sub>	e <sub>1</sub> [mm]	e <sub>2</sub> [mm]	n <sub>H</sub>	n <sub>J</sub>	k <sub>H,1</sub>	k <sub>H,2</sub>	e <sub>1</sub> [mm]	e <sub>2</sub> [mm]
51	405	56	30	193	98,7	3684	8650	28	15	95,3	48,5	1703	5903
60	400	56	30	189	98,7	3870	8426	28	15	93,3	48,5	1780	5509
62	399	56	30	188	98,7	3913	8386	28	15	92,8	48,5	1798	5437
64	398	56	30	187	98,7	3958	8348	28	15	92,4	48,5	1817	5368
66	397	56	30	186	98,7	4003	8314	28	15	91,9	48,5	1836	5304
68	396	56	30	185	98,7	4049	8282	28	15	91,5	48,5	1856	5245
70	395	56	30	184	98,7	4096	8253	28	15	91,1	48,5	1876	5188
72	394	56	30	183	98,7	4144	8226	28	15	90,6	48,5	1896	5136
73	394	56	30	183	98,7	4168	8214	28	15	90,4	48,5	1907	5111
74	393	56	30	182	98,7	4192	8202	28	15	90,2	48,5	1917	5086
76	392	56	30	181	98,7	4241	8180	28	15	89,7	48,5	1938	5040
78	391	56	30	181	98,7	4292	8160	28	15	89,3	48,5	1960	4997
80	390	56	30	180	98,7	4343	8143	28	15	88,8	48,5	1982	4956
82	389	56	30	179	98,7	4395	8127	28	15	88,4	48,5	2005	4918
84	388	56	30	178	98,7	4447	8113	28	15	88,0	48,5	2028	4882

B [mm]	H [mm]	full nailing						partial nailing					
		n <sub>H</sub>	n <sub>J</sub>	k <sub>H,1</sub>	k <sub>H,2</sub>	e <sub>1</sub> [mm]	e <sub>2</sub> [mm]	n <sub>H</sub>	n <sub>J</sub>	k <sub>H,1</sub>	k <sub>H,2</sub>	e <sub>1</sub> [mm]	e <sub>2</sub> [mm]
86	387	56	30	177	98,7	4501	8101	28	15	87,5	48,5	2052	4849
88	386	56	30	176	98,7	4555	8091	28	15	87,1	48,5	2075	4818
90	385	56	30	175	98,7	4610	8083	28	15	86,6	48,5	2100	4789
92	384	56	30	174	98,7	4666	8076	28	15	86,2	48,5	2125	4762
94	383	56	30	174	98,7	4723	8071	28	15	85,8	48,5	2150	4737
96	382	56	30	173	98,7	4781	8068	28	15	85,3	48,5	2175	4713
98	381	56	30	172	98,7	4839	8065	28	15	84,9	48,5	2201	4692
100	380	56	30	171	98,7	4899	8065	28	15	84,5	48,5	2228	4671
102	379	56	30	170	98,7	4959	8065	28	15	84,0	48,5	2255	4653
104	378	56	30	169	98,7	5020	8067	28	15	83,6	48,5	2282	4636
106	377	56	30	168	98,7	5081	8071	28	15	83,2	48,5	2310	4620
108	376	56	30	167	98,7	5144	8075	28	15	82,7	48,5	2338	4606
110	375	56	30	167	98,7	5208	8081	28	15	82,3	48,5	2367	4592
112	374	56	30	166	98,7	5272	8088	28	15	81,9	48,5	2396	4580
114	373	56	30	165	98,7	5337	8095	28	15	81,4	48,5	2425	4570
116	372	56	30	164	98,7	5403	8104	28	15	81,0	48,5	2455	4560
118	371	56	30	163	98,7	5470	8114	28	15	80,6	48,5	2486	4551
120	370	56	30	162	98,7	5537	8125	28	15	80,1	48,5	2517	4544
122	369	56	30	161	98,7	5606	8137	28	15	79,7	48,5	2548	4537
124	368	56	30	161	98,7	5675	8150	28	15	79,3	48,5	2579	4531
126	367	56	30	160	98,7	5745	8164	28	15	78,9	48,5	2612	4527
128	366	56	30	159	98,7	5816	8179	28	15	78,4	48,5	2644	4523
130	365	56	30	158	98,7	5888	8194	28	15	78,0	48,5	2677	4520
132	364	56	30	157	98,7	5960	8211	28	15	77,6	48,5	2710	4517
134	363	56	30	156	98,7	6034	8228	28	15	77,1	48,5	2744	4516
136	362	56	30	155	98,7	6108	8246	28	15	76,7	48,5	2778	4515
138	361	56	30	155	98,7	6183	8265	28	15	76,3	48,5	2813	4515
140	360	56	30	154	98,7	6259	8284	28	15	75,9	48,5	2848	4516
142	359	56	30	153	98,7	6336	8304	28	15	75,5	48,5	2884	4517
144	358	56	30	152	98,7	6413	8325	28	15	75,0	48,5	2920	4519
146	357	56	30	151	98,7	6492	8347	28	15	74,6	48,5	2956	4521
148	356	56	30	150	98,7	6571	8369	28	15	74,2	48,5	2993	4524
150	355	56	30	150	98,7	6651	8392	28	15	73,8	48,5	3030	4528
152	354	56	30	149	98,7	6732	8415	28	15	73,4	48,5	3068	4532
154	353	56	30	148	98,7	6814	8439	28	15	72,9	48,5	3106	4537
156	352	56	30	147	98,7	6896	8464	28	15	72,5	48,5	3145	4542
158	351	56	30	146	98,7	6980	8489	28	15	72,1	48,5	3184	4548
160	350	56	30	145	98,7	7064	8515	28	15	71,7	48,5	3223	4554
162	349	56	30	145	98,7	7149	8541	28	15	71,3	48,5	3263	4561
164	348	56	30	144	98,7	7235	8568	28	15	70,9	48,5	3303	4568
166	347	56	30	143	98,7	7321	8595	28	15	70,4	48,5	3344	4576
168	346	56	30	142	98,7	7409	8623	28	15	70,0	48,5	3385	4584
170	345	56	30	141	98,7	7497	8651	28	15	69,6	48,5	3427	4592
172	344	56	30	140	98,7	7587	8680	28	15	69,2	48,5	3469	4601
174	343	56	30	140	98,7	7677	8709	28	15	68,8	48,5	3511	4610
176	342	56	30	139	98,7	7767	8738	28	15	68,4	48,5	3554	4620
178	341	56	30	138	98,7	7859	8768	28	15	68,0	48,5	3597	4630
180	340	56	30	137	98,7	7952	8799	28	15	67,6	48,5	3641	4640
182	339	56	30	136	98,7	8045	8830	28	15	67,2	48,5	3685	4651
184	338	56	30	136	98,7	8139	8861	28	15	66,8	48,5	3730	4662
186	337	56	30	135	98,7	8234	8893	28	15	66,4	48,5	3775	4673
188	336	56	30	134	98,7	8330	8925	28	15	65,9	48,5	3820	4685

B [mm]	H [mm]	full nailing						partial nailing					
		n <sub>H</sub>	n <sub>J</sub>	k <sub>H,1</sub>	k <sub>H,2</sub>	e <sub>1</sub> [mm]	e <sub>2</sub> [mm]	n <sub>H</sub>	n <sub>J</sub>	k <sub>H,1</sub>	k <sub>H,2</sub>	e <sub>1</sub> [mm]	e <sub>2</sub> [mm]
190	335	56	30	133	98,7	8427	8957	28	15	65,5	48,5	3866	4697
192	334	56	30	132	98,7	8524	8990	28	15	65,1	48,5	3912	4709
194	333	56	30	131	98,7	8622	9023	28	15	64,7	48,5	3959	4722
196	332	56	30	131	98,7	8721	9057	28	15	64,3	48,5	4006	4735
198	331	56	30	130	98,7	8821	9091	28	15	63,9	48,5	4054	4748
200	330	56	30	129	98,7	8922	9125	28	15	63,5	48,5	4102	4761
202	329	56	30	128	98,7	9024	9160	28	15	63,1	48,5	4150	4775
204	328	56	30	127	98,7	9126	9194	28	15	62,7	48,5	4199	4788
206	327	56	30	127	98,7	9230	9230	28	15	62,3	48,5	4248	4803
208	326	56	30	126	98,7	9334	9265	28	15	62,0	48,5	4298	4817
210	325	56	30	125	98,7	9439	9301	28	15	61,6	48,5	4348	4832
212	324	56	30	124	98,7	9544	9337	28	15	61,2	48,5	4399	4846
214	323	56	30	124	98,7	9651	9373	28	15	60,8	48,5	4450	4861
216	322	56	30	123	98,7	9759	9410	28	15	60,4	48,5	4502	4877
218	321	56	30	122	98,7	9867	9447	28	15	60,0	48,5	4553	4892
220	320	56	30	121	98,7	9976	9484	28	15	59,6	48,5	4606	4908



## B.2 Characteristic load-carrying-capacities of the joist hanger connections with bolts

For joist hangers connected to a wall of concrete, lightweight concrete or to a steel member the assumptions for the calculation of the load-carrying capacity of the connection are:

- The force transfer from the joist to the joist hanger is as for a wood-wood connection, see clause B.1.
- The bolts shall always be positioned symmetrically about the vertical axis of the joist hanger.
- Washers according to EN ISO 7094 shall be installed under the bolt heads or nuts.

### Description of the static model

For a downward directed force toward the bottom plate the static behaviour is basically the same as for a wood-wood connection with nails.

The fasteners in the joist are subjected to a lateral force, which is equally distributed over the nails in the joist.

Since the concrete and steel have a larger compressive strength than timber subjected perpendicular to the grain the rotation point may be assumed positioned at the top of the bottom plate.

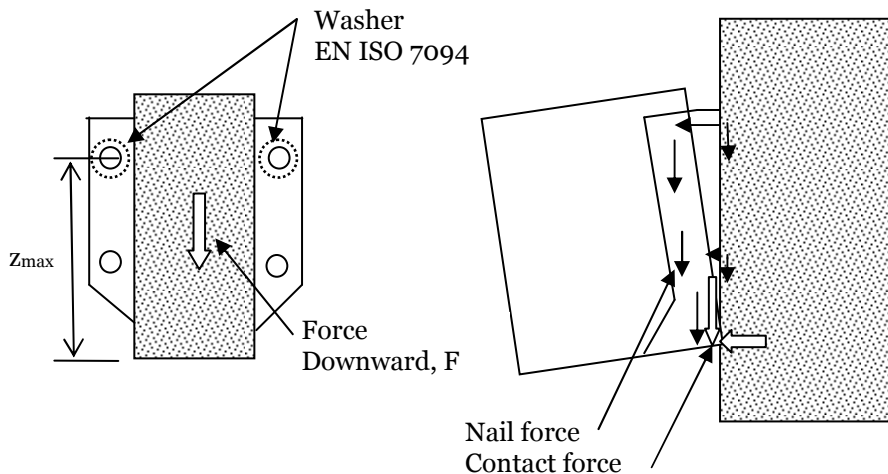

Figure B2 Left: Cross section in joist. Right: The joist will deflect and rotate, at the bottom a contact force will occur at the bottom plate, and the withdrawal forces in the bolts in the wall will vary linearly as assumed for a nailed connection in the header.

The forces in the bolts will be partly lateral forces, partly withdrawal forces. The lateral forces are distributed evenly over all bolts. The withdrawal forces are on the safe side assumed to be taken by the 2 upper bolts with washers. The maximum withdrawal force in a upper bolt can be calculated from

$$F_{\text{ax,bolt}} = \frac{F \cdot e}{2 \cdot z_{\text{max}}} \quad (\text{B.2.1})$$

Where

$F$  downward directed force toward the bottom plate

$e$  eccentricity = distance from the nail column in the joist to the surface of the header.

$z_{\text{max}}$  max distance from upper bolt to the bottom plate (rotation point)

The upper 2 bolts are critical. They are subjected to a lateral force and a withdrawal force. The lateral force is determined assuming an even distribution of the downward force  $F$ .

$$F_{\text{lat,bolt}} = F_{Z,\text{Ed}} / n_{\text{bolt}} \quad (\text{B.2.2})$$

### Characteristic capacities of a bolted joist hanger connection

The characteristic capacity of the nail connection between the joist and the joist hanger can be calculated from the same assumptions and formulas as for joist hangers nailed to a wooden header.

$$F_{Z,J,Rk} = (n_J + 2) \cdot F_{v,J,Rk} \quad (\text{B.2.3})$$

The upper 2 bolts are critical. They are subjected to a lateral force calculated from formula (B.2.2).

The withdrawal force in an upper bolt is calculated from (B.2.1).

Where

$F_{Z,\text{Ed}}$  downward directed force toward the bottom plate

$n_{\text{bolt}}$  total number of bolts in the joist hanger

$e$  eccentricity = distance from the nail column in the joist to the surface of the header

$z_{\text{max}}$  max distance from the upper bolt to the bottom plate (rotation point)

It shall be verified by the design of the bolted connection that the upper bolts have sufficient load-carrying design capacity to carry the combined lateral and axial forces.

From the characteristic capacity of the bearing resistance between the bolt and the plate of the joist hanger the following maximum characteristic capacity of the joist hanger connection can be determined.

$$F_{\text{bear,Rk}} = n_{\text{bolt}} \cdot f_{u,k} \cdot d \cdot t \quad (\text{B.2.4})$$

Where

$n_{\text{bolt}}$  total number of bolts in the 2 flaps

$f_{u,k}$  characteristic ultimate tensile strength of the steel, 360 MPa or 390 MPa

$d$  diameter of the bolt

$t$  thickness of the steel plate of the joist hanger

The characteristic load-carrying capacity of the joist hanger connection is the minimum of:

- The capacity determined from (B.2.3) from the nails in the joist
- The capacity determined from (B.2.4) from the embedding strength of the steel plate against the bolt
- The capacity controlled by the bolt forces given by (B.2.1) and (B.2.2).

**Annex C**  
**Installation of joist hangers**

**Joist hanger in wood/wood connection**

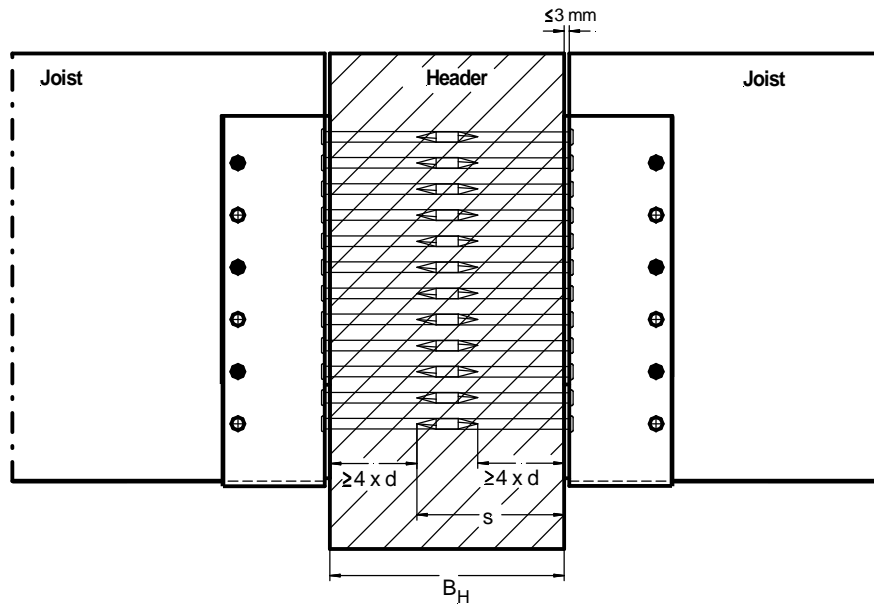
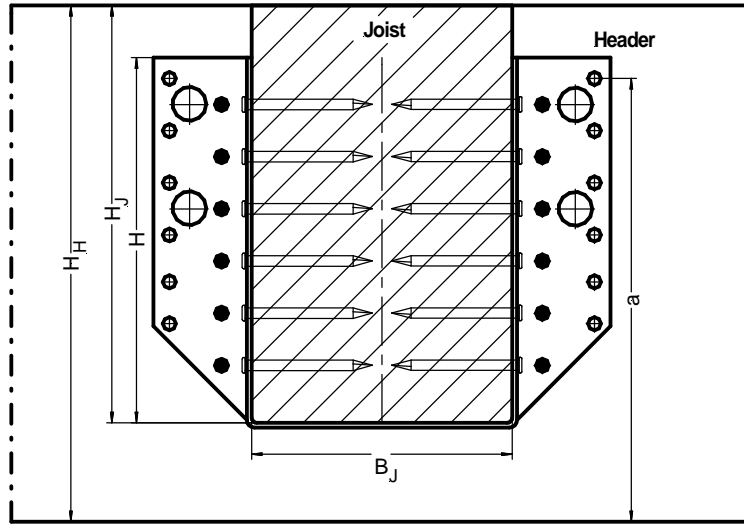

**Joist hanger connected to concrete, lightweight concrete  
or a steel member by bolts**

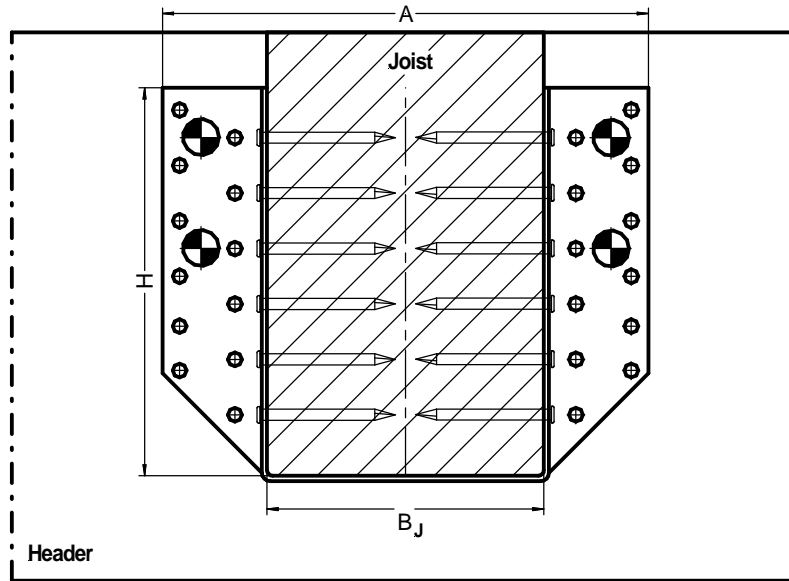

Bolts M10 or M12  
Washer according to  
EN ISO 7094

