

Manual

10", 12" Sliding Panel Saw



For your safety, please read this manual carefully before operation

CONTENT

SPECIFICATIONS	1	Install the hold down	11
SAFETY	2	Install the dust port	12
Safety Instructions for Power Tools	2	Install the blade guard	12
Additional Safety Instructions for Panel Saws	3	Install the dust hose support	12
Protecting Kickback	3	Install dust hoses	12
SITE CONSIDERATIONS	4	REPLACEMENT & ADJUSTMENT	13
GETTING TO KNOW YOUR PANEL SAW	5	Replace the main blade	13
UNPACKING	7	Replace and adjusting the scoring blade	14
Piece Inventory	7	Replace and adjust the riving knives	14
Clean Up	7	Replace the main belt	14
ASSEMBLY	8	Replace the scoring belt	15
Moving & Placing Saw Base Unit	8	Sliding Table Parallel Adjustment	15
Install the extension table	8	OPERATIONS	16
Install the support leg	9	Rip Cutting	16
Install the rip fence rail	9	Crosscutting	16
Install the rear support rail	9	Miter Cutting	18
Install the rear extension table	9	MAINTENANCE	19
Install the main blade elevation & angle handwheel	9	ELECTRICAL	19
Fitting the rip fence and align the rail	10	Main switch	19
Install the swing arm assembly	10	Limit switch	19
Install the Sliding panel assembly	10	Thermo cut-out	19
Adjust the sliding panel level	11	Wiring Diagram	20
Install the cross cut table	11	TROUBLESHOOTING	21
Install the cross cut fence	11	PARTS LIST & DIAGRAMS	22

SPECIFICATIONS

Model	PS10	PS12
Motor power	230V~, 50Hz, 2200 W 400V, 3~, 50Hz, 3000 W	230V~, 50Hz, 3000 W 400V, 3~, 50Hz, 3800 W
Major table size	345x800 mm	385x800 mm
Extension table (Cast iron)	440x800 mm	440x800 mm
Extension table (Steel plate)	480x800 mm	440x800 mm
Rear extension table	310x500 mm	310x500 mm
Sliding panel size	1550x270 mm	1550x270 mm
Cross cut table size	680x580 mm	680x580 mm
Cross cut fence	1200-2200 mm	1200-2200 mm
Main blade size	254x30x3 mm	315x30x3 mm 254x30x3 mm
Main blade speed	4000 rpm	4000 rpm
Scoring blade size	90x20x3 mm	90x20x3 mm
Scoring blade speed	5800 rpm	5800 rpm
Max cut depth	75 mm @ 90° 60 mm @ 45°	100 mm @ 90° (315) 75 mm @ 90° (254) 80 mm @ 45° (315) 60 mm @ 45° (254)
Max distance-blade to rip fence	1220 mm	1220 mm
Sliding panel stroke	1400 mm	1400 mm
Max cross cut width	1350 mm	1350 mm
Packing size	866x700x1040 mm 1610x320x245 mm	910x740x1040 mm 1610x320x245 mm
Weight(N.W/G.W)	247/297 kg	255/310 kg
Noise level (Unload)	85 dB(A)	85 dB(A)

NOTE: The above specifications and the constructions were current at the time this manual was published, but because of our policy of continuous improvement, we reserve the right to change specifications and the constructions without notice and without incurring obligations.

SAFETY



Warning!

For Your Own Safety, Read Instruction Manual Before Operating this Equipment

The purpose of safety symbols is to attract your attention to possible hazardous conditions. This manual uses a series of symbols and signal words which are intended to convey the level of importance of the safety messages. The progression of symbols is described below. Remember that safety messages by themselves do not eliminate danger and are not a substitute for proper accident prevention measures.



Danger!

Indicates an imminently hazardous situation which, if not avoided, WILL result in death or serious injury.



Warning!

Indicates a potentially hazardous situation which, if not avoided, COULD result in death or serious injury.



Caution!

Indicates a potentially hazardous situation which, if not avoided, MAY result in minor or moderate injury. It may also be used to alert against unsafe practices.

Notice!

This symbol is used to alert the user to useful information about proper operation of the equipment.

Safety Instructions for Power Tools

- KEEP GUARDS IN PLACE** and in working order.
- REMOVE ADJUSTING KEYS AND WRENCHES.**
Form a habit of checking to see that keys and adjusting wrenches are removed from tool before turning on.
- KEEP WORK AREA CLEAN.** Cluttered areas and benches invite accidents.
- DO NOT USE IN DANGEROUS ENVIRONMENT. DO NOT** use power tools in damp or wet locations, or where any flammable or noxious fumes may exist. Keep work area well lighted.
- KEEP CHILDREN AND VISITORS AWAY.** All children and visitors should be kept at a safe distance from work area.
- MAKE WORKSHOP CHILD PROOF** with padlocks, master switches, or by removing starter keys.
- DO NOT FORCE TOOL.** It will do the job better and safer at the rate for which it was designed.
- USE RIGHT TOOL. DO NOT** force tool or attachment to do a job for which it was not designed.
- USE PROPER EXTENSION CORD.** Make sure your extension cord is in good condition. Conductor size should be in accordance with amperage rating. An undersized cord will cause a drop in line voltage resulting in loss of power and overheating. Your extension cord must also contain a ground wire. Always repair or replace extension cords if they become damaged.
- WEAR PROPER APPAREL. DO NOT** wear loose clothing, gloves, neckties, rings, bracelets, or other jewelry which may get caught in moving parts. Non-slip footwear is recommended. Wear protective hair covering to contain long hair.
- ALWAYS USE SAFETY GLASSES.** Also use face or dust mask if cutting operation is dusty. Everyday eyeglasses only have impact resistant lenses, they are NOT safety glasses.
- SECURE WORK.** Use clamps or a vise to hold work when practical. It is safer than using your hand and frees both hands to operate tool.
- DO NOT OVERREACH.** Keep proper footing and balance at all times.
- MAINTAIN TOOLS WITH CARE.** Keep tools sharp and clean for best and safest performance. Follow instructions for lubricating and changing accessories.
- USE RECOMMENDED ACCESSORIES.** Consult the instruction manual for recommended accessories. The use of improper accessories may cause risk of injury.
- REDUCE THE RISK OF UNINTENTIONAL STARTING.** On machines with magnetic contact starting switches there is a risk of starting if the machine is bumped or jarred. Always disconnect from power source before adjusting or servicing. Make sure switch is in OFF position before reconnecting.
- MANY WOODWORKING TOOLS CAN “KICKBACK” THE WORKPIECE** toward the operator if not handled properly. Know what conditions can create “kickback” and know how to avoid them. Read the manual accompanying the machine thoroughly.
- CHECK DAMAGED PARTS.** Before further use of the tool, a guard or other part that is damaged should be carefully checked to determine that it will operate properly and perform its intended function. Check for alignment of moving parts, binding of moving parts, breakage of parts, mounting, and any other conditions that may affect its operation. A guard or other part that is damaged should be properly repaired or replaced.
- NEVER LEAVE TOOL RUNNING UNATTENDED. TURN POWER OFF. DO NOT** leave tool until it comes to a complete stop.
- NEVER OPERATE A MACHINE WHEN TIRED, OR UNDER THE INFLUENCE OF DRUGS OR ALCOHOL.** Full mental alertness is required at all times when running a machine.
- NEVER ALLOW UNSUPERVISED OR UNTRAINED PERSONNEL TO OPERATE THE MACHINE.** Make sure any instructions you give in regards to the operation of the machine are approved, correct, safe, and clearly understood.

Additional Safety Instructions for Panel Saws

- 1. SAFETY ACCESSORIES.** Always use the blade guard and riving knife on all "through-sawing" operations. Through-sawing operations are those when the blade cuts completely through the work-piece.
- 2. KICKBACK.** Be familiar with kickback. Kickback happens when the work-piece is thrown towards the operator at a high rate of speed. Until you have a clear understanding of kickback and how it occurs, DO NOT operate this table saw!
- 3. WORKPIECE CONTROL.** Make sure the work-piece is placed in a stable position on the table and is either supported by the rip fence or the crosscut table during cutting operations.
- 4. PUSH STICK.** Always use a push stick when ripping narrow stock.
- 5. OPERATOR POSITION.** Never stand or have any part of your body directly in-line with the cutting path of the saw blade.
- 6. REACHING OVER SAW BLADE.** Never reach behind or over the blade with either hand while the saw is running. If kickback occurs while reaching over the blade, hands or arms could be pulled into the spinning saw blade.
- 7. USING THE RIP FENCE AND THE CROSSCUT FENCE TOGETHER DURING A CUTTING OPERATION.** When using the crosscut fence, the work-piece should never be contacting the rip fence while the saw blade is cutting.
- 8. STALLED BLADE.** Turn the saw off before attempting to "free" a stalled saw blade.
- 9. COMFORTABLE CUTTING OPERATIONS.** Avoid awkward operations and hand positions where a sudden slip could cause your hand to move into the spinning saw blade.
- 10. EXPERIENCING DIFFICULTIES.** If at any time you are experiencing difficulties performing the intended operation, stop using the machine! Contact your agent.
- 11. BLADE HEIGHT.** Always adjust the blade to the proper height above the work-piece.
- 12. DAMAGED SAW BLADES.** Never use blades that have been dropped or otherwise damaged.
- 13. RIVING KNIFE ALIGNMENT.** Only operate the saw if the riving knife is aligned with the main blade.

Warning!

Like all machines there is danger associated with this Sliding Panel Saw. Accidents are frequently caused by lack of familiarity or failure to pay attention. Use this machine with respect and caution to lessen the possibility of operator injury. If normal safety precautions are overlooked or ignored, serious personal injury may occur.

Caution!

No list of safety guidelines can be complete. Every shop environment is different. Always consider safety first, as it applies to your individual working conditions. Use this and other machinery with caution and respect. Failure to do so could result in serious personal injury, damage to equipment, or poor work results.

Warning!

Statistics prove that most common accidents among table saw users can be linked to kickback. Kickback is typically defined as the high-speed expulsion of stock from the table saw toward its operator. In addition to the danger of the operator or others in the area being struck by the flying stock, it is often the case that the operator's hands are pulled into the blade during the kickback.

Preventing Kickback

Never attempt freehand cuts. If the work-piece is not fed perfectly parallel with the blade, a kickback will likely occur. Always use the rip fence or crosscut fence to support the work-piece.

Make sure the riving knife is always aligned with the blade. A misaligned riving knife can cause the work-piece to bind or stop the flow of the cut, resulting in an increased chance of kickback. If you think that your riving knife is not aligned with the blade, check it immediately!

Ensure that your table slides parallel with the blade; otherwise, the chances of kickback are extreme. Take the time to check and adjust the sliding table.

Use the riving knife during every cut. The riving knife helps maintain the kerf in the work-piece after it is cut, therefore, reducing the chance of kickback.

Feed cuts through to completion. Anytime you stop feeding a work-piece that is in the middle of a cut, the chance of binding, resulting in kickback, is greatly increased.

Protecting Yourself from Kickback

Even if you know how to prevent kickback, it may still happen. Here are some tips to reduce the likelihood of injury if kickback DOES occur:

Stand to the side of the blade during every cut. If a kickback does occur, the thrown work-piece usually travels directly in front of the blade.

Always wear safety glasses or a face shield. In the event of a kickback, your eyes and face are the most vulnerable part of your body.

Never, for any reason, place your hand behind the blade. Should kickback occur, your hand will be pulled into the blade.

Use a push stick to keep your hands farther away from the moving blade. If a kickback occurs, the push stick will most likely take the damage that your hand would have received.

SITE CONSIDERATIONS

General Condition:

1. Electrical connection: Steady state voltage: 0.9-1.1 of nominal voltage.
Frequency: 0.99-1.01 of nominal frequency continuously; 0.98-1.02 short time

The mains connection must have maximum 16A fuse.

Electrical supply which has protection devices of under-voltage, over-voltage, over-current as well as a residual current device (RCD) which maximum residual current rated at 0.03A.

2. Altitude are not exceeding 1000m,
Maximum ambient air temperature is +40 °C,
minimum ambient air temperature is not less than +5 °C,
Storage and transportation temperature range is -25 °C~+55 °C.
The relative humidity does not exceed 50% at a maximum temperature of +40 °C, higher relative humidity may be permitted at lower temperature (e.g. 90% @ 20 °C).

Floor Load

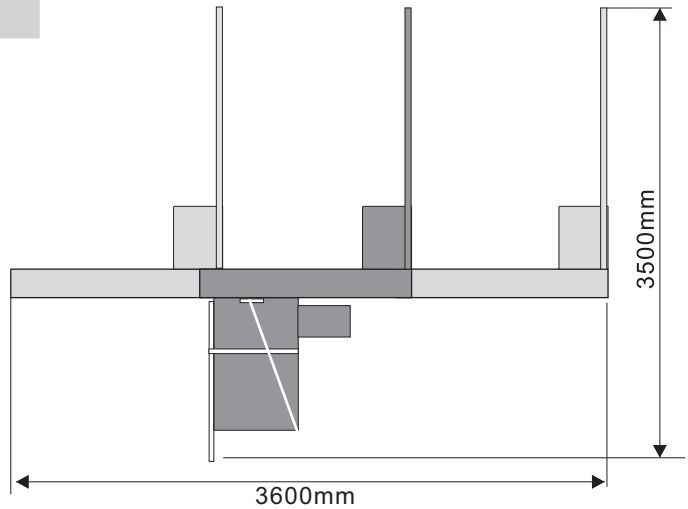
This machine represents a moderately large weight load in a small footprint. Most commercial shop floors will be adequate for the weight of the machine. Some floors may require additional support. Contact an architect or structural engineer if you have any question about the ability of your floor to handle the weight.

To ensure sufficient upright stability of the machine it should be bolted to floor. For this purpose 4 holes are provided in the machine's bracket of workstand.

Working Clearances

Working clearances can be thought of as the distances between machines and obstacles that allow safe operation of every machine without limitation. Consider existing and anticipated machine needs, size of material to be processed through each machine, and space for auxiliary stands and/or work tables. Also consider the relative position of each machine to one another for efficient material handling. Be sure to allow yourself sufficient room to safely run your machines in any foreseeable operation.

Consider existing and anticipated needs, size of material to be processed through each machine, and space for auxiliary stands, work tables or other machinery when establishing a location for your saw. See above figure for the maximum working clearances of the Sliding Panel Saw.



Lighting and Outlets

Lighting should be bright enough to eliminate shadow and prevent eye strain. Electrical circuits should be dedicated or large enough to handle combined motor amp loads. Outlets should be located near each machine so power or extension cords are not obstructing high-traffic areas. Be sure to observe local electrical codes for proper installation of new lighting, outlets, or circuits.

Dust Collector

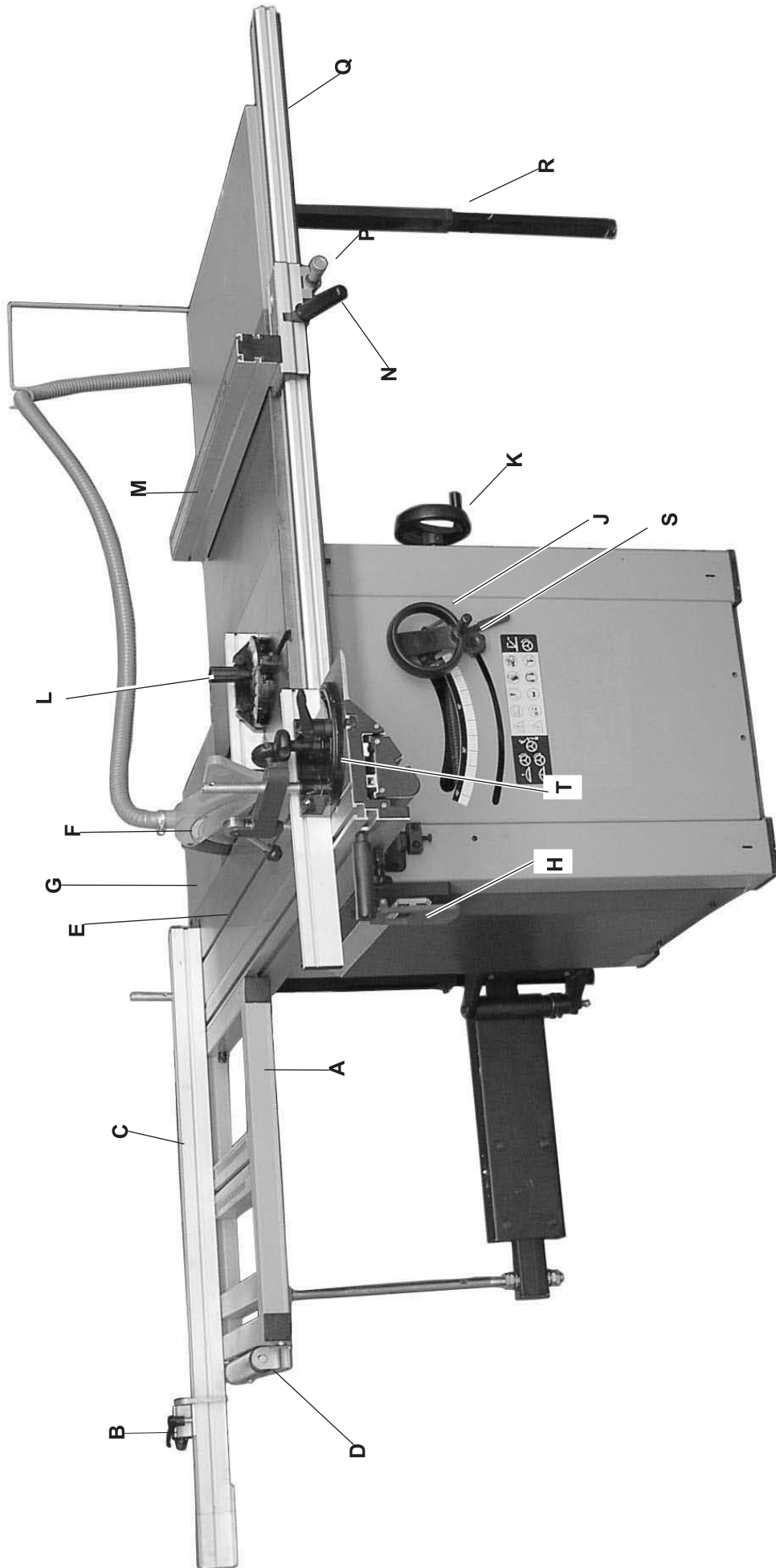
As a rule, this machine must be vacuumed during use. A time relayed socket is available as an accessory. In addition, the vacuum performance must be sufficient to achieve the required negative pressures and a maximum air speed of 20m/sec at the connector.



Warning!

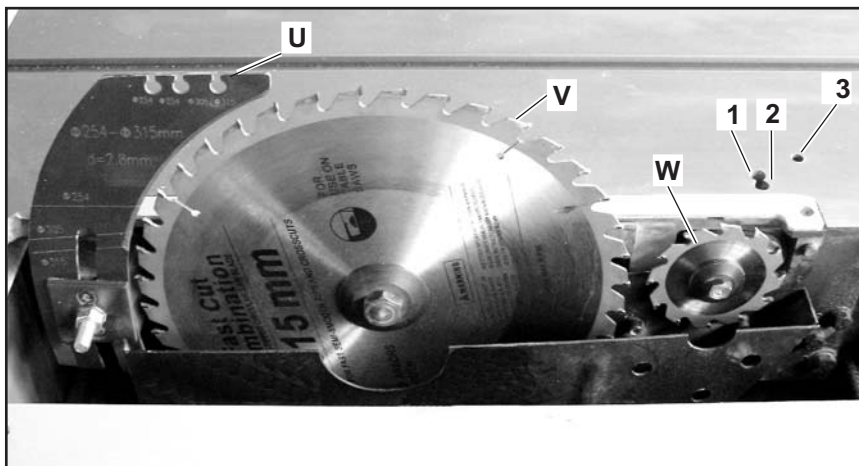
Read the manual before assembly and operation. Become familiar with the machine and it's operation before beginning any work. Serious personal injury may result if safety or operational information is not understood or followed.

GETTING TO KNOW YOUR SLIDING PANEL SAW



- A. Crosscut Table**—Provides a wide, stable platform for supporting full-size panels during crosscutting operations.
- B. Flip Stops**—Used for quick measurements for crosscutting.
- C. Crosscut Fence**—Used during crosscutting operations. Features a scale and multiple flip-style stopblocks for precise, repeatable crosscutting operations.
- D. Roller**—Used for supporting full-size panels during crosscutting operations.
- E. Sliding Panel**—Conveniently glides the work-piece through the blade with effortless precision and ease.
- F. Blade Guard**—Fully-adjustable blade guard allows high visibility of the cutting operation while maintaining maximum protection around the saw blade.
- G. Rear extension table**
- H. Power Switch**—Start/stops the machine and has emergency stop function.
- J. Blade Elevation Hand-wheel**—Adjust the height of the main saw blade.

- K. Blade Angle Hand-wheel**—Adjust the angle of the saw blades.
- L. Mitre Gauge**—This gauge aligns the wood for a cross-cut.
- M. Rip Fence**—Fully adjustable with fine adjustments. Fence face can be positioned for standard cutting operations, or in the lower position for blade guard clearance during narrow ripping operations.
- N. Fence Assembly Lock Down lever**—Secures the fence assembly into position along the fence rail.
- P. Fine-Adjust Knob**—Precisely adjusts the fence.
- Q. Rip Fence Rail**—Provides the support for rip fence.
- R. Support Leg**—Provides the support for the extension table.
- S. Main Blade Angle Lock Knob**—Secures the angle of main blade.
- T. Hold Down w/Mitre Gauge**—Holds the work-piece for sliding or mitre cutting.



- U. Riving Knife**—Maintains kerf during cutting operations. This function is crucial to preventing kickback caused by the kerf closing behind the blade.
- V. Main Blade**—Performs the cutting operations.
- W. Scoring Blade**—Small cutting blade that rotates opposite the main saw blade. The blade scores the workpiece before the actual cutting operation is performed; thus, preventing tear-out in laminate materials. The scoring blade is adjustable forward and backward, up and down, and in thickness of kerf.

- 1. Scoring Blade Alignment Screw**—Adjusts the lateral movement of the scoring blade.
- 2. Scoring Blade Lock Screw**—Locks the scoring blade after adjusted.
- 3. Scoring Blade Elevation Screw**—Adjusts the height of the scoring blade.

UNPACKING

The Sliding Panel Saw is shipped from the manufacturer in a carefully packed crate. If you discover the machine is damaged after you have signed for delivery, please call Customer Service immediately for advice. When you are completely satisfied with the condition of your shipment, you should inventory its parts.



The Sliding Panel Saw is a heavy machine. DO NOT over-exert yourself while unpacking or moving your machine you will need assistance and power equipment. Serious personal injury may occur if safe moving methods are not followed.

Caution!

Some metal parts may have sharp edges on them after they are formed. Please examine the edges of all metal parts before handling them. Failure to do so could result in injury.

Piece Inventory

After all the parts have been removed from the carton, you should have:

Main crate

- Main saw unit
- Cast iron extension table
- Steel plate extension table w/support leg
- Rear extension table w/support
- Swing arm assembly (inside main saw unit)
- Cross cut table
- Roller, cross cut
- Blade guard
- 2-1/2" dust hose
- Dust port
- Mitre gauge
- Hand wheels (2)
- Hardwares
- Tools
 - 13-15 mm open head wrench
 - Arbor wrench
 - Arbor pin
 - 3, 4, 5, 6 mm "L" wrench
- Push stick
 - (Some parts are inside the main saw unit)
- Edge shoe

Rail crate

- Rip fence
- Rip fence rail
- Rear support rail
- Sliding table
- Sliding table carrier
- Support leg, sliding carrier
- Cross cut fence
- Hold down w/fence
- Flip stop

Clean Up

The unpainted surfaces are coated with a light oil to protect them from corrosion during shipment. Remove this protective coating with a solvent cleaner or citrus-based degreaser. To clean thoroughly, some parts may need to be removed. For optimum performance from your machine, make sure you clean all moving parts or sliding contact surfaces that are coated. Avoid chlorine-based solvents as they may damage painted surfaces should they come in contact.

Warning!

Do not use gasoline or other petroleum-based solvents to clean with. They have low flash points which make them extremely flammable. A risk of explosion and burning exists if these products are used.

Caution!

Many of the solvents commonly used to clean machinery can be toxic when inhaled or ingested. Always work in well ventilated areas far from potential ignition sources when dealing with solvents. Use care when disposing of waste rags and towels to be sure they do not create fire or environmental hazards.

ASSEMBLY

Moving & Placing Saw Base Unit

Warning!

The Sliding Panel Saw is a heavy machine. Serious personal injury may occur if safe moving methods are not followed. To be safe, you will need assistance and power equipment when moving the shipping crate and removing the machine from the crate.

Warning!

Use lifting straps with a minimum of 500 kgs lifting capacity. If the lifting strap breaks, serious personal injury may occur.

1. Remove the top of crate and position the forklift forks together and directly above the saw.
2. Place four lift rings onto Saw Base Unit and place two lifting straps over the forks and attach the lifting rings.
3. Insert a wood block for protecting the main switch.
4. Lift the saw base unit and move it to your predetermined location.
5. Before lowering the saw into position, place four rubber blocks under the frame.
6. Lower the saw on the floor.



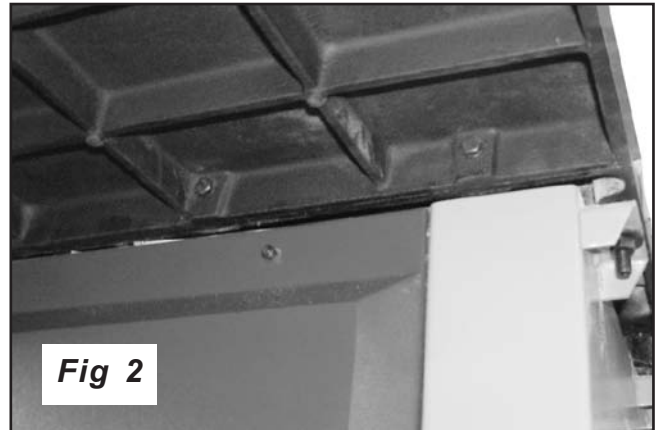
Install the extension table

Take out the cast iron extension table, steel plate extension table and rear extension table from the Saw Base Unit crate.

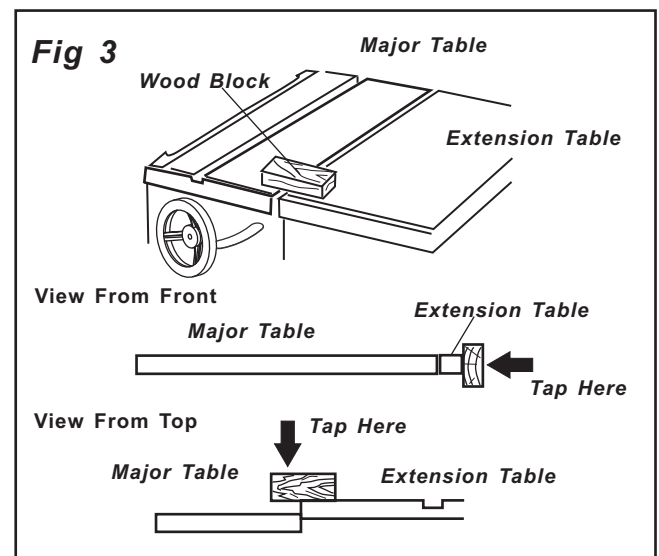
Warning!

The cast iron extension table is heavy part that weighs over 35 kgs. To be safer, you will need assistance.

1. Attach the Cast iron extension table to major table with 4-M8x20 hex head screws/ washers.



2. Center the extension table over the edges and tap it. Check the surface alignment.



3. Tighten 4-screws with 13 mm open head wrench.

Attach the steel plate extension table to cast iron extension table, Aligned and tighten them as "install the cast iron extension table".

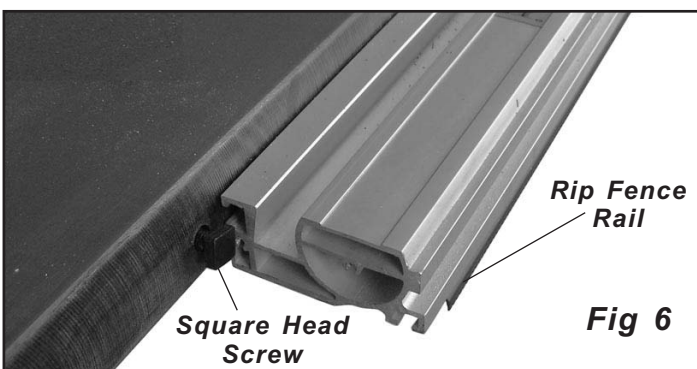
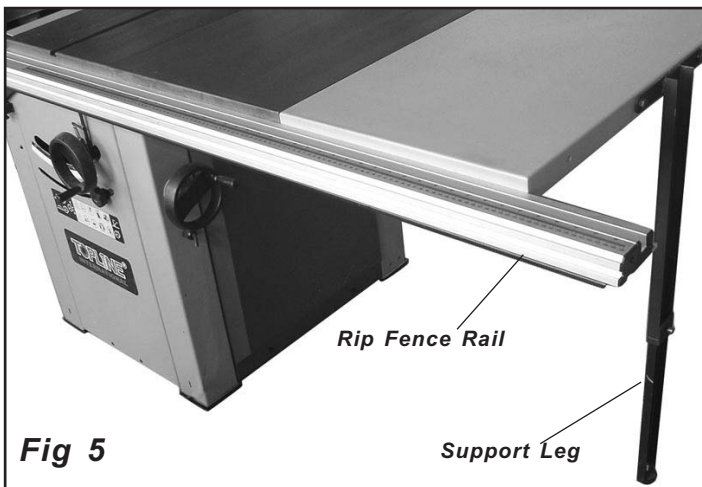


Install the support leg

1. Attach the support leg to steel plate extension table with 2-M8x20 Hex head screws, washers and nuts. And tighten them.
2. Adjust the support leg ensure the steel plate extension table at the same level with the cast iron extension table.

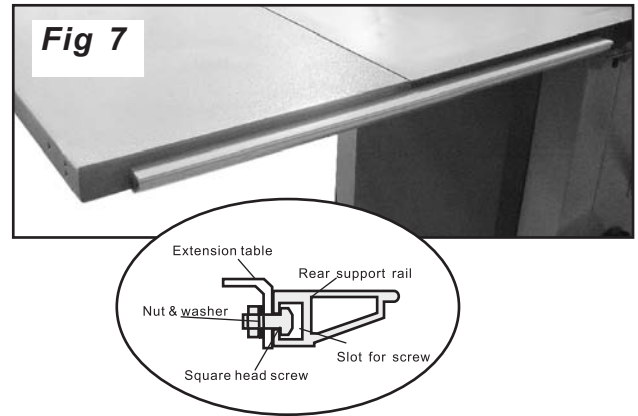
Install the rip fence rail

1. Place 5-M8x25 square head screws, washers and hex nuts onto major table and extension tables (washers and nuts inside table). The nuts only need to be turned a few turns so there is an adequate gap to fit the rip fence rail.
2. Remove the left end cap of rip fence rail. Slide the slot on the rip fence rail over 5-bolts. Adjust each bolt to fit the rail closely to table.
3. Push the rail against the tables and hand tight each hex nut. The rail needs further adjustment.
4. Put the left end cap onto rail, and tighten it with tapping screws.



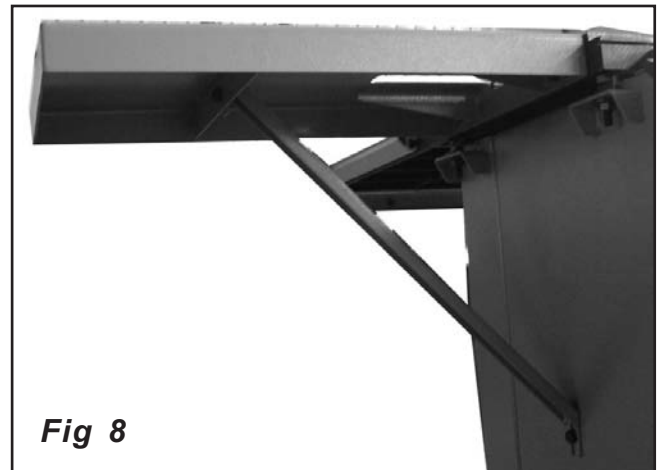
Install the rear support rail

Attach the rear support rail onto the cast iron and steel plate extension tables, with 4-M8x25 square head screws, washers and nuts, tighten them.



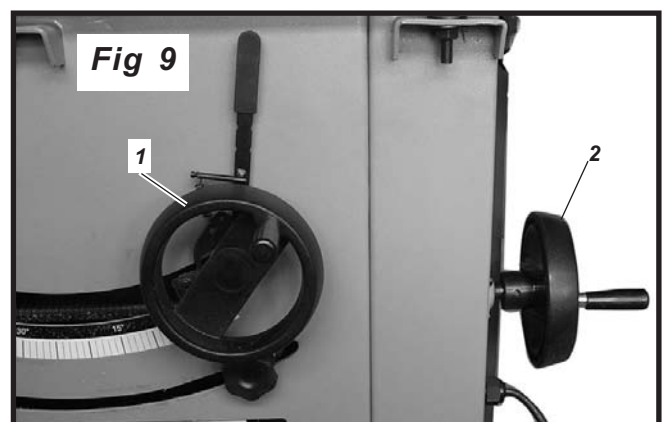
Install the rear extension table

1. Attach the rear extension table to the rear portion of major table with 2-M8x16 hex head screws washers, hex nuts.
2. Place the bracket onto rear panel of saw base unit with a M8x16 hex head screw, another end of bracket mounted to rear extension table with a M8x16 hex head screw.
3. Align the rear extension 0.5mm lower than the major table.



Install the main blade elevation & angle handwheel

1. Fitting the elevation handwheel(1) and angle handwheel (2) onto the elevation and angle shaft.



Fitting the rip fence and align the rail

1. Move the blade tilt to 0° (blade 90° to table), and raise the main blade as the way up.
2. Fit the profile of the rip fence carrier into the opposite profile on the rip fence rail.
3. Slide the rip fence touch the main blade.
4. Tap the right end of rip fence rail to ensure the '0' scale on rail aligned with the red line on lens of rip fence carrier.

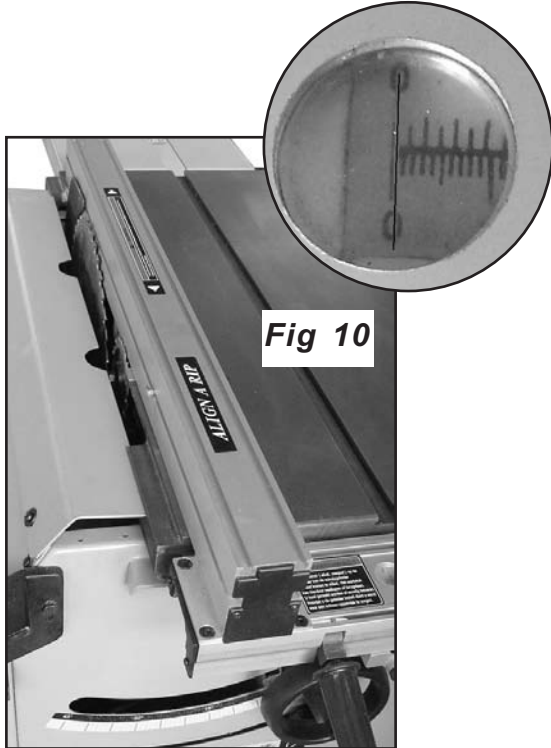


Fig 10

Install the swing arm assembly

1. Place 4 M8x30 hex head screws to mount the swing arm assembly to the saw base unit, and keep the arm on horizontal level.

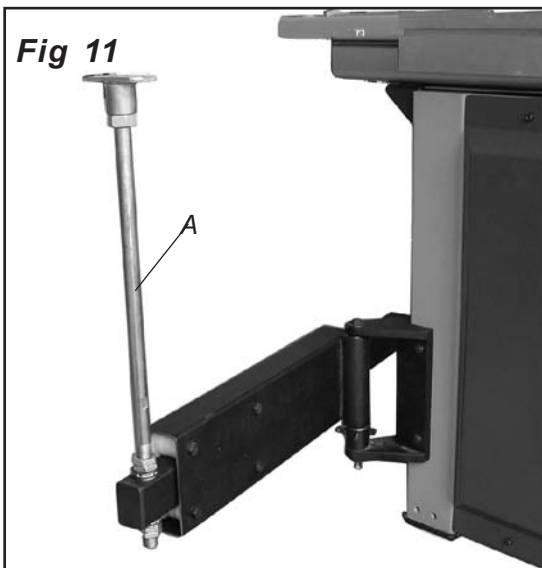


Fig 11

2. Place the cross-cut table support (A) onto the swing arm assembly, and hand tighten the lock nuts. The support needs further adjustment.

Install the Sliding panel assembly

1. Place 2 sets of star-type screws (include 8mm washer, insert, screw guide) into the lower slot of sliding panel carrier (see above 14).



Fig 12

2. Put the sliding panel assembly onto the sliding panel supports, and lay two star-type screws as fig 15 show.

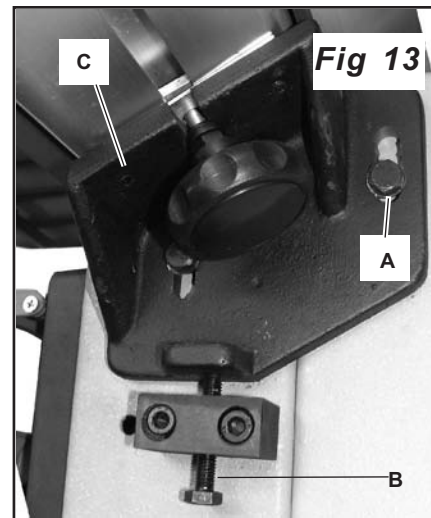


Fig 13

3. Tighten two star-type screws.

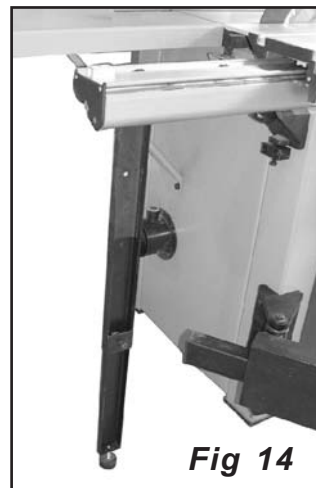


Fig 14

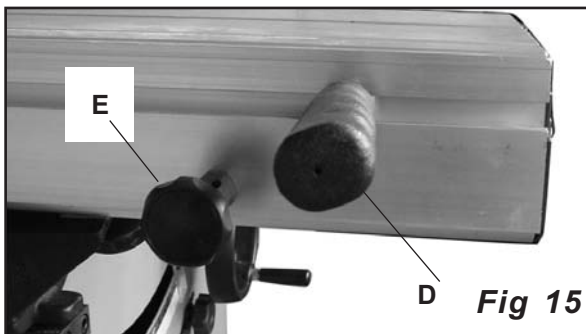
4. Install the support leg to the sliding carrier.

Adjust the sliding panel level:

1. Place a level rule (cross cut fence) on to major table and sliding panel.
2. Loosen 4-M8x25 hex screws(A) , adjust the M8x40 hex screw(B) to adjust the sliding panel level(fig 13).
3. Then re-tighten 4-M8x25 hex screws (A).
4. To fine adjust, using 3 mm "L" wrench to adjust 4-M8x12 set screws(C).

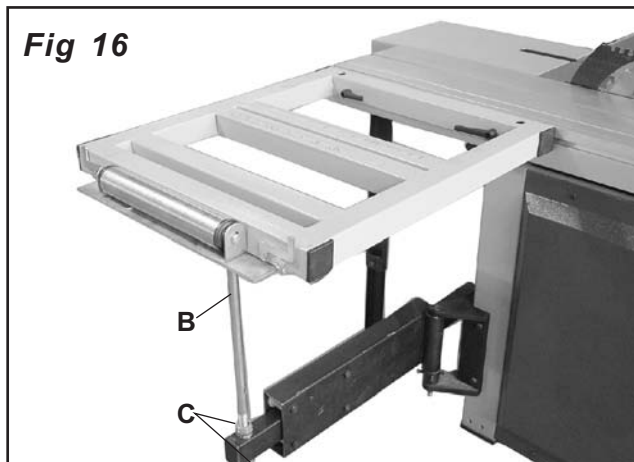
Install the push handle and lock pin

1. Sliding the M12x1.75 T-nut into the sliding panel and thread in push handle(D) with a 17 mm open end wrench.
2. Insert the star-type lock pin (E) into sliding panel, and lock the M10 hex nut on the opposite side.



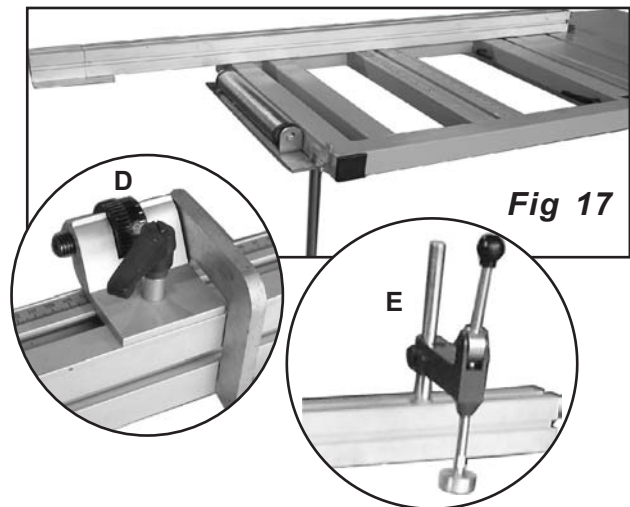
Install the cross cut table

1. Slide two M8x70 carriage bolts with T-blocks into the side slot of sliding panel. Attached the crosscut table to sliding panel.
2. Use 2 wing nuts mounted the cross cut table to sliding panel.
3. Use 2 M6x30 Hex head screws mounted the cross cut table to support(B).
4. Adjust 4-M12 thin hex nut (C) to adjust the cross cut table on the line with sliding panel.
5. Then tighten 4-M12 thin nut (C).



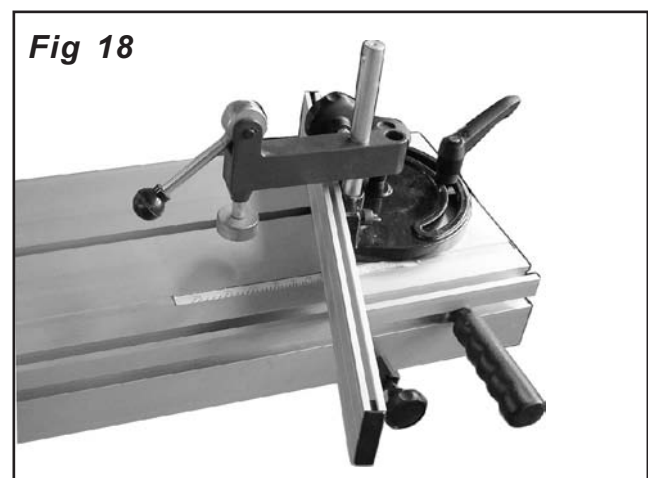
Install the cross cut fence

1. Drop the cross cut fence into the forward or rear guide pin hole.
2. Tighten the knurled nut.
3. Turn the "Z" lock plate to quick aligning the fence to table.
4. Turn the star type screw and clamped the fence in position.
5. Slide the flip stop(D) into the fence.
6. Place a T-nut into the top slot of fence, thread the stud of hold-down on fence.
7. If need, put the hold down arm onto the stud (E).



Install the hold down/Mitre Gauge

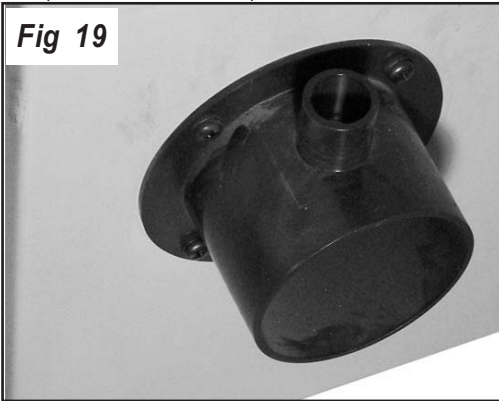
1. Slide the hold down/Mitre Gauge onto the sliding table and push it as far as possible. And lock the hold down/mitre gauge on table with the star-type lock handle (A) locked.
2. Aligned the Mitre Gauge fence on it.



Install the dust port

Place the dust port onto the bottom of rear panel, tighten it with 4 M6x12 pan head screws washers and nuts (nuts inside stand).

Fig 19



Install the blade guard

The riving knife cuts 3 slot for different blade size.

For PS10 the blade guard mounts to the 254 slot.

For PS12, if using the 254 mm blade place the blade guard onto 254 slot; if using the 305 or 315 mm place the blade onto 315 slot.

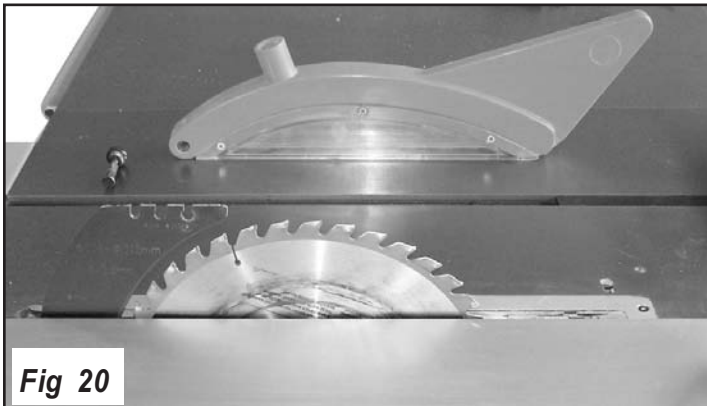


Fig 20

Install the dust hose support

To install the dust hose support onto the rear portion of steel plate extension table with 2 M6x20 hex head screws washers and nuts (nuts under the table).

Fig 21



Install dust hoses

1. Install the 2" dust hose onto the blade guard with 2" hose clamp.
2. Put the 2" dust hose onto dust hose support, keep free with the working table.
3. Another end of 2" dust hose clamps to the main dust port on the bottom of rear panel.
4. Install 4" dust hose to main dust port with 4" hose clamp

Fig 22

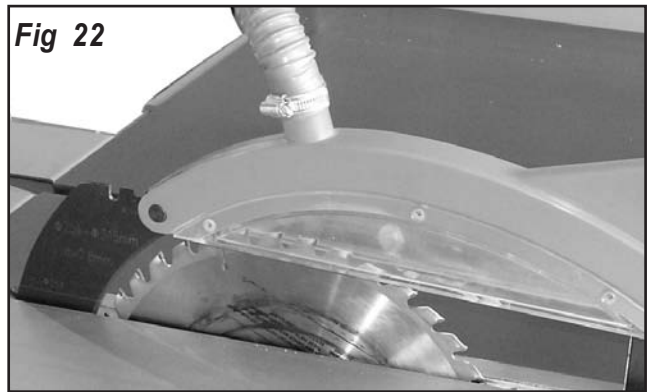


Fig 23

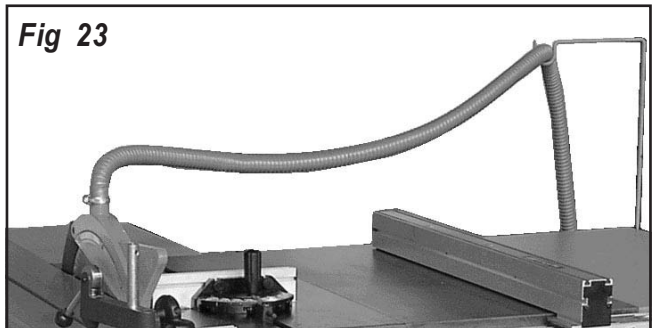


Fig 24



REPLACEMENT & ADJUSTMENT

Replace the main blade

Warning!

Disconnect the saw from the power source!

Caution!

The main blade dimension suitable for PS 12 machine is 254x30x3 (outer diameter, core diameter, thickness), 305x30x3, 315x30x3mm.

Caution!

The main blade dimension suitable for PS10 machine is 254x30x3 (outer diameter, core diameter, thickness) mm.

Attention!

But any time you change blade thickness, the appropriate sized riving knife and scoring blade must also be changed to match the size of main blade you install.

To change main blade:

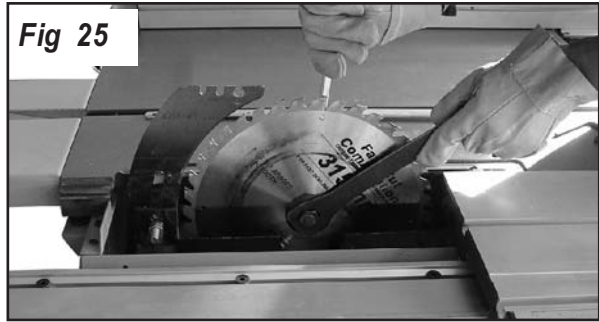
1. Move the blade tilt to 0° (Blade 90° to table) on the control panel and raise the blade as far as it will go.
2. Move the sliding panel all the way to the right and remove two M6x12 pan head screws to expose the internal blade guard that covers the blades and riving knife.
3. Remove the blade guard from the riving knife to expose the mounting assembly.
4. Remove the table insert.
5. Insert the arbor pin into the hole on blade inner flange and locks the blade.
6. Using the arbor wrench, remove the arbor nut that secures the main blade (turn clockwise to loosen).
7. Remove the arbor flange and the old main blade.
8. Install the new main blade, replace the arbor flange and nut, and tighten the arbor nut to secure the main blade.

Caution!

If you changed blade diameter sizes during this procedure, now is the time to adjust the riving knife. (Just for **PS12**)

If the kerf thickness is different from your old blade, the scoring blade kerf and riving knife thickness must match the new main blade kerf.

9. Make sure the correct size riving knife is installed and aligned with the blade.
10. Move the internal blade guard back into its original position, next to the blades, and center the sliding panel.
11. Align the scoring blade to the main blade .



Replace and adjusting the scoring blade

Warning!

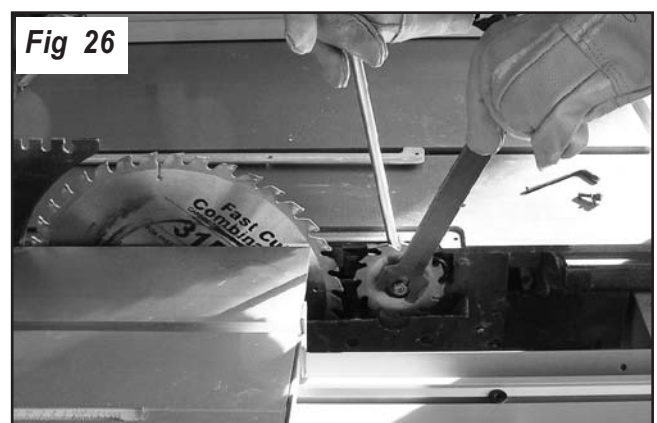
Disconnect the saw from the power source!

Caution!

Suitable for machine is 90x20x3 (outer diameter, core diameter, thickness) mm **Tapered Scoring Blade.**

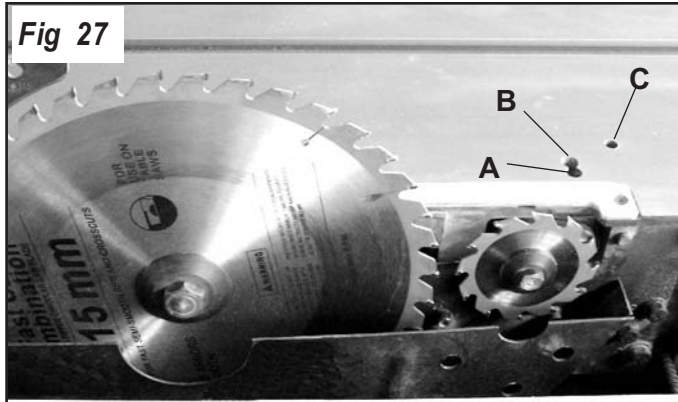
To replace scoring blade:

1. Move the blade tilt to 0° (Blade 90° to table) on the control panel and raise the blade as far as it will go.
2. Move the sliding panel all the way to the left and remove two M6x12 pan head screws to expose the internal blade guard that covers the blades and riving knife.
3. Remove the blade guard from the riving knife to expose the mounting assembly.
4. Remove the table insert.
5. Insert the arbor pin into the hole on blade inner flange and locks the blade.
6. Using the arbor wrench, remove the arbor nut that secures the main blade (turn anti-clockwise to loosen).
7. Remove the arbor flange and the old scoring blade.
8. Install the new scoring blade, replace the arbor flange and nut, and tighten the arbor nut to secure the scoring blade.



To align scoring blade:

Loosen the clamping screw (A). Lateral adjustment is made via adjusting screw (B). the height setting is made via setting screw (C). retighten the clamping screw (A). Adjust the scoring blade laterally so it is in line with the main saw-blade.



Replace and adjust the riving knives



Warning!

Disconnect the saw from the power source!

1. Move the blade tilt to 0° (Blade 90° to table) on the control panel and raise the blade as far as it will go.
2. Move the sliding panel all the way to the right and remove two M6x12 pan head screws to expose the internal blade guard that covers the blades and riving knife.
3. Remove the blade guard from the riving knife to expose the mounting assembly.
4. Remove the center bolt in the mounting assembly to remove the mounting plate.
5. Remove the currently installed riving knife and install the correct riving knife.
6. Replace the mounting plate and thread in the center bolt without completely tightening it.

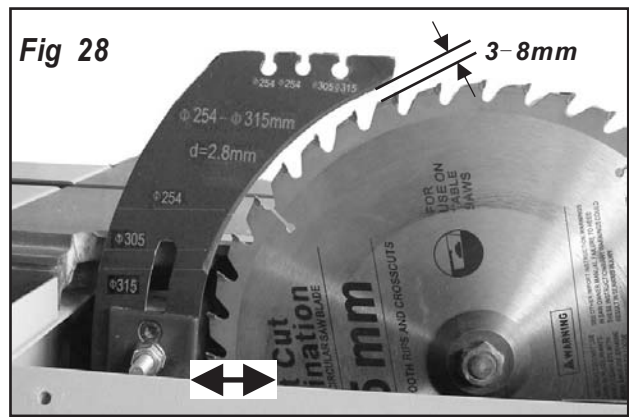


Caution!

The riving knife is carved with different blade size, just put the carved line under table.

The center carriage bolt is mounted in a horizontal slot, so the riving knife can move far or near the main blade.

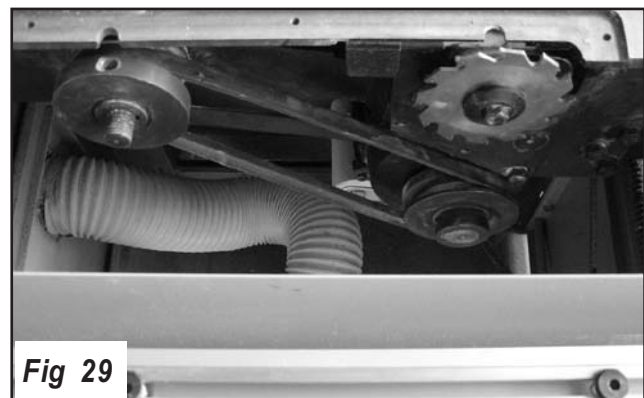
7. Position the riving knife about 3mm to 8mm away from the nearest carbide tooth on the main blade.
Note For a quick gauge, use the 3mm hex wrench to find the correct spacing between the blade and the riving knife.
8. Tighten the center bolt to secure the riving knife in position.
9. Move the internal blade guard (from step 4) back to its original position, and move the sliding panel back to center.

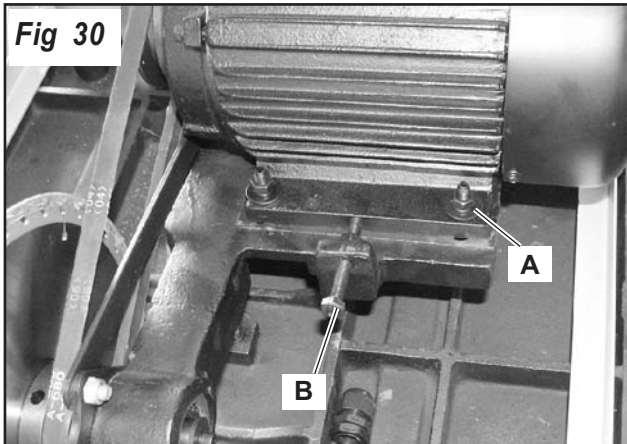


Replace the main belt

Disconnect the saw from the power source!

1. Move the blade tilt to 0° (Blade 90° to table) on the control panel and raise the blade as far as it will go.
2. Move the sliding panel all the way to the left and remove two M6x12 pan head screws to expose the internal blade guard that covers the blades and riving knife.
3. Remove the blade guard from the riving knife to expose the mounting assembly.
4. Remove the main blade.
5. Remove 3 M8x18 Allen screw and remove the chip house.
- Note** To remove lower 2-M8x18 Allen screws, the main blade angle system tilt to 30°, to remove the upper 1-M8x18 Allen screw, the main blade angle system tilt to 0°.
6. Remove the 4 Allen screws on the top and bottom of left panel, and remove the left panel.
7. Loosen motor amount 4-M8x40 hex head screws(A) and loosen the tension bolt(B).
8. Remove the V-belt.
9. Replace new V-belt, tighten motor bolts and the tension bolt, close the left panel, and re-mount blade inner guard, blade, blade guard.



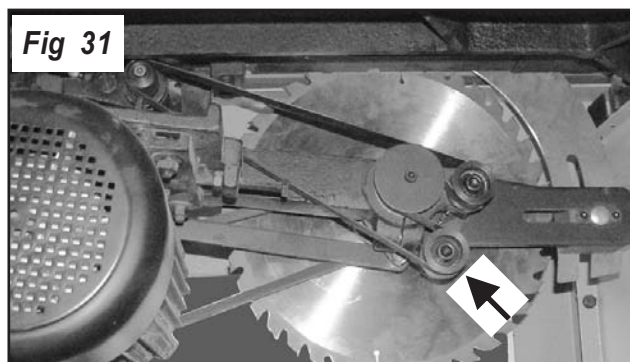


Replace the scoring belt

Warning!

Disconnect the saw from the power source!

1. Move the blade tilt to 0° (Blade 90° to table) on the control panel and lower the blade as far as it will go.
2. Remove the 4 Allen screws on the top and bottom of right panel, and remove the left panel.
3. Push the tension pulley as far as it will go as arrow show.
4. Remove the old belt and replace new belt.
5. Re-mount the right panel.



Sliding Panel Parallel Adjustment

Warning!

Disconnect the saw from the power source!

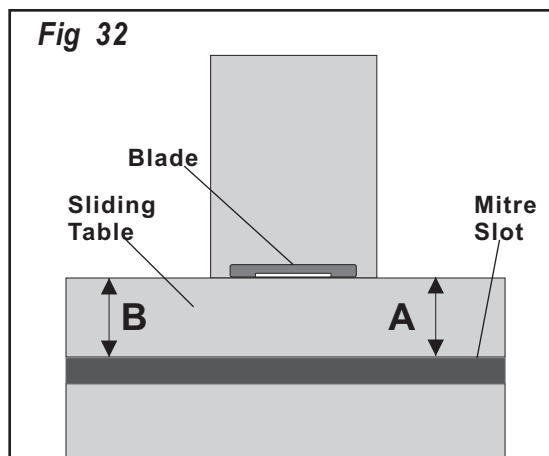
Now is the point in the assembly process to make the sliding panel parallel with the main saw blade and secure the sliding panel to the saw base.

Besides the tools included with the saw, this procedure requires you to have a precision ruler, a felt tip pen, and the assistance of another person.

To adjust the sliding panel parallel with the main blade:

1. Set the blade to 0° on the control panel (90° with the cast iron table).

2. Raise the main blade up as far as it will go.
3. Mark the center of the blade with a felt tip pen. This will allow you to take your measurements from the exact same place on the blade.
4. Move the sliding panel all the way to one end, and using a precision ruler, measure the gap between the edge of the panel and your mark on the blade as shown in Fig 32.

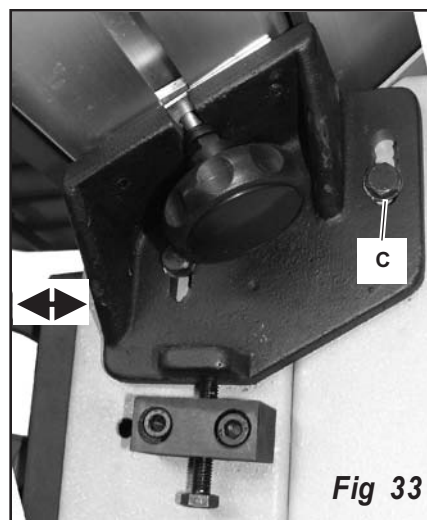


5. Move the other end of the sliding panel in front of the blade and measure the gap.

If the gap is the same on both sides, then the sliding panel is already parallel with the main blade.

If the gap on one side is different than the other, then continue with **step6**.

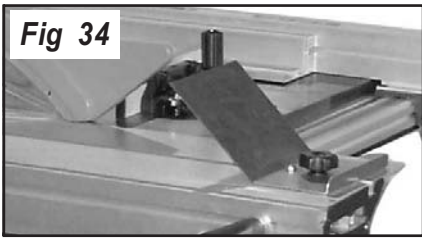
6. Move the end of the sliding panel that needs to be adjusted in front of the blade.
7. Loosen the two hex head screws (C) and light tap the sliding carrier support to adjust the gap.



8. Repeat **steps 7** until the gap between your mark on the blade and the edge of the sliding panel is even at both ends.
9. Tighten the four hex head screws (C) and secure supports in place
10. Now tighten the two star-type screws that secure the sliding panel to the base.

OPERATIONS

Fig 34

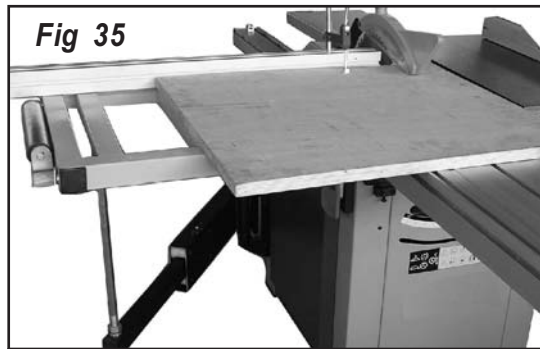


Your safety is important. To preventing work-piece kick-back, slide the edge shoe into sliding panel when needed. The edge shoe can slide into the front or rear portion of sliding panel.

Rip Cutting

The sliding panel saw has the capability of rip cutting full size panels. The sliding panel removes the burden of sliding a large and heavy panel over a stationary table surface.

Fig 35



This saw also has the capability of rip cutting smaller boards, using the machine as a traditional table saw. Smaller, lighter boards are easier to slide across the stationary cast iron table surface to the right of the saw blade.

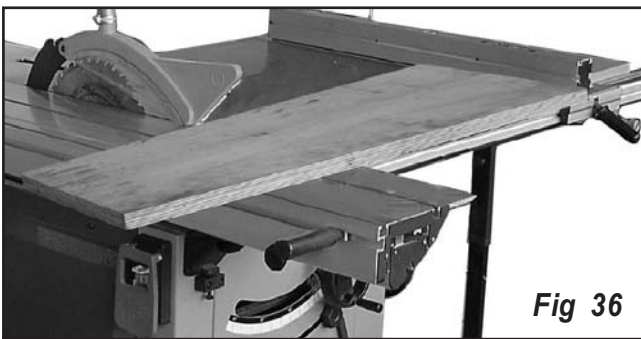


Fig 36

Determine which cutting operation will be best suited for the workpiece to be ripped.

To use the sliding table, read the instructions titled "Rip cutting with the sliding panel."

To use the machine as a traditional table saw, skip ahead to "Rip cutting using the traditional table saw technique."

Rip cutting with the sliding panel:

1. Mount the crosscut table to the sliding panel.
2. Slide and secure the crosscut table to the end of the sliding table opposite the sliding table handle.

3. Install the crosscut fence in the guide pin holes and lock it in place with the knurled nut.

Note *First, drop the crosscut fence into the forward guide pin hole, turn the "Z"lock plate to align the fence, then tighten the knurled nut.*

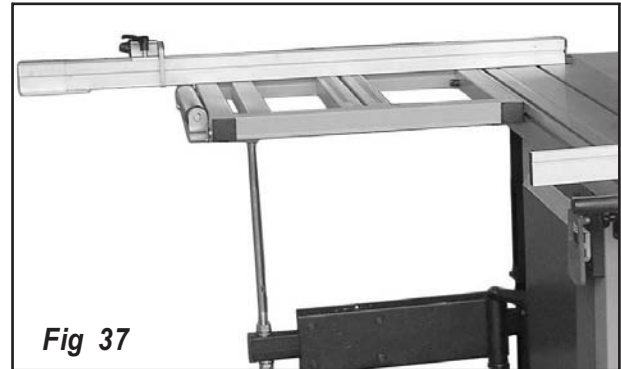


Fig 37

4. Set either flip stop to the desired width-of-cut.
5. Load the workpiece onto the table saw.
6. Mount the hold down arm onto the stud and lock the work-piece in place.
7. Once all the necessary safety precautions have been taken, perform the cutting operation.

Rip cutting using the traditional table saw technique:

1. Slide the crosscut table out of the way.
2. Lock the sliding panel into a stationary position.
3. Position the rip fence to the desired width-of-cut.
4. Once all the necessary safety precautions have been taken, load the workpiece onto the table saw and perform the cutting operation.

Crosscutting

With the crosscut fence mounted in the forward position, the sliding panel saw has the capability of crosscutting full size panels.

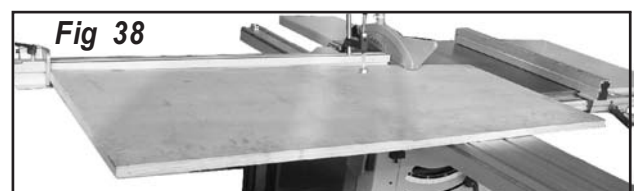


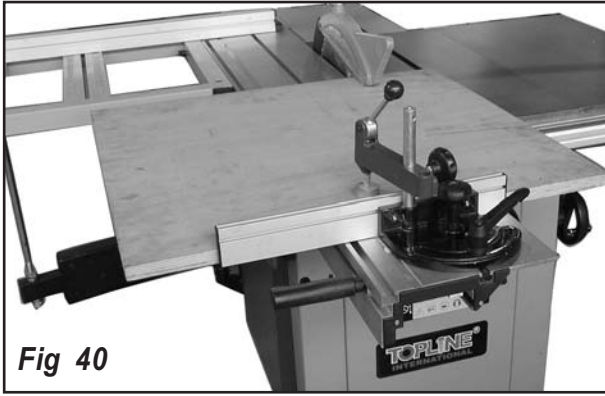
Fig 38

With the crosscut fence mounted in the rear position, this machine also has the capability of crosscutting smaller panels.

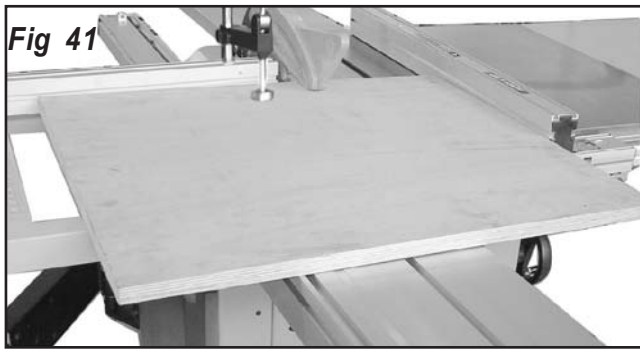


Fig 39

This machine has the capability of crosscutting workpieces while using the hold down w/mitre gauge.



Lastly, this machine has the capability of crosscutting workpieces while using the rip fence as a cut-off gauge.



Determine which cutting operation will be best suited for the workpiece to be crosscut.

If you will be crosscutting full size panels, then skip ahead to "Crosscutting full size panels."

If you will be crosscutting smaller panels, then skip ahead to "Crosscutting smaller panels."

If you will be crosscutting workpieces using the hold down, then skip ahead to "Crosscutting using the hold down w/mitre gauge."

If you will be crosscutting workpieces using the rip fence as a cut-off gauge, then skip ahead to "Crosscutting using the rip fence as a cut-off gauge."

Crosscutting full size panels:

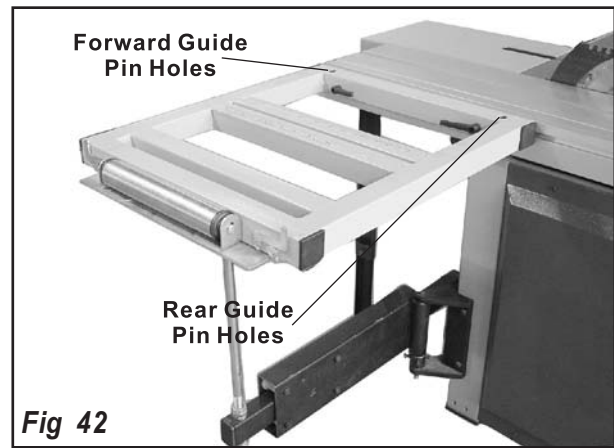
1. Mount the crosscut table to the sliding panel.
2. Install the crosscut fence in the forward guide pin holes and lock it in place.

Note *First, drop the crosscut fence into the forward guide pin hole, turn the "Z"lock plate to align the fence, then tighten the knurled nut.*

3. Set either flip stop to the desired width-of-cut.

Note *If the workpiece extends to the left of the saw blade more than 1200mm, then the crosscut fence slide needs to be extended.*

4. Load the workpiece onto the table saw.



5. Mount the hold down arm onto the stud and lock the work-piece in place.

6. Once all the necessary safety precautions have been taken, perform the cutting operation.

Crosscutting smaller panels:

1. Mount the crosscut table to the sliding panel.
2. Install the crosscut fence in the rear guide pin holes and lock it in place.

Note *First, drop the crosscut fence into the rear guide pin hole, turn the "Z"lock plate to align the fence, then tighten the knurled nut.*

3. Set either flip stop to the desired width-of-cut.

Note *If the workpiece extends to the left of the saw blade more than 1200mm, then the crosscut fence slide needs to be extended.*

4. Load the workpiece onto the table saw.
5. Mount the hold down arm onto the stud and lock the work-piece in place.
6. Once all the necessary safety precautions have been taken, perform the cutting operation.

Crosscutting using the hold down:

1. Mount the hold down onto the sliding panel.
2. Load the workpiece onto the table saw. Secure it using clamp.
3. Once all the necessary safety precautions have been taken, perform the cutting operation.

Crosscutting using the rip fence as a cut-off gauge:

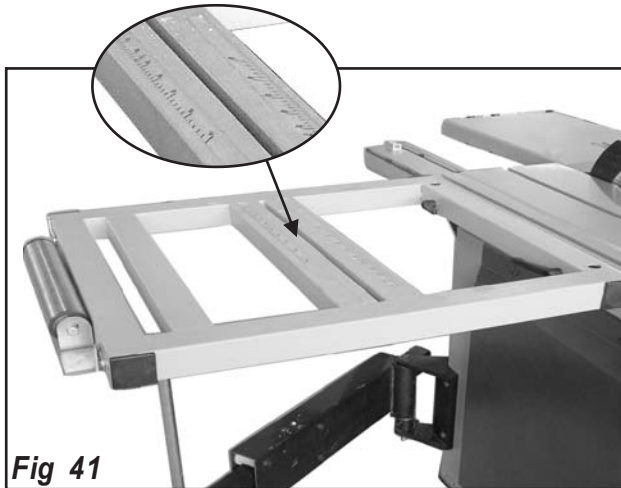
1. Mount the crosscut table to the sliding panel.
2. Install the crosscut fence in the rear guide pin holes and lock it in place.

Note *First, drop the crosscut fence into the rear guide pin hole, turn the "Z"lock plate to align the fence, then tighten the knurled nut.*

3. Position the rip fence to the desired width-of-cut.
4. Load the workpiece onto the table saw.
5. Mount the hold down arm onto the stud and lock the work-piece in place.
6. Once all the necessary safety precautions have been taken, perform the cutting operation.

Miter Cutting

The cross cut table built two scales for forward and rear mount fence to perform mitre cut.



Also the sliding panel built a scale for hold down to perform mitre cut.



Lastly, this machine has the capacity of mitre cutting work-piece using the mitre gauge.

To perform a miter cut using the cross cut fence:

1. Mount the cross cut fence onto the cross cut table.
2. Position the cross cut fence at the desired angle and use the ratchet lever to lock the cross cut fence in position.



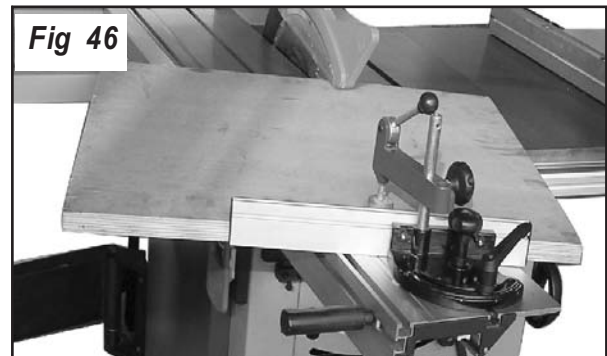
3. Position the flip stop according to the length of the workpiece you want to cut off to the left of the blade.

Note *If the workpiece extends to the left of the saw blade more than 1200mm, then the crosscut fence slide needs to be extended.*

4. Load the workpiece onto the table saw.
5. Mount the hold down arm onto the stud and lock the work-piece in place.
6. Once all the necessary safety precautions have been taken, perform the cutting operation.

To perform a miter cut using the hold down w/mitre gauge:

1. Mount the hold down onto sliding panel and fit a cut fence.
2. Position the hold down w/mitre gauge at the desired angle and use the ratchet lever to lock the mitre gauge in position.
3. Load the workpiece onto the sliding panel. Secure the workpiece with clamp.
4. Once all the necessary safety precautions have been taken, perform the cutting operation.



MAINTENANCE

Warning!

Always disconnect power to the machine before performing maintenance. Failure to do this may result in serious personal injury.

Cleaning

Cleaning the sliding panel saw is relatively easy. Vacuum excess wood chips and sawdust, and wipe off the remaining dust with a dry cloth. If any resin has built up, use a resin dissolving cleaner to remove it. Treat all cast iron and unpainted steel with a non-staining lubricant after cleaning.

Once a week:

- Clean sliding panel surface and grooves.
- Clean the cast iron or steel plate saw table.
- Clean the roller guide ways for the sliding table.
- Clean the aluminum rip fence and sliding grooves.
- Clean the rip fence bracket.

Once a month:

- Vacuum inside the motor cabinet.

Miscellaneous

Always be aware of the condition of your machine. Routinely check the condition of the following items and repair or replace as necessary:

- Loose mounting bolts.
- Worn switch.
- Worn or damaged blade.
- Worn or damaged blade guard.

V-Belts

To ensure optimum power transmission from the motor to the blade and to the hydraulic pump, the V-belts must be in good condition (free from cracks, fraying and wear) and operate under proper tension. Check the V-belts at least every 3 months; more often if the saw is used daily.

Replace the belts, if needed.

Bearings

The bearings are sealed and pre-lubricated and require no lubrication during their usable life. However, your saw components will operate at their best if the bearing surfaces are kept clean this is especially important for the trunnion bearings.

ELECTRICAL

Main switch

This machine is equipped with a knee touch no-volt release main switch and a limit switch.

The main switch is equipped a large size touch panel, during performance cutting work, any part of man body touched the switch panel, it can bring the saw stop.



Limit switch

The limit switch is mounted under the inner guard, if your make scoring blade or main blade replacement, remove the inner guards, the limit switch keep "off" position. Reduce the risk of unintentional starting.

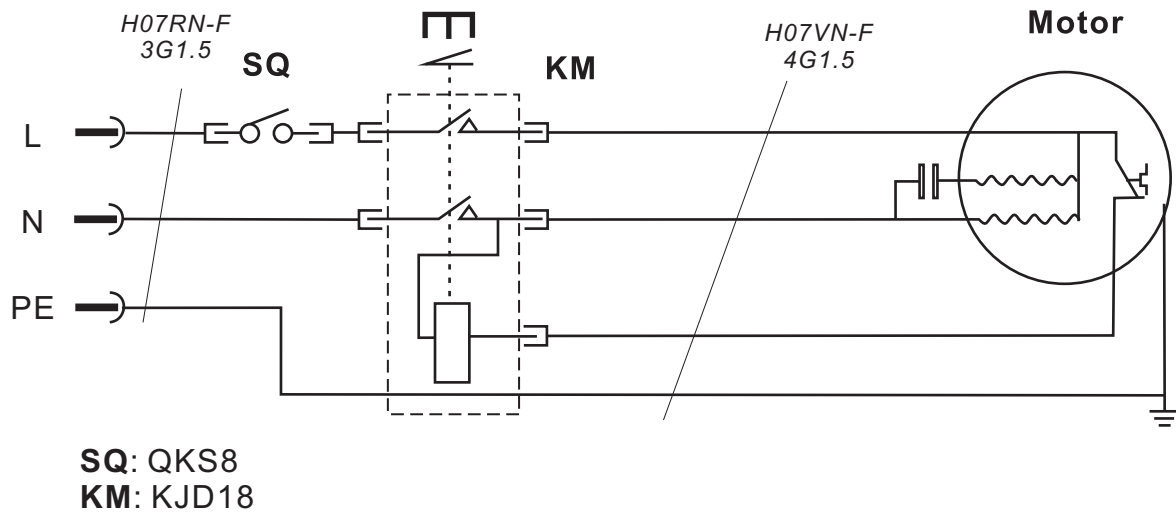


Thermo cut-out

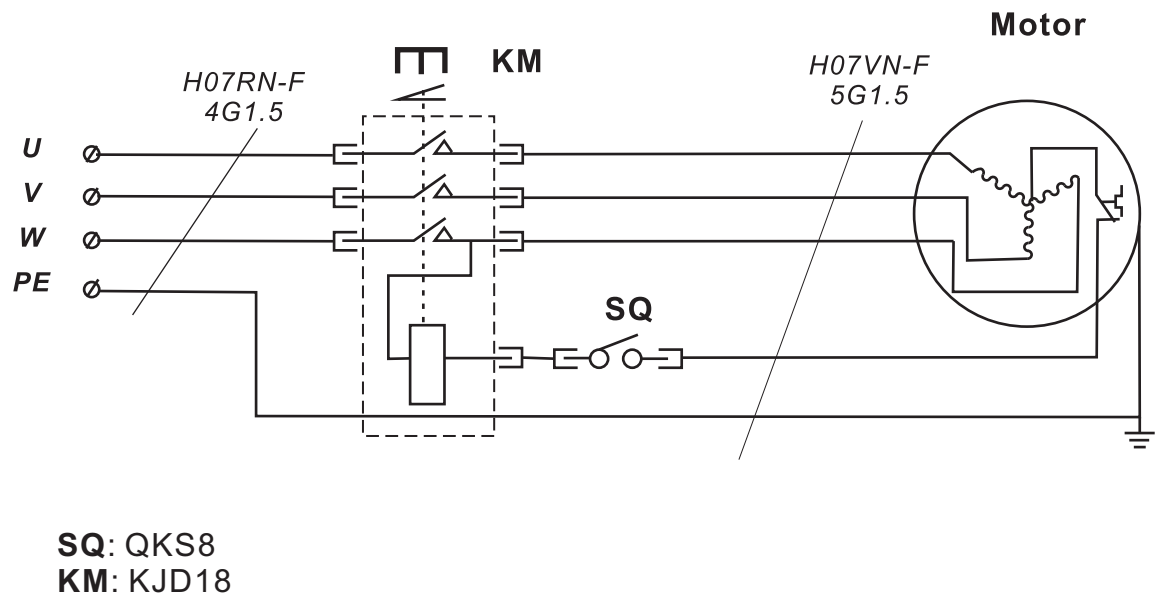
There is thermo cut-out inside the motor, this device protect the motor from being damaged in high temperature's condition. When the motor's temperature is too high the fuse will shut off automatically, you should check the reasons to cause the high temperature or be carried out by qualified specialists at once. The thermo cut-out will return to normal automatically once the temperature low down.

Wiring Diagram

1~, Motor



3~, Motor



TROUBLESHOOTING

Symptom	Possible Cause	Possible Solution
Motor will not start.	<ol style="list-style-type: none"> 1. Low voltage. 2. Open circuit in motor or loose connections. 	<ol style="list-style-type: none"> 1. Check power line for proper voltage. 2. Inspect all lead connections on motor for loose or open connections.
Motor will not start; fuses or circuit breakers blow.	<ol style="list-style-type: none"> 1. Short circuit in line cord or plug. 2. Short circuit in motor or loose connections. 3. Incorrect fuses or circuit breakers in power line. 	<ol style="list-style-type: none"> 1. Inspect cord or plug for damaged insulation and shorted wires. 2. Inspect all connections on motor for loose or shorted terminals or worn insulation. 3. Install correct fuses or circuit breakers.
Motor overheats.	<ol style="list-style-type: none"> 1. Motor overloaded. 2. Air circulation through the motor restricted. 	<ol style="list-style-type: none"> 1. Reduce load on motor. 2. Clean out motor to provide normal air circulation.
Motor stalls (resulting in blown fuses or tripped circuit).	<ol style="list-style-type: none"> 1. Short circuit in motor or loose connections. 2. Low voltage. 3. Incorrect fuses or circuit breakers in power line. 4. Motor overloaded. 	<ol style="list-style-type: none"> 1. Inspect connections on motor for loose or shorted terminals or worn insulation. 2. Correct the low voltage conditions. 3. Install correct fuses or circuit breakers. 4. Reduce load on motor.
Machine slows when operating.	<ol style="list-style-type: none"> 1. Applying too much pressure to workpiece. 2. Belts loose 	<ol style="list-style-type: none"> 1. Feed workpiece slower. 2. Tighten belts.
Loud, repetitious noise coming from machine.	<ol style="list-style-type: none"> 1. Pulley setscrews or keys are missing or loose. 2. Motor fan is hitting the cover. 3. V-belts are defective 	<ol style="list-style-type: none"> 1. Inspect keys and setscrews. Replace or tighten if necessary. 2. Tighten fan or shim cover. 3. Replace V-belts.
Blade is not square w/miter slot or fence is not square to blade	<ol style="list-style-type: none"> 1. Blade is warped. 2. Table top is not parallel to blade. 3. Fence is not parallel to blade 	<ol style="list-style-type: none"> 1. Replace blade. 2. Make table parallel to blade. 3. Make fence parallel to blade.
Fence hits table top when sliding on to the table.	<ol style="list-style-type: none"> 1. Front rail is bolted too low on table. 2. Rear rail is bolted too low on the table. 	<ol style="list-style-type: none"> 1. Raise front rail. 2. Raise rear rail.
Blade does not reach 90°.	<ol style="list-style-type: none"> 1. 90° stop bolt is out of adjustment. 	<ol style="list-style-type: none"> 1. Adjust 90° stop bolt.
Blade hits insert at 45°.	<ol style="list-style-type: none"> 1. Hole in insert is inadequate. 2. Table out of alignment. 3. Blade position is incorrect. 	<ol style="list-style-type: none"> 1. File or mill the hole in the insert. 2. Align table. 3. Adjust blade position.
Blade will not go beneath table surface.	<ol style="list-style-type: none"> 1. Table top too low. 	<ol style="list-style-type: none"> 1. Raise table top w/washers.
Hand wheels won't turn.	<ol style="list-style-type: none"> 1. Hand wheel key is inserted too far. 2. Roll pin or setscrew in worm gear is contacting geared trunnion. 	<ol style="list-style-type: none"> 1. Remove hand wheel and adjust key. 2. Inspect roll pins and setscrews in the worm gear. Tighten if necessary.
Workpiece has chip out on the bottom edge.	<ol style="list-style-type: none"> 1. Scoring blade height is incorrect. 2. Scoring blade is not aligned with the main blade. 3. Scoring blade kerf does not match the main blade. 	<ol style="list-style-type: none"> 1. Adjust the height of scoring blade. 2. Align the scoring blade. 3. Change the scoring blade.
Sliding table saw does not cut square.	<ol style="list-style-type: none"> 1. Sliding table is not parallel to blade. 2. Rip fence is not parallel to blade. 3. Cross cut fence is not perpendicular to the blade. 	<ol style="list-style-type: none"> 1. Adjust the sliding table. 2. Adjust the fence. 3. Adjust the cross cut fence perpendicular to the blade.



Warning!

Disconnect power to the machine when performing any troubleshooting. Failure to do this may result in serious personal injury.

PARTS LIST & DIAGRAMS

Parts List Diagram A

<u>No</u>	<u>Description</u>	<u>No</u>	<u>Description</u>
A-1	Hex screw M8x20	A-22	Cover, switch box
A-2	Washer 8mm	A-23	Plastic plate
A-3	Hex nut M8	A-24	Strain relief
A-4	Front panel, saw base	A-25	Switch box
A-5	Pan head screw M6x12	A-26	External washer 4mm
A-6	Washer 6mm	A-27	Ground plate
A-7	Dust port	A-28	Washer 4mm
A-8	Riveted nut	A-29	Pan head screw M4x12
A-9	Right panel, saw base	A-30	Hold screw, push stick
A-10	Hex nut M6	A-31	Push stick
A-11	Rear panel, saw base	A-32	Internal guard
A-12	Left panel, saw base	A-33	Mount plate
A-13	Rubber feet	A-34	Pan head screw M5x16
A-14	Pan head screw M5x20	A-35	Rubber seal
A-15	Washer 5mm	A-36	Angle bracket
A-16	Wire clamp	A-37	Pan head screw M4x10
A-17	Hex nut M5	A-38	Angle bracket
A-18	Knee touch plate	A-39	Pan head screw M4x50
A-19	Taping screw ST4.2x20	A-40	Limit switch
A-20	Saw base frame	A-41	Hex nut M4
A-21	Main switch	A-42	Allen screw M6x12

Parts List Diagram B

<u>No</u>	<u>Description</u>	<u>No</u>	<u>Description</u>
B-1	Star-type, lock handle	B-22	Carriage bolt M6x40
B-2	Flat washer 8mm	B-23	Stud, hold down
B-3	Hex screw M8x25	B-24	Star-type knob, hold down
B-4	Hex screw M8x40	B-25	Arm, hold down
B-5	T-base, adjust	B-26	Allen screw M5x16
B-6	Set screw M8x12	B-27	Scale, sliding table
B-7	Bracket, sliding carrier	B-28	Disc, hold down
B-8	Stop screw	B-29	Circle ring 8mm
B-9	Insert, sliding carrier	B-30	Pin, hold down
B-10	T-nut, sliding carrier	B-31	spring, hold down
B-11	Hex nut M8	B-32	Stud, hold down
B-12	Bracket, sliding carrier	B-33	Circle ring 12mm
B-13	Allen screw M8x32	B-34	Eccentric, hold down
B-14	Sunk head screw M8x25	B-35	Handle, hold down
B-15	Wing nut	B-36	Handle knob, hold down
B-16	Washer 6mm	B-37	End cap, fence
B-17	Mitre gauge, hold down	B-38	Fence, mitre gauge
B-18	Ratchet lever	B-39	Hex head screw M8x16
B-19	Flat washer 10mm	B-40	Upper support
B-20	Star-type lock handle	B-41	Allen screw M8x25
B-21	T-block	B-42	Disc, insert

Parts List Diagram B *cont. . .*

No	Description	No	Description
B-43	Lower support	B-71	Hex nut M10
B-44	Adjustable disc	B-72	Lock guide
B-51	Scew guide	B-73	T-nut, push handle
B-52	Taping screw ST4.2x12	B-74	Set screw M8x12
B-53	End cap, sliding panel	B-75	Insert, ball frame
B-54	Allen screw M5x8	B-76	Roll pin 2x8
B-55	Sliding panel set	B-77	Ball 1/2"
B-56	End cap, sliding panel	B-78	Ball frame
B-57	Stop plate	B-79	Ball frame
B-58	Stop plate	B-80	End cap, sliding rail
B-59	Sunk head screw M6x18	B-81	Sliding table rail
B-60	"Z" lock plate	B-82	End cap, sliding rail
B-61	Sunk head screw M6x20	B-83	Allen screw M6x10
B-62	Eccentric cam	B-84	Sunk head screw M8x20
B-63	Push handle	B-85	Lock nut M8
B-64	Bush, push handle	B-86	Lock nut M6
B-65	End cap, knob	B-87	Thread stud
B-66	Star-type knob, lock pin	B-88	Hex nut M8
B-67	Roll pin 3x18	B-89	T-block
B-68	Bush, lock pin	B-90	Edge shoe
B-69	Spring, lock pin	B-91	Startype screw M8x20
B-70	Lock pin	B-92	Washer 8mm

Parts List Diagram C

No	Description	No	Description
C-1	Arbor nut (left)	C-25	Stop screw
C-2	Outer flange	C-26	Allen screw M10x30
C-3	Saw blade	C-27	Lock nut M8
C-4	V-belt 680mm	C-28	Riving knife bracket
C-5	Pulley, blade	C-29	Connection rod
C-6	Flat key 5x5x20	C-30	Sunk head screw M8x20
C-7	Arbor shaft	C-31	Bush, connection rod
C-8	Bearing 6201-2RS	C-32	Sunk head screw M8x30
C-9	Arbor shaft sleeve	C-33	Hex screw M6x65
C-10	Arbor shaft bush	C-34	Knurled nut for motor base
C-11	Circle ring 40mm	C-35	Motor base
C-12	Mount block, riving knife	C-36	Taping screw ST4.2x26
C-13	Collar stop	C-37	Set screw M6x10
C-14	Set screw M8x12	C-38	Handwheel, main blade
C-15	Spacer, elevation gear	C-39	Handle
C-16	Hex screw M8x20	C-40	Pan head screw M6x16
C-17	Washer 8mm	C-42	Washer 6 Jmm
C-18	Block plate	C-43	Housing, knob
C-19	Riving knife	C-44	Angle connection knob
C-20	Knurled nut	C-45	Roll pin 4x28
C-21	Carriage bolt M10x60	C-46	Angle adjust thread
C-22	Set screw M8x20	C-47	Elevation nail A
C-23	Set screw M8x20	C-48	Elevation connection rod
C-24	Hex nut M8	C-49	Elevation nail B

Parts List Diagram C *cont. . .*

No	Description	No	Description
C-50	Spacer, elevation gear	C-79	Angle bracket
C-51	Hex nut M6	C-80	Angle pointer
C-52	Adjusting frame	C-81	Washer 4mm
C-53	Circle ring 24mm	C-82	Spring washer 4mm
C-54	Knuckle	C-83	Pan head screw M4x10
C-55	Thin hex nut M12	C-84	Bracket, worm gear
C-56	Elevation gear	C-85	Chip house
C-57	Lock block	C-86	Allen screw M8x18
C-58	Motor	C-87	Hose clamp 100mm
C-59	Hex screw M8x40	C-88	Hex screw M6x25
C-60	Flat key 8x7x50	C-89	Dust hose Dia.100 x 800mm
C-61	Set screw M6x8	C-92	Arbor pin
C-62	Set screw M6x6	C-94	Roll pin 4x20
C-63	Pulley, motor	C-95	Spacer, lock lever
C-64	Hex screw M8x25	C-96	Allen screw M6x25
C-65	Lock washer 8mm	C-97	Swing plate, lock lever
C-66	Angle lock block	C-98	Bush, lock lever
C-67	Angle cradle	C-99	Lock lever, elevation
C-69	Hex nut M12	C-100	Handle, lock lever
C-70	Lock washer 12mm	C-101	Spring, lock lever
C-71	Worm gear	C-102	Taping screw ST4.2x10
C-72	Lock bolt, guard	C-103	Blade guard, half
C-73	Hex screw M8x20	C-104	Blade guard, half
C-74	Thread, worm gear	C-105	Segment, blade guard
C-76	Flat washer 8mm	C-106	Segment, blade guard
C-77	Star-type screw M8x20	C-107	Lock washer 8mm
C-78	Pan head screw M5x12		

Parts List Diagram D

No	Description	No	Description
D-1	Taping screw ST4.2x12	D-20	T-nut M5
D-2	Rear plate, fence	D-21	Washer 5mm
D-3	Bottom plate, fence	D-22	Pan head screw M5x10
D-4	Sunk head screw M5x8	D-23	Set screw M6x6
D-5	Fence	D-24	Fine adjusting handle
D-6	Wing nut	D-25	Coil spring, fine adjust
D-7	Screw guide	D-26	Eccentric arbor
D-8	Sunk head screw M6x12	D-27	Frame, fine adjust gear
D-9	Carriage screw M6x70	D-28	Gear rod, fine adjust
D-10	Fence plate	D-29	Core gear
D-11	Pan head screw M4x10	D-30	Washer 4mm
D-12	Circle ring	D-31	Rubber sticker
D-13	Len	D-32	End cap, fence carrier
D-14	Allen screw M6x16	D-33	Lock shaft, fine adjust
D-15	End cap, fence carrier	D-34	Screw guide
D-16	Fence carrier	D-35	Fence "L" shape
D-17	Lock handle, fence	D-36	Lock plate
D-18	Hex nut M8	D-37	End cap, lock handle
D-19	Eccentric shaft	D-38	Front plate, fence

Parts List Diagram E

No	Description	No	Description
E-1	Scale, cross cut table	E-41	Support, swing arm
E-2	Washer 6mm	E-42	Hex screw M8x30
E-3	Scale, cross cut table	E-43	Hex screw M10x25
E-4	Allen screw M6x12	E-44	Sunk head screw M6x12
E-5	Eccentric cam	E-45	T-nut, extension fence
E-6	Washer 8mm	E-46	Lock plate
E-7	Sunk head screw M6x10	E-47	T-block
E-8	"Z" lock plate	E-48	Scale
E-9	"Z" lock plate	E-49	End, extension fence
E-10	Hex screw M8x20	E-50	Carriage bolt M6x38
E-11	Lock nut M6	E-51	Screw guide
E-12	Hex nut M6	E-52	Flip stop base
E-13	End cap, cross cut table	E-53	Knurled knob
E-14	Cross cut table	E-54	Spring, flip stop
E-15	Roller	E-55	Set screw
E-16	Hex screw M8x12	E-56	Spacer , ratchet lever
E-17	Bracket, roller	E-57	Ratchet lever, Flip stop
E-18	Bracket, roller	E-58	Allen screw M8x20
E-19	Base, roller	E-59	Stud, flip stop
E-20	Support rod, cross cut table	E-60	Flip stop
E-21	Joint, support	E-61	Scale, extension fence
E-22	Thin hex nut M10	E-62	Extension fence
E-23	Bearing 8104	E-63	Scale, cross cut fence
E-24	Swing arm, extension	E-64	Taping screw ST4.2 x12
E-25	Pan head screw M5x12	E-65	End cap, cross cut fence
E-26	Insert, swing arm	E-66	Lock stud, cross cut fence
E-27	Woolen sheet	E-67	Carriage bolt M8x70
E-28	Block	E-68	T-block
E-29	Roll	E-69	Flat washer M8
E-30	Bearing 6101	E-70	Spacer, lock handle
E-31	Spacer, roll	E-71	Star-type lock handle
E-32	Pan head screw M5x6	E-72	Wing nut M8
E-33	Eccentric shaft	E-73	Stud, cross cut table
E-34	Swing arm	E-74	T-block
E-35	Hex screw M6x35	E-75	Knurled knob, fence
E-36	Stop collar	E-76	End cap, swing arm
E-37	Bearing 6202	E-77	T-block, hold down
E-38	Shaft, swing arm	E-78	Washer 12 mm
E-39	Hex screw M8x50	E-79	Stud, hold down
E-40	Thin nut M16		

Parts List Diagram F

No	Description	No	Description
F-1	Hex nut M8	F-7	Hex screw M6x12
F-2	Outer flange, scoring blade	F-8	Washer 6mm
F-3	Scoring blade	F-9	Pulley, scoring blade
F-4	Arbor, scoring blade	F-10	Circle ring 40mm
F-5	Bearing 6100-RS	F-11	Set screw M6x6
F-6	Flat belt	F-12	Adjusting shaft

Parts List Diagram F *cont. . .*

No	Description	No	Description
F-13	Housing, arbor	F-26	Lock nut M10
F-14	Spacer, scoring blade	F-27	Washer 10mm
F-15	Set screw M8x18	F-28	Tension spring
F-16	Eccentric shaft	F-29	Spacer, tension spring
F-17	Spring	F-30	Tension pulley bracket
F-18	Base, arbor	F-31	Tension pulley
F-19	Allen screw M6x12	F-33	Spacer, tension pulley
F-20	Stop screw	F-34	Allen screw M10x60
F-21	Hex nut M6	F-35	Pulley drive
F-23	Elevation, scoring blade	F-36	End cap, pulley drive
F-24	Hex nut M10	F-37	Hex screw m6x8
F-25	Allen screw M6x18	F-38	Coil spring

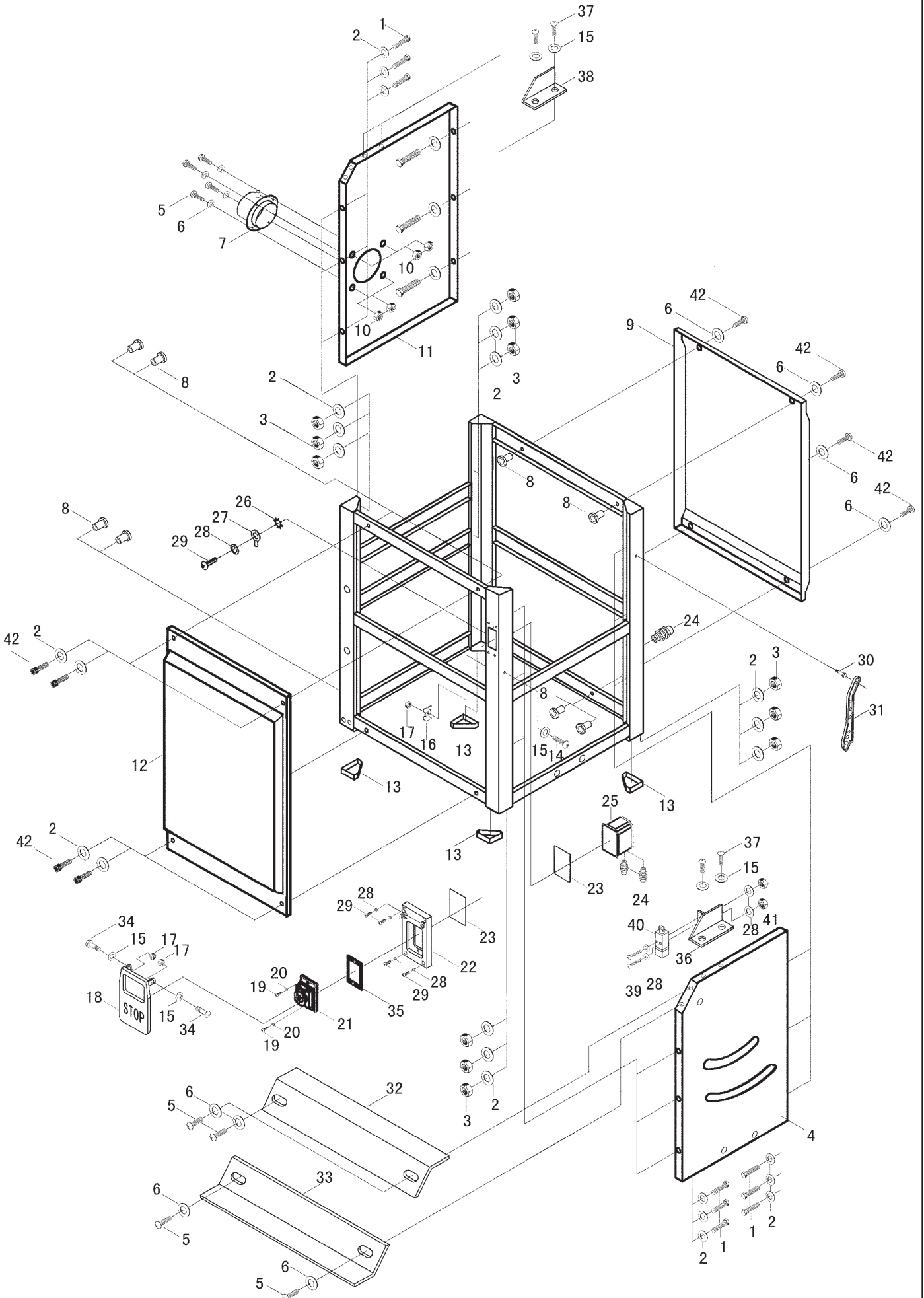
Parts List Diagram G

No	Description	No	Description
G-1	Rear extension table	G-20	Dust hose support
G-2	Washer 8mm	G-21	Washer 6mm
G-3	Hex nut M8	G-22	Hex screw M6x20
G-4	Set screw M6x12	G-23	Hex nut M6
G-5	Hex screw M8x16	G-26	Adjustable disc
G-6	Flat washer 10mm	G-27	Lower, support
G-7	Rea table support	G-28	Disc insert
G-8	Set screw M10x70	G-29	Allen screw M8x25
G-9	Hex nut M10	G-30	Upper, support
G-10	Major table	G-31	Taping screw ST4.2x12
G-11	Table insert	G-32	Washer 4mm
G-12	Sunk head screw M5x10	G-33	Right end cap, front rail
G-13	Hex screw M8x20	G-34	T-Nut M5
G-14	Front rail	G-35	Rack, fence
G-15	Square head screw M8x25	G-37	Lock washer 5mm
G-16	Extension table	G-38	Pan head screw M5x8
G-17	Steel extension table	G-39	Left end cap, front rail
G-18	Hose clamp 30mm	G-40	Scale, rail
G-19	Dust hose 30mm dia.x3240mm	G-41	Rear rail

Parts List Diagram H

No	Description	No	Description
H-1	Mitre gauge knob	H-11	Mitre gauge rod
H-2	Washer 6mm	H-12	Pan head screw M4x18
H-3	Mitre gauge base	H-13	Hex nut M4
H-4	Pan head screw M5x10	H-14	Scale , gauge
H-5	Indicator gauge	H-16	End cap, Gauge fence
H-6	Block indicator	H-17	Gauge fence
H-7	Stop pin	H-19	Carriage bolt M6x32
H-8	Sunk head screw M5x8	H-20	Washer 6mm
H-9	Roller, guage	H-21	Knurled nut
H-10	Guide pin		

DIAGRAM A



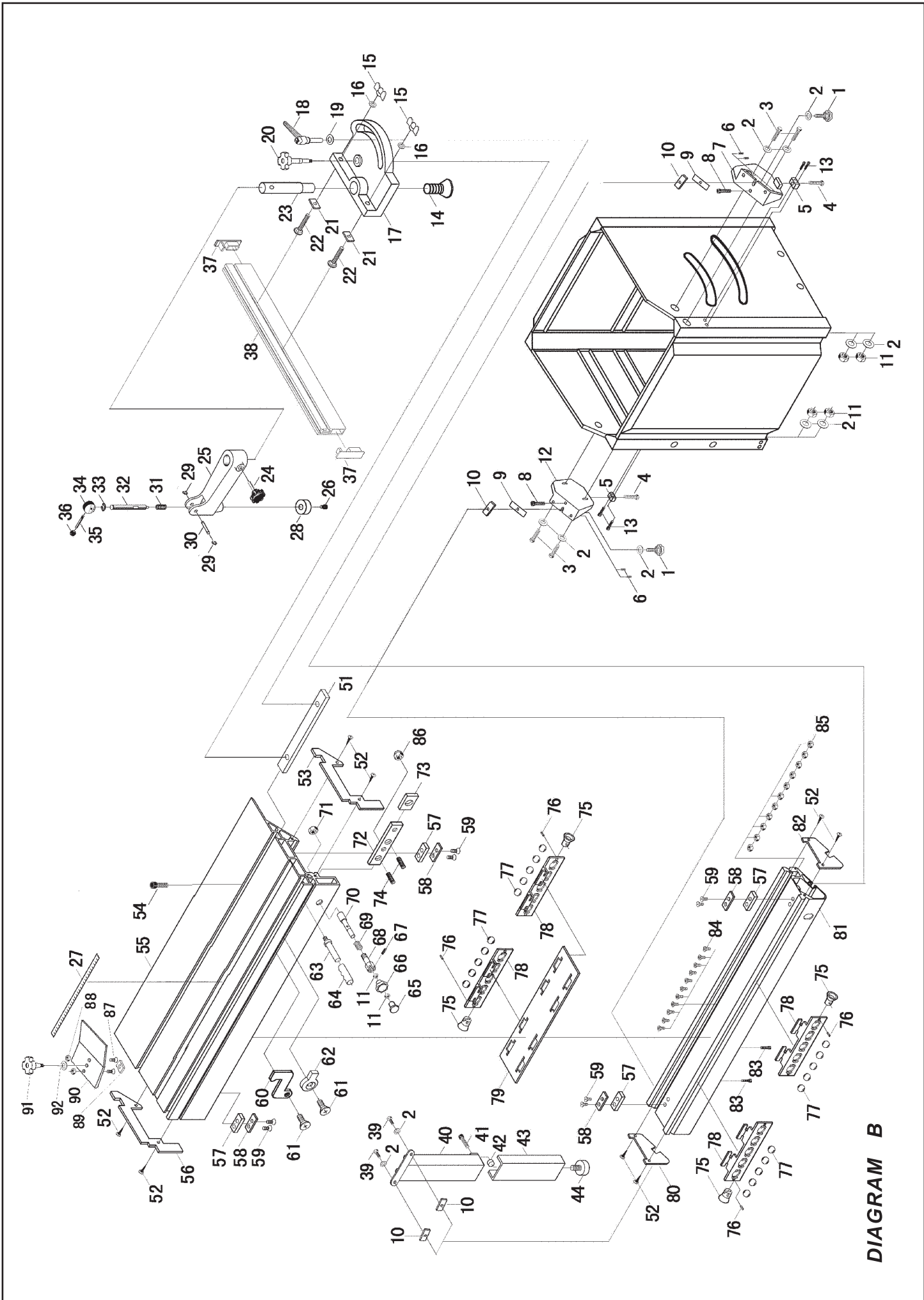


DIAGRAM B

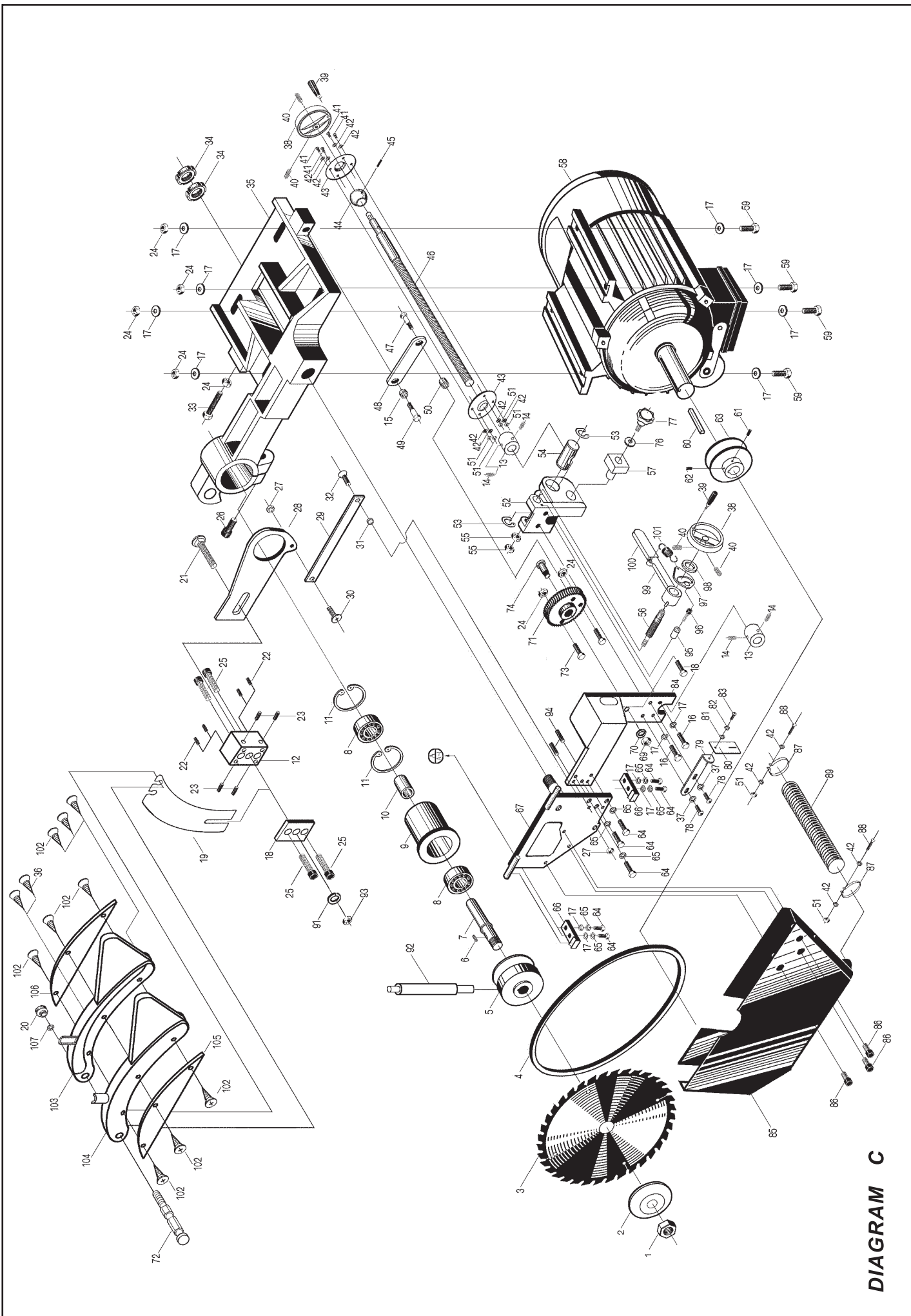


DIAGRAM C

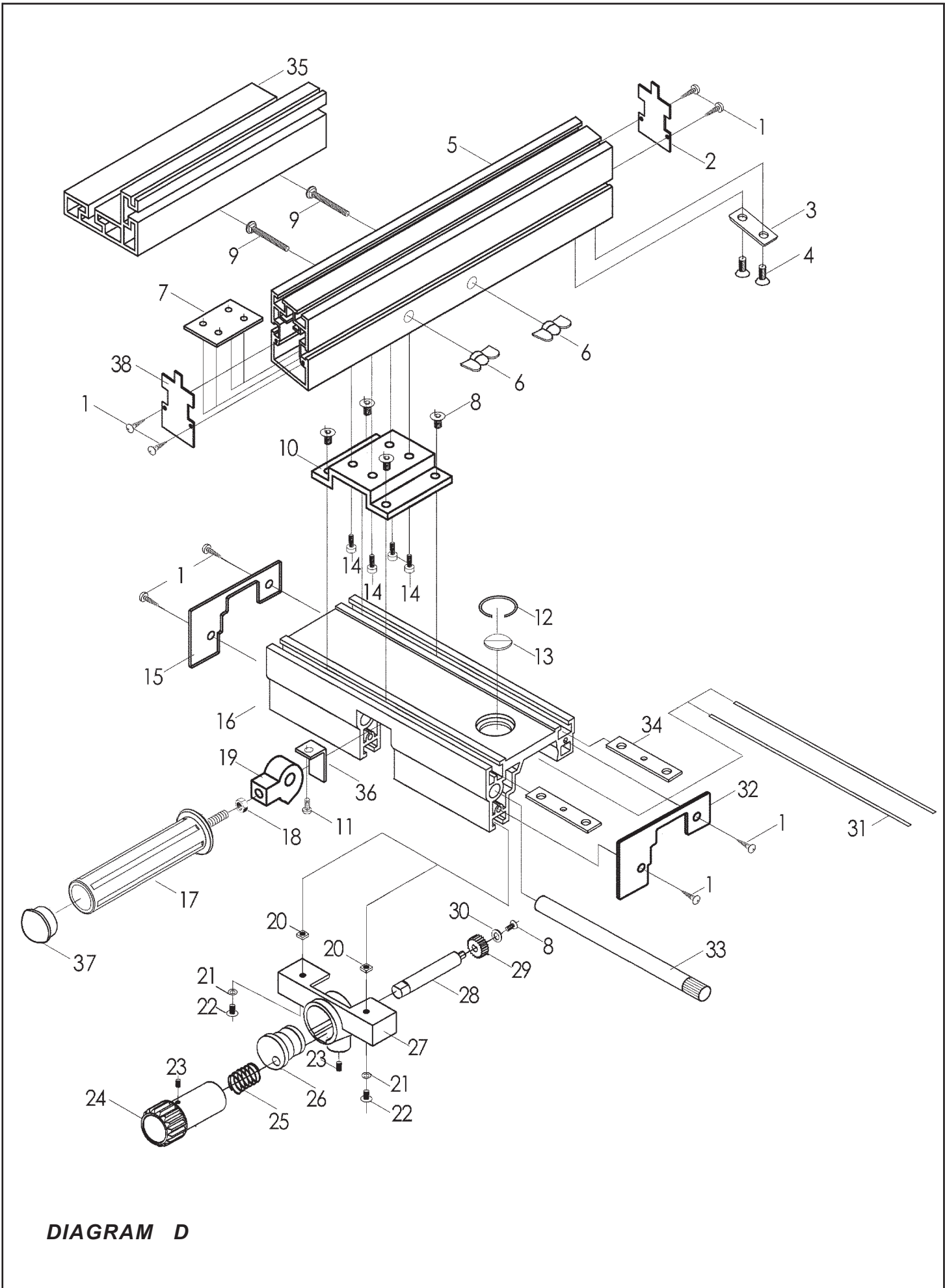
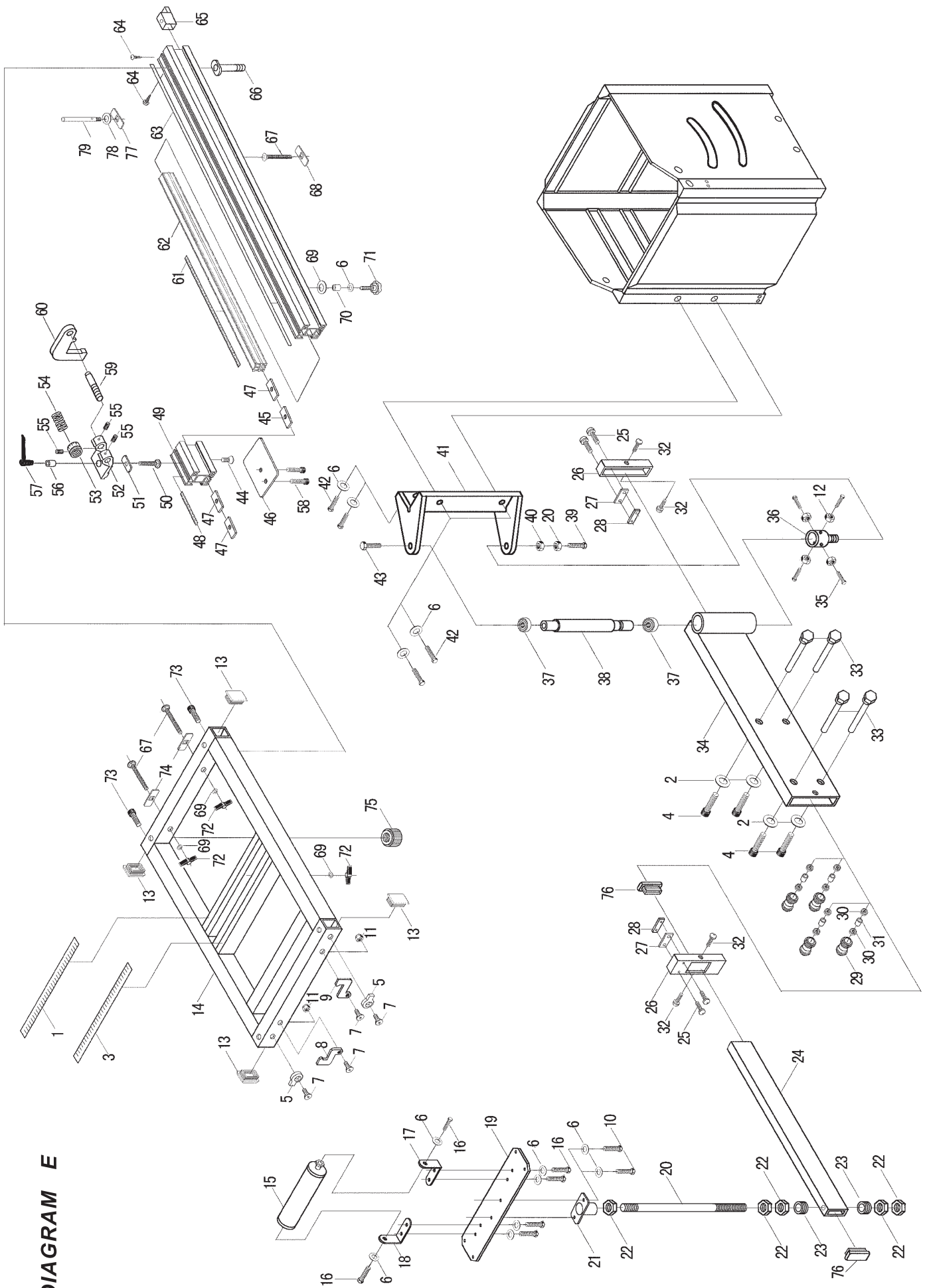


DIAGRAM D

DIAGRAM E



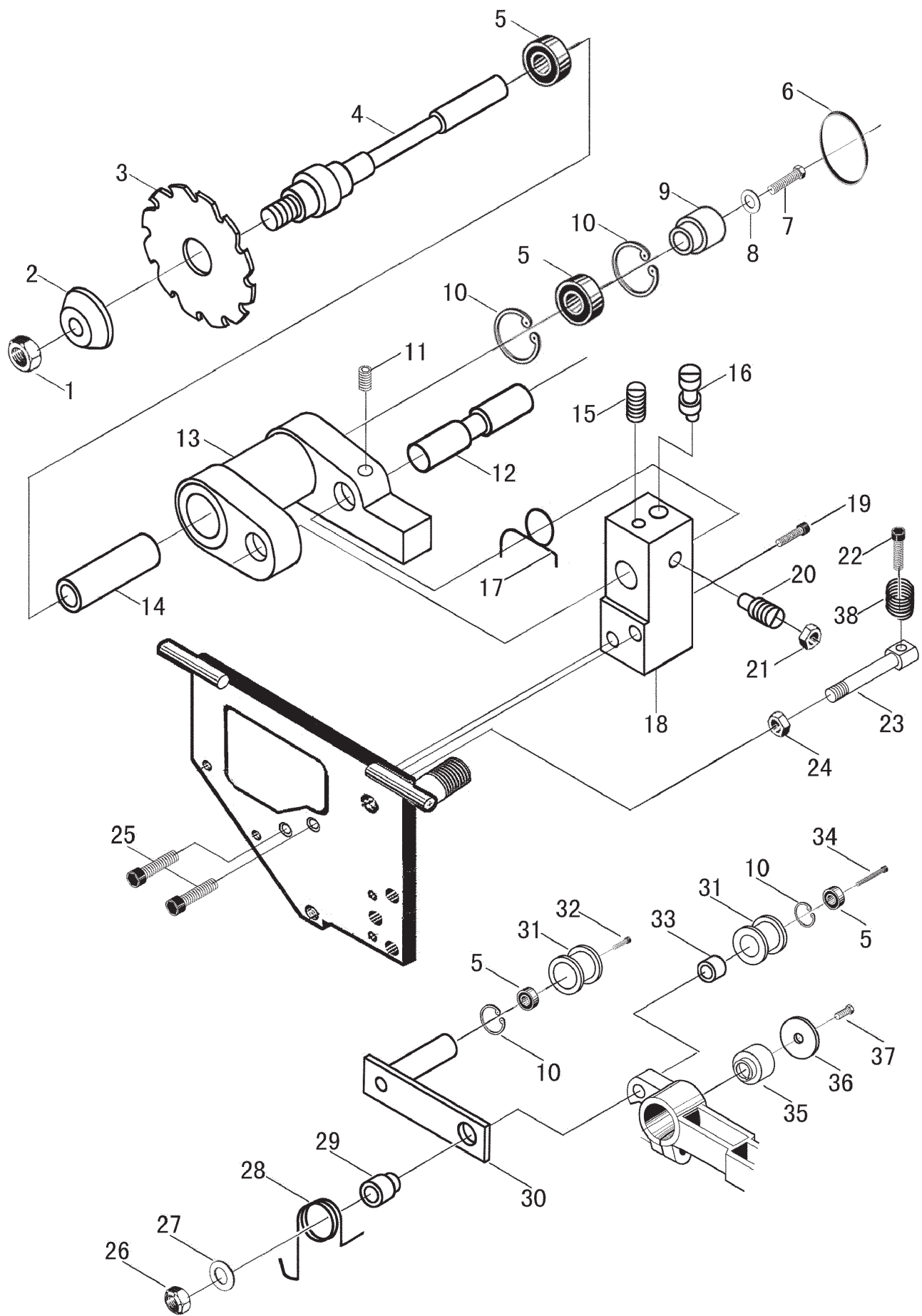


DIAGRAM F

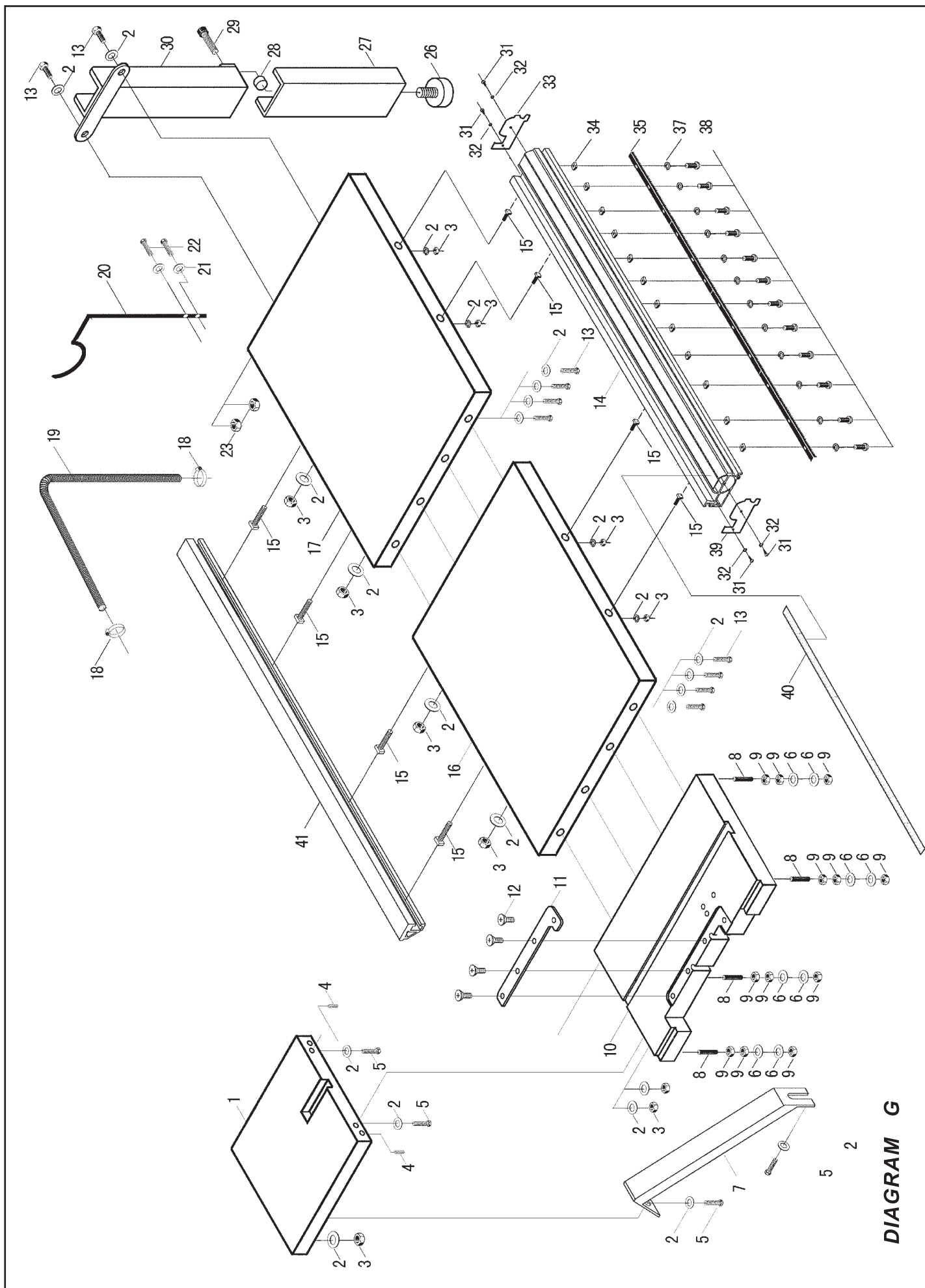


DIAGRAM G

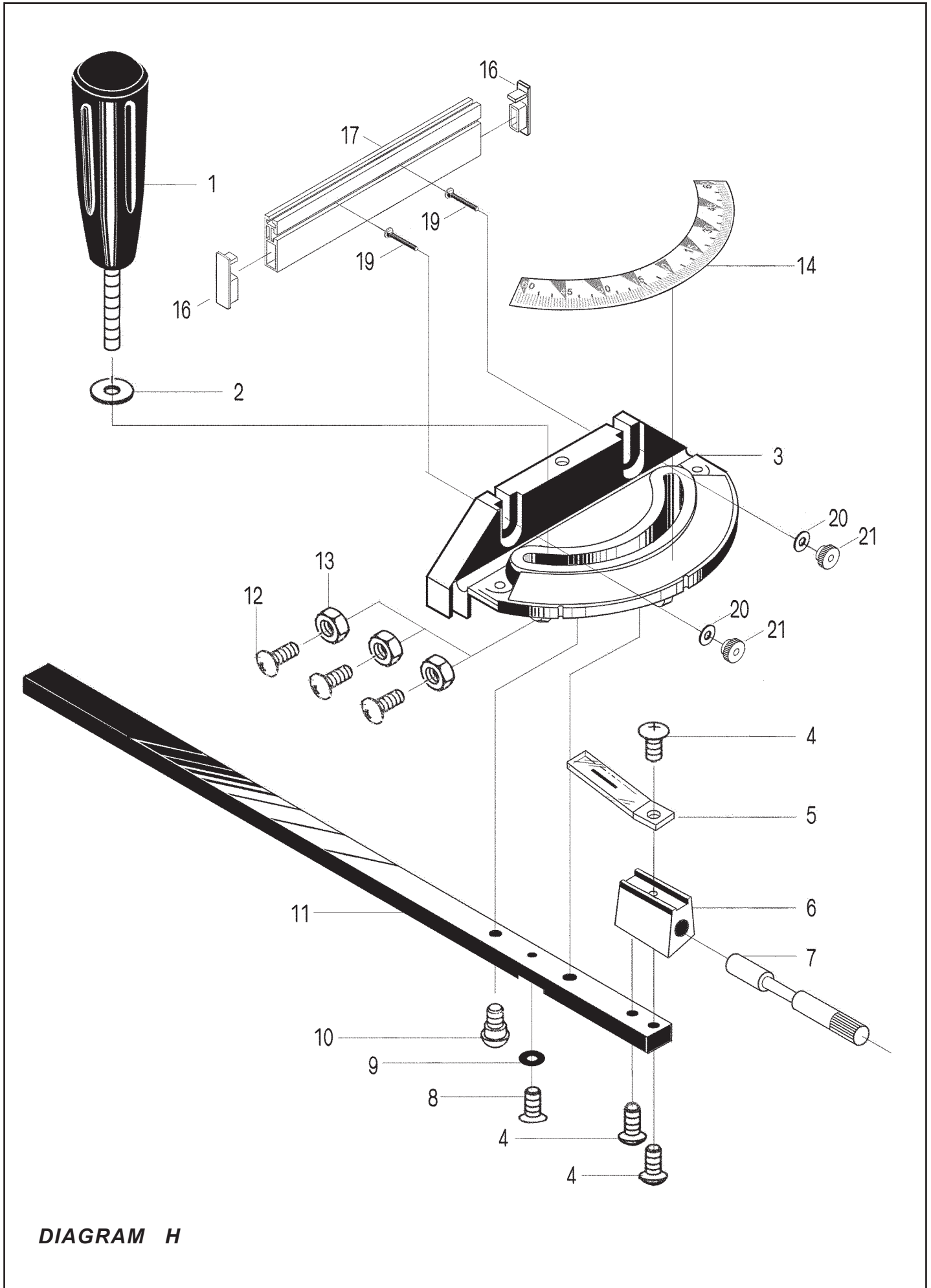
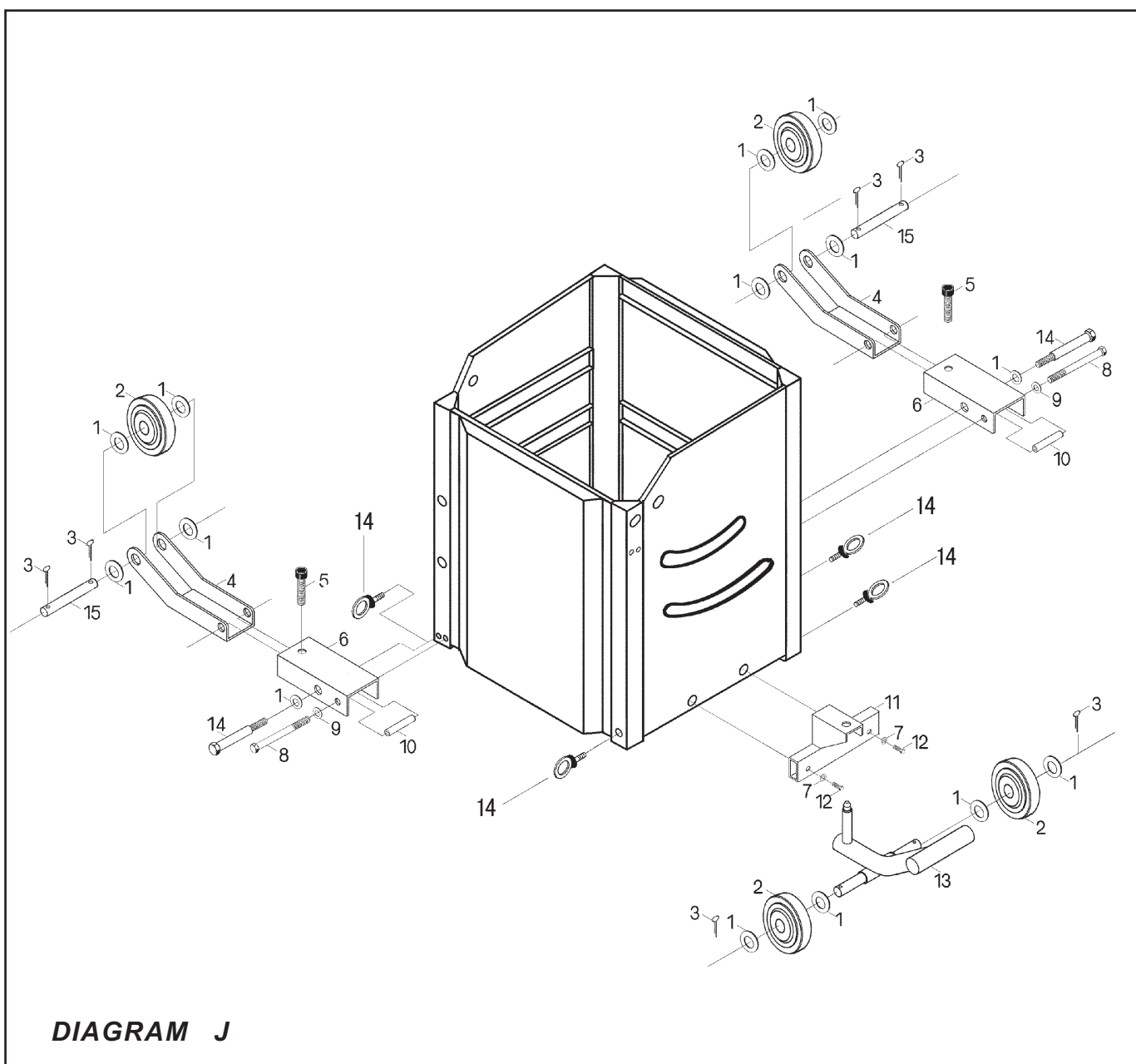


DIAGRAM H



Parts List Diagram J (optional)

No	Description	No	Description
J-1	Washer 16mm	J-9	Washer 12mm
J-2	Castor	J-10	Bushing bracket
J-3	Roll pin 4x30	J-11	Support, pull rod
J-4	Bracket castor	J-12	Hex screw M10x55
J-5	Allen screw M12x50	J-13	Pull rod
J-6	Bracket castor	J-14	Bolt, bracket
J-7	Washer 10mm	J-15	Shaft, castor
J-8	Hex screw M12x80	J-16	Lift ring